

DAWSONS-TECH[®]

OVER 35 YEARS OF EXPERIENCE



**CATALOGUE NO.
PPA-21**

**INSTRUMENTATION / CNG
PRECISION PIPE FITTINGS &
TUBE ADAPTERS**

www.dawsonstech.com

THE COMPANY :

DAWSONS-TECH® is an ISO 9001:2015 certified manufacturing company offers wide range of **Consistent, Reliable and Superior Quality** High Pressure Instrumentation / CNG / Hydrogen Products used in Vehicles, Fueling Equipments like CNG Cascades, CNG Dispensers, Booster Compressors, Online Compressors, Decompression Skid, LCV Filling Post, Meter Regulation Skids, Pressure Regulation Skids, etc.



dedicated team of employees in place. This facilitate us to design and manufacture our product range under stringent quality checks and measurements that ensures **"A TOTAL CUSTOMER SATISFACTIONS"**.

QUALITY :

DAWSONS-TECH® pursues not only performance of its products but also ensures **"TOTAL QUALITY CONTROL MANAGEMENT SYSTEMS IN ACCORDANCE WITH ISO 9001:2015"** which is achieved by alerting and educating each and every employee, the importance of quality and by implementing the quality control procedures at every stage of production to final inspection from incoming raw material to finish products.

MANUFACTURING :

DAWSONS-TECH® established its comprehensive state of art manufacturing and testing facility installing various CNC Turning Centre and CNC Turnmill Centre, Vertical Machining Centre, etc. with the highly motivated and

|  OUR CAPABILITIES |  CERTIFICATIONS |  BENEFITS |
|--|--|---|
| <ul style="list-style-type: none"> • Over 35 Years of Experience • Excellent Technical Knowledge • Latest Design Equipment's & Software • Modern Manufacturing Facilities • Highly Motivated Team of Employees • Excellent Inspection Facilities • Product Performance Testing Facilities | <ul style="list-style-type: none"> • ISO 9001-2015 • ISO 14001-2015 • ISO 45001-2018 • PED 2014/68/EU • ASTM F1387-19 • MSS SP-99-2016a • Helium Leak Test • Hydro Static Proof Test • Pneumatic Proof Test | <ul style="list-style-type: none"> • High Quality • Proven Design for Leak Free Connections • Effective Operations • High Efficiency • Prompt Reply • Maximum Flexibility • Maximum Safety in Operation • Substantial Cost Saving |







RESEARCH & DEVELOPMENT :

With our extensive experience, expertise and continues Research & Development with incorporation of advanced technology and high-tech cutting-edge machineries, **DAWSONS-TECH®** is committed to constant upgradation and expand its product range to meet the requirements of its customer to their entire satisfaction at every time.

CUSTOMER SATISFACTION :

We strive to achieve total customer satisfaction and continuously work to set higher goals to provide the reliable quality, timely delivery of our products and prompt services in the best interest of our customers with **Very Competitive Price**.

OUR MISSION

| | | | | | | | |
|---|---|---|---|---|--|--|---|
|  RESPONSIBILITY |  RELIABILITY |  ENVIRONMENTAL AWARENESS |  TECHNICAL EXPERTISE |  INNOVATIVE TECHNOLOGY |  DEVELOPMENT |  CUTTING EDGE SOLUTIONS |  TOTAL CUSTOMER SATISFACTION |
|---|---|---|---|---|--|--|---|

General Information :

DAWSONS-TECH Precision Threaded / Welded Pipe Fittings & Adaptors are generally used for small Pipe Lines. Socket Welded Joint Construction is a good choice wherever the benefit of high leakage integrity and structured strength are important.

Features / Benefits :

- Threaded Pipe Fittings are available with NPT, BSPT & SAE Thread End Connections.
- Welded Pipe Fittings are available with Socket & Butt Weld End Connections.
- Working Pressure calculated in accordance with Power Piping Code ANSI B31.1 and Refiner Piping Code ANSI B31.3.
- Straight Fittings are manufactured from Bar Stock and Shape Fittings are manufactured from close Grain Forgings.
- Available in Material SS316.



Straight Fittings are manufactured from high quality bar stock for strength.

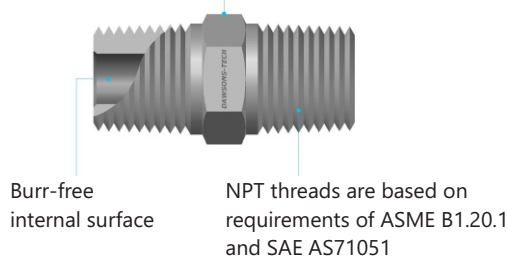

Shaped Fittings are manufactured from forgings

Marking indicates manufacturer and material of construction

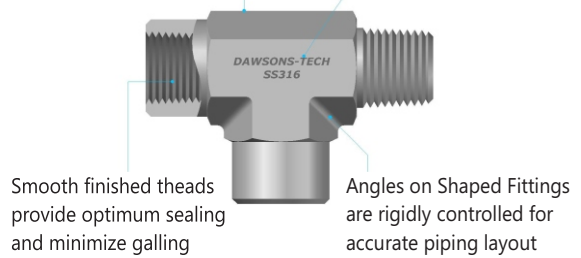

Male / Female Taper Pipe Threads are manufactured to maximum tolerances, ensures to have maximum thread engagement, robust, safe & secure connection.

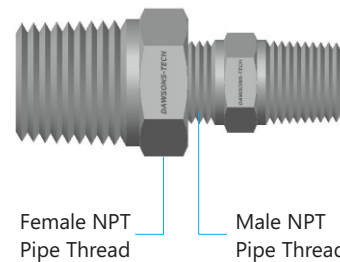

Heavy wall thickness and strength of material assures long life in desired service application

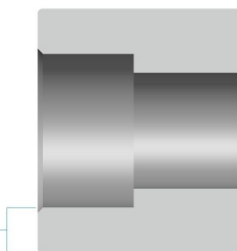

Precise machining of all surfaces assures excellent sealing contact



Slight taper in the Socket tube base ensure perfect assembly & alignment

Precise machining of socket assures proper tube fit

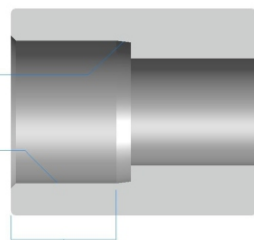

Socket depth designed to ensure proper tube support & consistent assembly

37.5° chamfer for proper weld Fillet

Precise Machining of outside Diameter matches exact pipe size

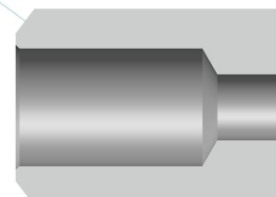

General Information :

Product Range & Operating Parameters :

Pressure Rating : UPTO 10,000 PSIG (689 Bar) depending on size at CWP.
Temperature Rating : UPTO 426°C.
End Connections - Fractional : 1/8" to 1" Pipe Thread / Pipe / Tube End.

Applications :

- Instrumentations
- General Services, etc.

Pipe Thread Information :

DAWSONS-TECH Pipe Fittings are available with NPT (National Pipe Thread), BSP / ISO (British Standard Pipe / International Standards Organization) and SAE/MS Straight Threads.

Tapered Threads :

| Specification | Type | Part No. or Suffix Designation | Sealing Method |
|---------------------|-------|--------------------------------|---|
| NPT ANSI B1.20.1 | M / F | N | Seal is on the Thread. Thread Sealant is required. |
| ISO 7/1 | M/F | RT | Seal is on the Thread. Thread Sealant is required. |
| BS 21 | M/F | | |
| JIS B0203 | M/F | | |
| DIN 2999 | Male | | |

Parallel Threads :

| Specification | Type | Part No. or Suffix Designation | Sealing Method |
|---|--------|--------------------------------|--|
| ISO 228 / 1+2 BS 2779 JIS B0202 | Male | RP | Metal To Metal sealing to DIN 3852, Form B. |
| ISO 228 / 1+2 BS 2779 JIS B0202 | Male | RS | Utilizes a sealing washer to provide sealing. Reference DIN 3852, Form B. |
| ISO 228 / 1+2 BS 27879 JIS B0202 | Female | RG | Sealing Form meets DIN 3852, Form Y. |
| BS2779 ISO 228 / 1+2 with Elastic Sealing | Male | ED | Sealing Form meets DIN 3852, Part 2, Form E. |
| SAE J514 | Male | SAE | Sealing with 'O' Ring |

PRECISION THREADED PIPE FITTINGS

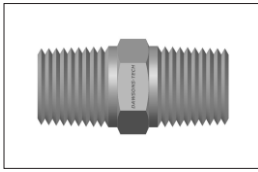

Hex Nipple
(NPT & BSPT)
Page No. 07

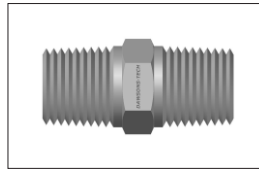

Hex Nipple
(NPT to BSPT)
Page No. 07

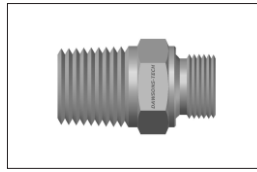

Hex Nipple
(NPT to BSP)
Page No. 08

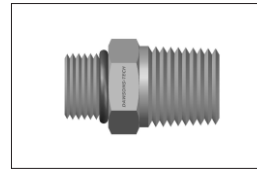

Hex Nipple
(SAE/MS to NPT)
Page No. 08

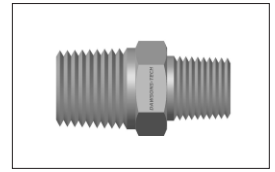

Hex Reducing Nipple
(NPT & BSPT)
Page No. 09

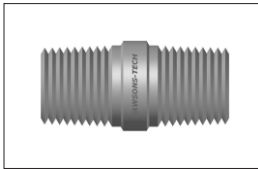

Close Nipple
(NPT)
Page No. 09

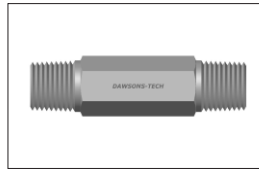

Hex Long Nipple
(NPT)
Page No. 10

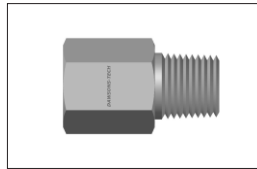

Adapter
(NPT & BSPT)
Page No. 10 & 11

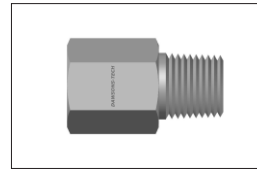

Adapter
(NPT to BSPT)
Page No. 11

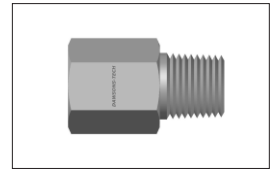

Adapter
(NPT to BSPT) & (BSPT to NPT)
Page No. 11



Adapter
(NPT to BSP)
Page No. 12

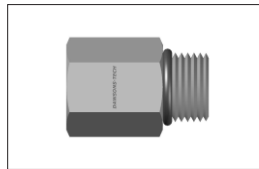

Adapter
(NPT to SAE/MS)
Page No. 12

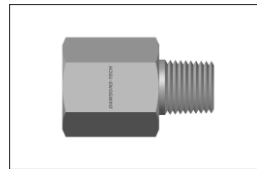

Reducing Adapter
(NPT & BSPT)
Page No. 13

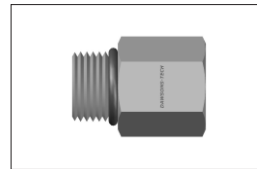

Reducing Adapter
(SAE/MS)
Page No. 13

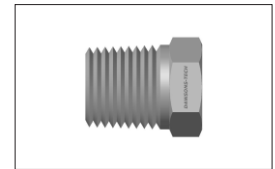

Reducing Bushing
(NPT & BSPT)
Page No. 14

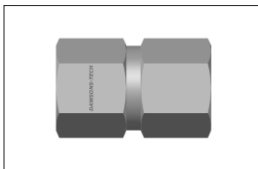

Hex Coupling
(NPT & BSPT)
Page No. 14 & 15

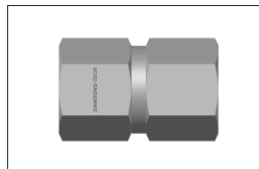

Hex Reducing Coupling
(NPT & BSPT)
Page No. 15

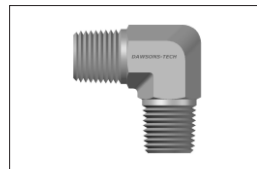

Male Elbow
(NPT)
Page No. 16

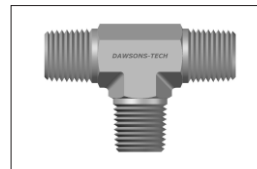

Male Tee
(NPT)
Page No. 16



Female Elbow
(NPT & BSPT)
Page No. 16 & 17

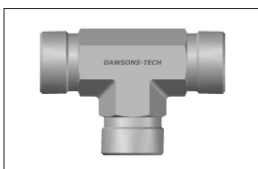

Female Tee
(NPT & BSPT)
Page No. 17

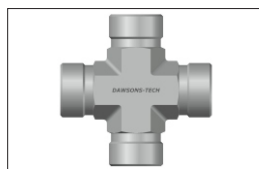

Female Cross
(NPT)
Page No. 18

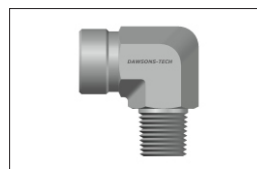

Street Elbow
(NPT)
Page No. 18

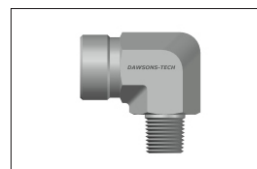

Reducing Street Elbow
(NPT)
Page No. 18

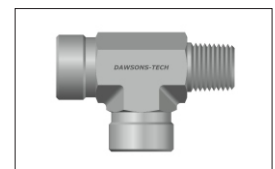

Street Tee
(NPT)
Page No. 19

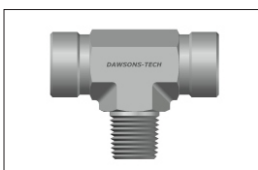

Branch Tee
(NPT)
Page No. 19

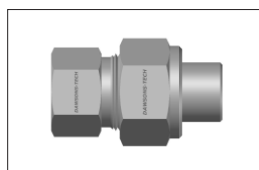

Union Ball Joint
(NPT)
Page No. 19

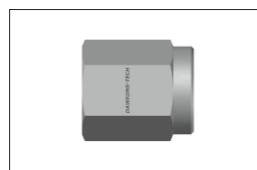

Pipe Cap
(NPT)
Page No. 20

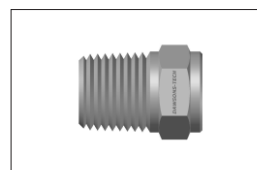

Pipe Plug
(NPT)
Page No. 20

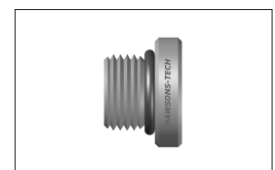

Hollow Hex Plug
(SAE/MS)
Page No. 20

PRECISION THREADED PIPE FITTINGS

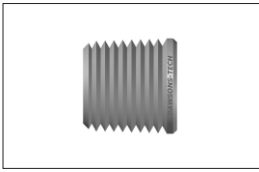

Hollow Hex Plug
(NPT & BSPT)
Page No . 21

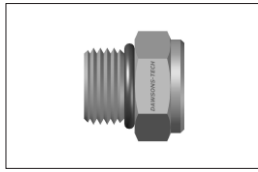

Hex Head Plug
(SAE/MS)
Page No. 21

SOCKET / BUTT WELD PIPE FITTINGS

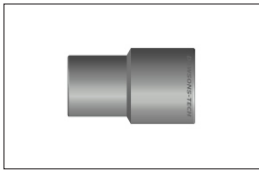

Reducing Adapter
Tube Butt Weld to Tube Socket Weld
Page No. 22

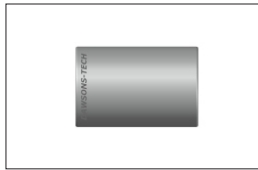

Union
Tube Socket Weld
Page No. 22



Union Elbow
Tube Socket Weld
Page No. 22

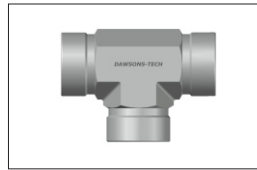

Union Tee
Tube Socket Weld
Page No. 23



Union Cross
Tube Socket Weld
Page No. 23

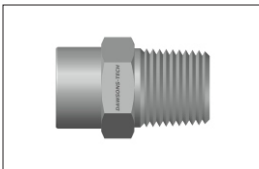

Male Connector
Tube Socket Weld
Page No. 23



Male Elbow
Tube Socket Weld
Page No. 24

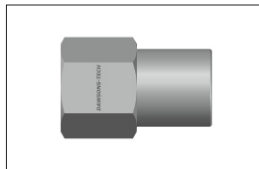

Female Connector
Tube Socket Weld
Page No. 24



Female Elbow
Tube Socket Weld
Page No. 24



Reducing Adapter
Pipe Butt Weld to Tube Socket Weld
Page No . 25

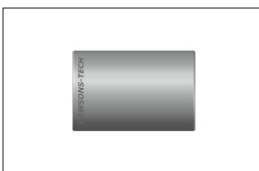

Union
Pipe Socket Weld
Page No. 25

TUBE ADAPTERS

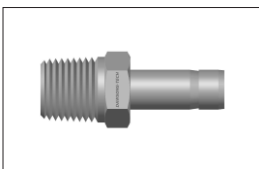

Male Adapter
(NPT)
Page No. 26

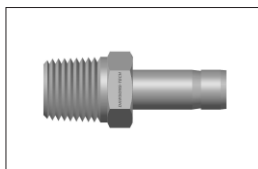

Male Adapter
(BSPT)
Page No. 26

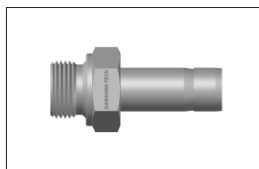

Male Adapter
(BSP)
Page No. 27

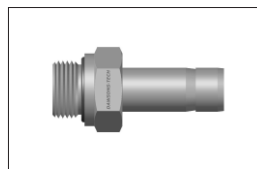

Male Adapter
(BSP)
Page No. 27

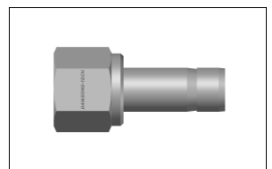

Female Adapter
(NPT)
Page No . 28

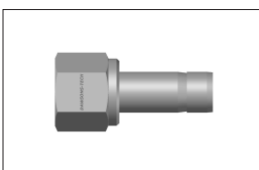

Female Adapter
(BSPT)
Page No. 28

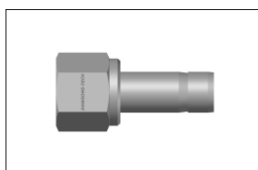

Female Adapter
(BSP)
Page No. 29

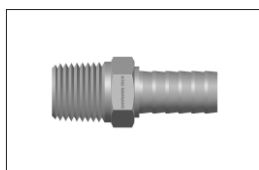

Male Hose Adapter
(NPT)
Page No. 29

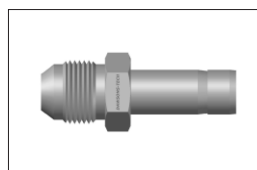

AN Male Adapter

Page No. 29

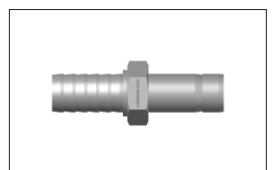

Tube To Hose Adapter

Page No. 30

Hex Nipple (Male NPT Threads)

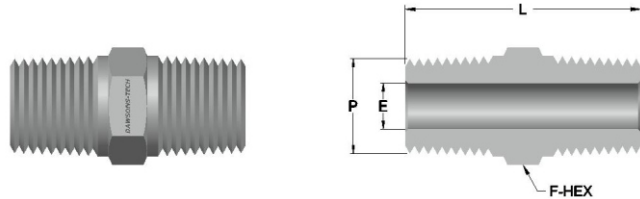

STANDARD CONFIGURATION DIMENSIONS

| NPT Thread Size | Dimensions in mm | | F-Hex (Inch) | Pressure Rating PSIG (Bar) | Dawsons-Tech Part No. |
|-----------------|------------------|------|--------------|----------------------------|-----------------------|
| | P | E | | | |
| 1/8 | 4.8 | 27.0 | 7/16 | 9100 (620) | HN-2N |
| 1/4 | 7.1 | 37.0 | 9/16 | 7500 (510) | HN-4N |
| 3/8 | 9.6 | 37.0 | 11/16 | 7200 (490) | HN-6N |
| 1/2 | 11.9 | 48.0 | 7/8 | 6600 (450) | HN-8N |
| 3/4 | 15.7 | 50.0 | 1-1/16 | 6400 (435) | HN-12N |
| 1 | 22.4 | 59.0 | 1-3/8 | 4600 (313) | HN-16N |

Dimensions are for reference only and are subject to change.

Hex Nipple (Male ISO Tapered (BSPT) Threads)

| BSPT Thread Size | Dimensions in mm | | F-Hex (Inch) | Pressure Rating PSIG (Bar) | Dawsons-Tech Part No. |
|------------------|------------------|------|--------------|----------------------------|-----------------------|
| | P | E | | | |
| 1/8 | 4.8 | 27.0 | 7/16 | 9100 (620) | HN-2RT |
| 1/4 | 7.1 | 37.0 | 9/16 | 7500 (510) | HN-4RT |
| 3/8 | 9.6 | 37.0 | 11/16 | 7200 (490) | HN-6RT |
| 1/2 | 11.9 | 48.0 | 7/8 | 6600 (450) | HN-8RT |
| 3/4 | 15.7 | 50.0 | 1-1/16 | 6400 (435) | HN-12RT |
| 1 | 22.4 | 59.0 | 1-3/8 | 4600 (313) | HN-16RT |

Dimensions are for reference only and are subject to change.

Hex Nipple (Male NPT to Male ISO Tapered (BSPT) Threads)

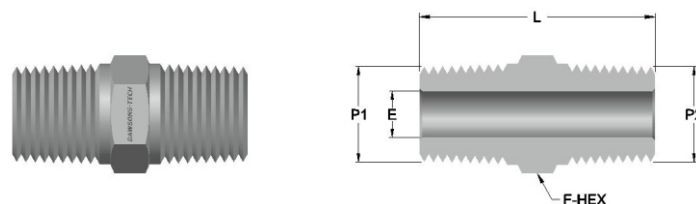

STANDARD CONFIGURATION DIMENSIONS

| NPT Thread Size | BSPT Thread Size | Dimensions in mm | | F-Hex (Inch) | Pressure Rating PSIG (Bar) | Dawsons-Tech Part No. |
|-----------------|------------------|------------------|------|--------------|----------------------------|-----------------------|
| | | E | L | | | |
| 1/8 | 1/8 | 4.8 | 27.0 | 7/16 | 9100 (620) | HN-2N-2RT |
| 1/4 | 1/4 | 7.1 | 37.0 | 9/16 | 7500 (510) | HN-4N-4RT |
| 3/8 | 3/8 | 9.6 | 37.0 | 11/16 | 7200 (490) | HN-6N-6RT |
| 1/2 | 1/2 | 11.9 | 48.0 | 7/8 | 6600 (450) | HN-8N-8RT |
| 3/4 | 3/4 | 15.7 | 50.0 | 1-1/16 | 6400 (435) | HN-12N-12RT |
| 1 | 1 | 22.4 | 59.0 | 1-3/8 | 4600 (313) | HN-16N-16RT |

Dimensions are for reference only and are subject to change.

Hex Nipple (Male NPT to Male ISO (BSP) Parallel Threads)

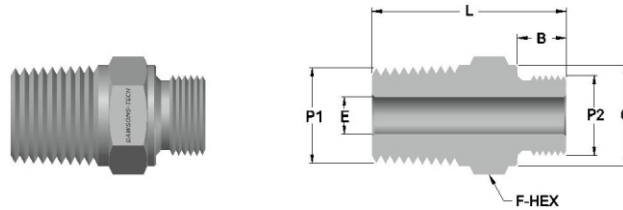

STANDARD CONFIGURATION DIMENSIONS

| NPT Thread Size | BSP Thread Size | Dimensions in mm | | | | F-Hex (Inch) | Pressure Rating PSIG (Bar) | Dawsons-Tech Part No. |
|-----------------|-----------------|------------------|------|------|------|--------------|----------------------------|-----------------------|
| | | P1 | P2 | B | C | | | |
| 1/8 | 1/8 | 7.1 | 13.7 | 4.1 | 27.2 | 9/16 | 9100 (620) | HN-2N-2RS |
| 1/4 | 1/4 | 11.2 | 18.0 | 5.8 | 36.6 | 3/4 | 7500 (510) | HN-4N-4RS |
| 3/8 | 3/8 | 11.2 | 21.6 | 7.9 | 37.3 | 7/8 | 7200 (490) | HN-6N-6RS |
| 1/2 | 1/2 | 14.2 | 25.9 | 11.9 | 45.2 | 1-1/16 | 6600 (450) | HN-8N-8RS |
| 3/4 | 3/4 | 15.7 | 31.5 | 15.7 | 49.5 | 1-1/4 | 6400 (435) | HN-12N-12RS |
| 1 | 1 | 18.3 | 38.9 | 19.8 | 57.4 | 1-5/8 | 4600 (313) | HN-16N-16RS |

Dimensions are for reference only and are subject to change.

Hex Nipple (Male SAE/MS Straight Thread to Male NPT Threads)

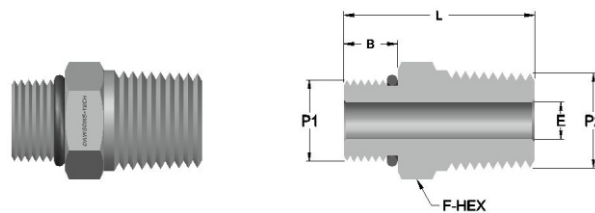

STANDARD CONFIGURATION DIMENSIONS

| SAE/MS Thread Size | NPT Thread Size | Dimensions in mm | | | F-Hex (Inch) | Uniform 'O' Ring Size | Pressure Rating PSIG (Bar) | Dawsons-Tech Part No. |
|--------------------|-----------------|------------------|------|------|--------------|-----------------------|----------------------------|-----------------------|
| | | B | E | L | | | | |
| 7/16 - 20 | 1/4 | 9.1 | 5.1 | 30.5 | 9/16 | -907 | 4500 (306) | HN-7SAE-4N |
| 9/16 - 18 | 3/8 | 9.1 | 7.1 | 32.0 | 11/16 | -906 | 4500 (306) | HN-9SAE-6N |
| 3/4 - 16 | 1/2 | 11.2 | 10.7 | 38.9 | 7/8 | -908 | 4500 (306) | HN-12SAE-8N |
| 1-1/16 - 12 | 3/4 | 15.0 | 15.7 | 44.4 | 1-1/4 | -912 | 3600 (245) | HN-17SAE-12N |
| 1-5/16 - 12 | 1 | 15.0 | 22.4 | 50.8 | 1-1/2 | -916 | 2900 (198) | HN-21SAE-16N |

Dimensions are for reference only and are subject to change.

Hex Reducing Nipple (Male NPT Threads)

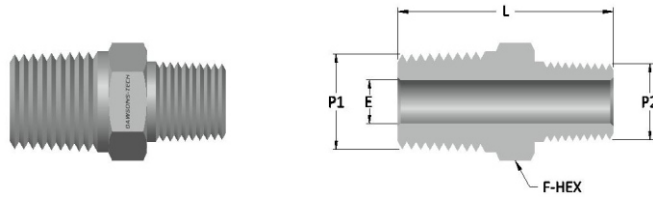

STANDARD CONFIGURATION DIMENSIONS

| NPT Thread Size | Reduced NPT Thread Size | Dimensions in mm | | F-Hex (Inch) | Pressure Rating PSIG (Bar) | Dawsons-Tech Part No. |
|-----------------|-------------------------|------------------|------|--------------|----------------------------|-----------------------|
| | | E | L | | | |
| P1 | P2 | | | | | |
| 1/4 | 1/8 | 4.8 | 31.0 | 9/16 | 7500 (510) | HRN-4N-2N |
| 3/8 | 1/8 | 4.8 | 31.8 | 11/16 | 7200 (490) | HRN-6N-2N |
| 3/8 | 1/4 | 7.1 | 36.3 | 11/16 | 7200 (490) | HRN-6N-4N |
| 1/2 | 1/8 | 4.8 | 37.3 | 7/8 | 6600 (450) | HRN-8N-2N |
| 1/2 | 1/4 | 7.1 | 41.9 | 7/8 | 6600 (450) | HRN-8N-4N |
| 1/2 | 3/8 | 9.6 | 41.9 | 7/8 | 6600 (450) | HRN-8N-6N |
| 3/4 | 1/4 | 7.1 | 41.9 | 1-1/16 | 6400 (435) | HRN-12N-4N |
| 3/4 | 3/8 | 9.6 | 41.9 | 1-1/16 | 6400 (435) | HRN-12N-6N |
| 3/4 | 1/2 | 11.9 | 46.7 | 1-1/16 | 6400 (435) | HRN-12N-8N |
| 1 | 1/4 | 7.1 | 49.3 | 1-3/8 | 4600 (313) | HRN-16N-4N |
| 1 | 3/8 | 9.6 | 49.3 | 1-3/8 | 4600 (313) | HRN-16N-6N |
| 1 | 1/2 | 11.9 | 54.1 | 1-3/8 | 4600 (313) | HRN-16N-8N |
| 1 | 3/4 | 15.7 | 54.1 | 1-3/8 | 4600 (313) | HRN-16N-12N |

Dimensions are for reference only and are subject to change.

Hex Reducing Nipple (Male ISO Tapered (BSPT) Threads)

| BSPT Thread Size | Reduced BSPT Thread Size | Dimensions in mm | | F-Hex (Inch) | Pressure Rating PSIG (Bar) | Dawsons-Tech Part No. |
|------------------|--------------------------|------------------|------|--------------|----------------------------|-----------------------|
| | | E | L | | | |
| P1 | P2 | | | | | |
| 3/8 | 1/4 | 7.1 | 36.3 | 11/16 | 7200 (490) | HRN-6RT-4RT |
| 1/2 | 1/8 | 4.8 | 37.3 | 7/8 | 6600 (450) | HRN-8RT-2RT |
| 1/2 | 3/8 | 9.6 | 41.9 | 7/8 | 6600 (450) | HRN-8RT-6RT |

Dimensions are for reference only and are subject to change.

Close Nipple (Male NPT Threads)

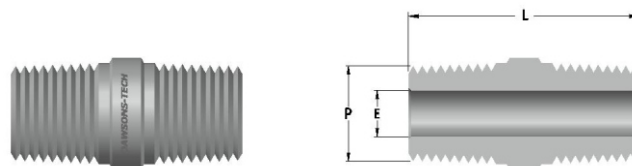

STANDARD CONFIGURATION DIMENSIONS

| NPT Thread Size | Dimensions in mm | | Pressure Rating PSIG (Bar) | Dawsons-Tech Part No. |
|-----------------|------------------|------|----------------------------|-----------------------|
| | E | L | | |
| P | | | | |
| 1/8 | 4.8 | 19.1 | 9100 (620) | CN-2N |
| 1/4 | 7.1 | 28.4 | 7500 (510) | CN-4N |
| 3/8 | 9.6 | 28.4 | 7200 (490) | CN-6N |
| 1/2 | 11.9 | 38.1 | 6600 (450) | CN-8N |
| 3/4 | 15.7 | 38.1 | 6400 (435) | CN-12N |
| 1 | 22.4 | 47.8 | 4600 (313) | CN-16N |

Dimensions are for reference only and are subject to change.

Hex Long Nipple (Male NPT Threads)

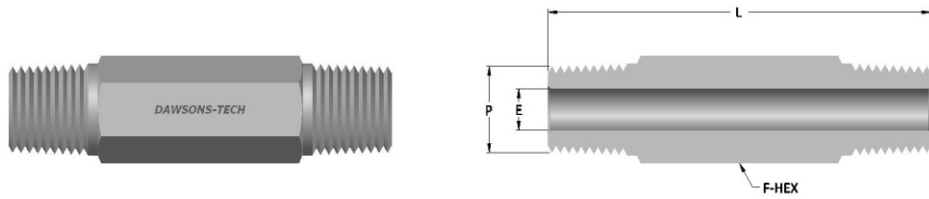

STANDARD CONFIGURATION DIMENSIONS

| NPT Thread Size | Dimensions in mm (Inch) | | F-Hex (Inch) | Pressure Rating PSIG (Bar) | Dawsons-Tech Part No. |
|-----------------|-------------------------|-------------|--------------|----------------------------|-----------------------|
| | P | E | | | |
| 1/8 | 4.8 | 38.1 (1.5) | 7/16 | 9100 (620) | HLN-2N-24 |
| 1/8 | 4.8 | 50.8 (2.0) | 7/16 | 9100 (620) | HLN-2N-32 |
| 1/8 | 4.8 | 63.5 (2.5) | 7/16 | 9100 (620) | HLN-2N-40 |
| 1/8 | 4.8 | 76.2 (3.0) | 7/16 | 9100 (620) | HLN-2N-48 |
| 1/4 | 7.1 | 38.1 (1.5) | 9/16 | 7500 (510) | HLN-4N-24 |
| 1/4 | 7.1 | 50.8 (2.0) | 9/16 | 7500 (510) | HLN-4N-32 |
| 1/4 | 7.1 | 63.5 (2.5) | 9/16 | 7500 (510) | HLN-4N-40 |
| 1/4 | 7.1 | 76.2 (3.0) | 9/16 | 7500 (510) | HLN-4N-48 |
| 1/4 | 7.1 | 101.6 (4.0) | 9/16 | 7500 (510) | HLN-4N-64 |
| 3/8 | 9.6 | 38.1 (1.5) | 11/16 | 7200 (490) | HLN-6N-24 |
| 3/8 | 9.6 | 50.8 (2.0) | 11/16 | 7200 (490) | HLN-6N-32 |
| 3/8 | 9.6 | 63.5 (2.5) | 11/16 | 7200 (490) | HLN-6N-40 |
| 3/8 | 9.6 | 76.2 (3.0) | 11/16 | 7200 (490) | HLN-6N-48 |
| 3/8 | 9.6 | 101.6 (4.0) | 11/16 | 7200 (490) | HLN-6N-64 |
| 1/2 | 11.9 | 50.8 (2.0) | 7/8 | 6600 (450) | HLN-8N-32 |
| 1/2 | 11.9 | 76.2 (3.0) | 7/8 | 6600 (450) | HLN-8N-48 |
| 1/2 | 11.9 | 101.6 (4.0) | 7/8 | 6600 (450) | HLN-8N-64 |
| 1/2 | 11.9 | 152.4 (6.0) | 7/8 | 6600 (450) | HLN-8N-96 |
| 3/4 | 15.7 | 50.8 (2.0) | 1-1/16 | 6400 (435) | HLN-12N-32 |
| 3/4 | 15.7 | 76.2 (3.0) | 1-1/16 | 6400 (435) | HLN-12N-48 |
| 3/4 | 15.7 | 101.6 (4.0) | 1-1/16 | 6400 (435) | HLN-12N-64 |
| 1 | 22.4 | 76.2 (3.0) | 1-3/8 | 4600 (313) | HLN-16N-48 |
| 1 | 22.4 | 101.6 (4.0) | 1-3/8 | 4600 (313) | HLN-16N-64 |

Dimensions are for reference only and are subject to change.

Adapter (Female to Male NPT Threads)

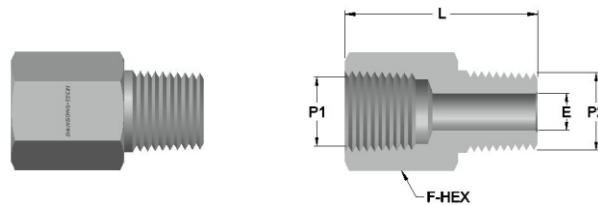

STANDARD CONFIGURATION DIMENSIONS

| Female NPT Thread Size | Male NPT Thread Size | Dimensions in mm | | F-Hex (Inch) | Pressure Rating PSIG (Bar) | Dawsons-Tech Part No. |
|------------------------|----------------------|------------------|------|--------------|----------------------------|-----------------------|
| | | P1 | P2 | | | |
| 1/8 | 1/8 | 4.8 | 27.9 | 9/16 | 6400 (435) | A-2N |
| 1/4 | 1/4 | 7.1 | 35.6 | 3/4 | 6600 (450) | A-4N |
| 3/8 | 3/8 | 9.6 | 38.4 | 7/8 | 5300 (360) | A-6N |
| 1/2 | 1/2 | 11.9 | 49.3 | 1-1/16 | 5200 (354) | A-8N |
| 3/4 | 3/4 | 15.7 | 51.3 | 1-1/4 | 4300 (292) | A-12N |
| 1 | 1 | 22.1 | 57.6 | 1-5/8 | 4500 (306) | A-16N |

Dimensions are for reference only and are subject to change.

Adapter (Female to Male BSPT Threads)

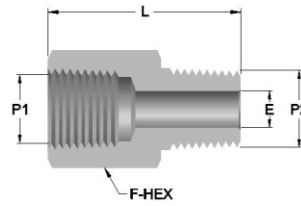
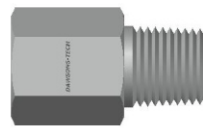

STANDARD CONFIGURATION DIMENSIONS

| Female BSPT Thread Size | Male BSPT Thread Size | Dimensions in mm | | F-Hex (Inch) | Pressure Rating PSIG (Bar) | Dawsons-Tech Part No. |
|-------------------------|-----------------------|------------------|------|--------------|----------------------------|-----------------------|
| | | P1 | P2 | | | |
| 1/8 | 1/8 | 4.8 | 27.9 | 9/16 | 6400 (435) | A-2RT |
| 1/4 | 1/4 | 7.1 | 35.6 | 3/4 | 6600 (450) | A-4RT |
| 3/8 | 3/8 | 9.6 | 38.4 | 7/8 | 5300 (360) | A-6RT |
| 1/2 | 1/2 | 11.9 | 49.3 | 1-1/16 | 5200 (354) | A-8RT |

Dimensions are for reference only and are subject to change.

Adapter (Female NPT to Male ISO Tapered (BSPT) Threads)

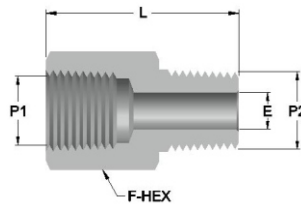
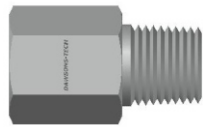

STANDARD CONFIGURATION DIMENSIONS

| Female NPT Thread Size | Male BSPT Thread Size | Dimensions in mm | | F-Hex (Inch) | Pressure Rating PSIG (Bar) | Dawsons-Tech Part No. |
|------------------------|-----------------------|------------------|------|--------------|----------------------------|-----------------------|
| | | P1 | P2 | | | |
| 1/8 | 1/8 | 4.8 | 27.7 | 9/16 | 6100 (415) | A-2N-2RT |
| 1/4 | 1/4 | 7.1 | 36.1 | 3/4 | 6200 (422) | A-4N-4RT |
| 3/8 | 3/8 | 9.6 | 38.1 | 7/8 | 5000 (340) | A-6N-6RT |
| 1/2 | 1/2 | 11.9 | 49.3 | 1-1/16 | 4600 (315) | A-8N-8RT |
| 3/4 | 3/4 | 15.7 | 51.3 | 1-1/4 | 4300 (292) | A-12N-12R |
| 1 | 1 | 22.4 | 58.4 | 1-5/8 | 4100 (280) | A-16N-16RT |

Dimensions are for reference only and are subject to change.

Adapter (Female ISO Tapered (BSPT) to Male NPT Threads)

| Female BSPT Thread Size | Male NPT Thread Size | Dimensions in mm | | F-Hex (Inch) | Pressure Rating PSIG (Bar) | Dawsons-Tech Part No. |
|-------------------------|----------------------|------------------|------|--------------|----------------------------|-----------------------|
| | | P1 | P2 | | | |
| 1/4 | 1/4 | 7.1 | 36.3 | 3/4 | 6200 (422) | A-4RT-4N |
| 3/8 | 3/8 | 9.6 | 38.4 | 7/8 | 5000 (340) | A-6RT-6N |
| 1/2 | 1/2 | 11.9 | 49.8 | 1-1/16 | 4600 (315) | A-8RT-8N |

Dimensions are for reference only and are subject to change.

Adapter (Female NPT to Male ISO Parallel (BSP) Threads)

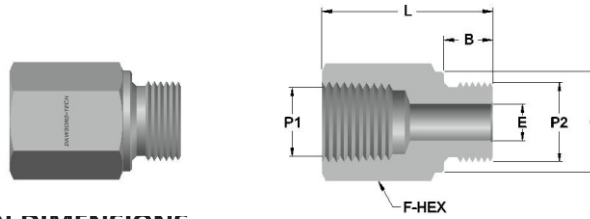

STANDARD CONFIGURATION DIMENSIONS

| Female NPT Thread Size | Male BSP Thread Size | Dimensions in mm | | | | F-Hex (Inch) | Pressure Rating PSIG (Bar) | Dawsons-Tech Part No. |
|------------------------|----------------------|------------------|------|------|------|--------------|----------------------------|-----------------------|
| | | P1 | P2 | B | C | | | |
| 1/8 | 1/8 | 7.1 | 13.7 | 4.1 | 25.1 | 9/16 | 6100 (415) | A-2N-2RS |
| 1/4 | 1/4 | 11.2 | 18.0 | 5.8 | 33.5 | 3/4 | 6200 (422) | A-4N-4RS |
| 3/8 | 3/8 | 11.2 | 21.6 | 7.9 | 35.8 | 7/8 | 5000 (340) | A-6N-6RS |
| 1/2 | 1/2 | 14.2 | 25.9 | 11.9 | 44.2 | 1-1/16 | 4600 (315) | A-8N-8RS |
| 3/4 | 3/4 | 15.7 | 31.5 | 15.7 | 48.0 | 1-1/4 | 4300 (292) | A-12N-12RS |
| 1 | 1 | 18.3 | 38.9 | 19.8 | 53.3 | 1-5/8 | 4100 (280) | A-16N-16RS |

Dimensions are for reference only and are subject to change.

Adapter (Female NPT to Male SAE/MS Straight Threads)

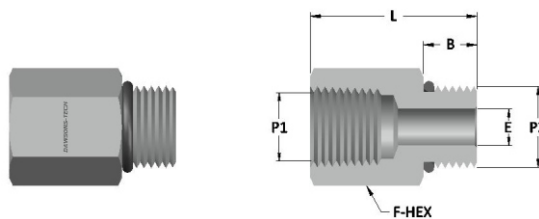

STANDARD CONFIGURATION DIMENSIONS

| NPT Thread Size | Male SAE / MS Thread Size | Dimensions in mm | | | F-Hex (Inch) | Uniform 'O' Ring Size | Pressure Rating PSIG (Bar) | Dawsons-Tech Part No. |
|-----------------|---------------------------|------------------|------|------|--------------|-----------------------|----------------------------|-----------------------|
| | | B | E | L | | | | |
| 1/4 | 7/16 - 20 | 9.1 | 5.1 | 33.5 | 3/4 | -904 | 4500 (306) | A-4N-7SAE |
| 3/8 | 9/16 - 18 | 9.9 | 7.1 | 35.3 | 7/8 | -906 | 4500 (306) | A-6N-9SAE |
| 1/2 | 3/4 - 16 | 11.2 | 10.6 | 44.7 | 1-1/16 | -908 | 4500 (306) | A-8N-12SAE |
| 3/4 | 1-1/16 - 12 | 15.0 | 16.7 | 50.5 | 1-1/4 | -912 | 3600 (245) | A-12N-17SAE |
| 1 | 1-5/16 - 12 | 15.0 | 22.3 | 53.8 | 1-5/8 | -916 | 2900 (198) | A-16N-21SAE |

Dimensions are for reference only and are subject to change.

Reducing Adapter (Female to Male NPT Threads)

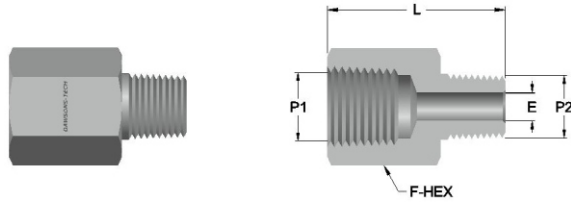

STANDARD CONFIGURATION DIMENSIONS

| Female NPT Thread Size | Reduced Male NPT Thread Size | Dimensions in mm | | F-Hex (Inch) | Pressure Rating PSIG (Bar) | Dawsons-Tech Part No. |
|------------------------|------------------------------|------------------|------|--------------|----------------------------|-----------------------|
| | | P1 | P2 | | | |
| 1/4 | 1/8 | 4.8 | 32.0 | 3/4 | 6600 (450) | RA-4N-2N |
| 3/8 | 1/8 | 4.8 | 33.8 | 7/8 | 5300 (360) | RA-6N-2N |
| 3/8 | 1/4 | 7.1 | 38.1 | 7/8 | 5300 (360) | RA-6N-4N |
| 1/2 | 1/8 | 4.8 | 40.1 | 1-1/16 | 5200 (354) | RA-8N-2N |
| 1/2 | 1/4 | 7.1 | 44.7 | 1-1/16 | 5200 (354) | RA-8N-4N |
| 1/2 | 3/8 | 9.6 | 44.4 | 1-1/16 | 5200 (354) | RA-8N-6N |
| 3/4 | 1/4 | 7.1 | 47.0 | 1-1/4 | 4300 (292) | RA-12N-4N |
| 3/4 | 3/8 | 9.6 | 46.2 | 1-1/4 | 4300 (292) | RA-12N-6N |
| 3/4 | 1/2 | 11.9 | 51.3 | 1-1/4 | 4300 (292) | RA-12N-8N |
| 1 | 1/4 | 7.1 | 49.8 | 1-5/8 | 4500 (306) | RA-16N-4N |
| 1 | 1/2 | 11.9 | 54.9 | 1-5/8 | 4500 (306) | RA-16N-8N |
| 1 | 3/4 | 15.7 | 55.1 | 1-5/8 | 4500 (306) | RA-16N-12N |

Dimensions are for reference only and are subject to change.

Reducing Adapter (Female to Male ISO Tapered (BSPT) Threads)

| Female BSPT Thread Size | Reduced Male BSPT Thread Size | Dimensions in mm | | F-Hex (Inch) | Pressure Rating PSIG (Bar) | Dawsons-Tech Part No. |
|-------------------------|-------------------------------|------------------|------|--------------|----------------------------|-----------------------|
| | | P1 | P2 | | | |
| 1/4 | 1/8 | 4.8 | 32.0 | 13/16 | 6600 (450) | RA-4RT-2RT |
| 3/8 | 1/4 | 7.1 | 38.1 | 7/8 | 5300 (360) | RA-6RT-4RT |
| 1/2 | 1/4 | 7.1 | 44.7 | 1-1/16 | 5200 (354) | RA-8RT-4RT |
| 1/2 | 3/8 | 9.6 | 44.4 | 1-1/16 | 5200 (354) | RA-8RT-6RT |

Dimensions are for reference only and are subject to change.

Reducing Adapter (Male SAE/MS to Female SAE/MS Straight Threads)

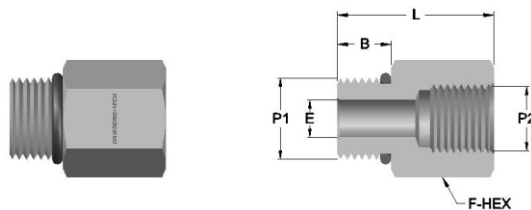

STANDARD CONFIGURATION DIMENSIONS

| Male SAE/MS Thread Size | Female SAE/MS Thread Size | Dimensions in mm | | | F-Hex (Inch) | Uniform 'O' Ring Size | Pressure Rating PSIG (Bar) | Dawsons-Tech Part No. |
|-------------------------|---------------------------|------------------|------|------|--------------|-----------------------|----------------------------|-----------------------|
| | | B | E | L | | | | |
| 9/16 - 18 | 7/16 - 20 | 9.9 | 7.1 | 31.0 | 15/16 | -906 | 4500 (306) | RA-9-7SAE |
| 3/4 - 16 | 7/16 - 20 | 11.2 | 9.9 | 24.9 | 7/8 | -908 | 4500 (306) | RA-12-7SAE |
| 3/4 - 16 | 9/16 - 18 | 11.2 | 10.6 | 35.8 | 1 | -908 | 4500 (306) | RA-12-9SAE |
| 7/8 - 14 | 9/16 - 18 | 12.7 | 12.7 | 32.8 | 1 | -910 | 3600 (245) | RA-14-9SAE |
| 7/8 - 14 | 3/4 - 16 | 12.7 | 12.7 | 39.6 | 1-3/16 | -910 | 3600 (245) | RA-14-12SAE |
| 1-1/16 - 12 | 3/4 - 16 | 15.0 | 16.7 | 38.6 | 1-1/4 | -912 | 3600 (245) | RA-17-12SAE |
| 1-5/16 - 12 | 1-1/16 - 12 | 15.0 | 22.3 | 49.3 | 1-5/8 | -916 | 2900 (198) | RA-21-17SAE |

Dimensions are for reference only and are subject to change.

Reducing Bushing (Male to Female NPT Threads)

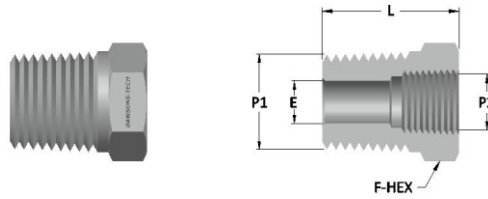

STANDARD CONFIGURATION DIMENSIONS

| Male NPT Thread Size | Reduced Female NPT Thread Size | Dimensions in mm | | F-Hex (Inch) | Pressure Rating PSIG (Bar) | Dawsons-Tech Part No. |
|----------------------|--------------------------------|------------------|------|--------------|----------------------------|-----------------------|
| | | E | L | | | |
| P1 | P2 | | | | | |
| 1/4 | 1/8 | 7.1 | 26.9 | 9/16 | 6000 (408) | RB-4N-2N |
| 3/8 | 1/8 | 8.6 | 21.8 | 11/16 | 6400 (435) | RB-6N-2N |
| 3/8 | 1/4 | 9.6 | 30.2 | 3/4 | 5300 (360) | RB-6N-4N |
| 1/2 | 1/8 | 8.6 | 27.4 | 7/8 | 6600 (450) | RB-8N-2N |
| 1/2 | 1/4 | 11.4 | 27.4 | 7/8 | 6400 (435) | RB-8N-4N |
| 1/2 | 3/8 | 11.9 | 35.8 | 7/8 | 4600 (315) | RB-8N-6N |
| 3/4 | 1/4 | 11.4 | 27.4 | 1-1/16 | 6400 (435) | RB-12N-4N |
| 3/4 | 3/8 | 15.0 | 27.4 | 1-1/16 | 5300 (360) | RB-12N-6N |
| 3/4 | 1/2 | 15.7 | 41.4 | 1-1/16 | 4900 (333) | RB-12N-8N |
| 1 | 1/4 | 11.4 | 34.8 | 1-3/8 | 4600 (315) | RB-16N-4N |
| 1 | 3/8 | 15.0 | 34.8 | 1-3/8 | 4600 (315) | RB-16N-6N |
| 1 | 1/2 | 18.5 | 34.8 | 1-3/8 | 4600 (315) | RB-16N-8N |
| 1 | 3/4 | 22.4 | 47.0 | 1-3/8 | 4200 (286) | RB-16N-12N |

Dimensions are for reference only and are subject to change.

Reducing Bushing (Male to Female ISO Tapered (BSPT) Threads)

| Male BSPT Thread Size | Reduced Female BSPT Thread Size | Dimensions in mm | | F-Hex (Inch) | Pressure Rating PSIG (Bar) | Dawsons-Tech Part No. |
|-----------------------|---------------------------------|------------------|------|--------------|----------------------------|-----------------------|
| | | E | L | | | |
| P1 | P2 | | | | | |
| 1/4 | 1/8 | 7.1 | 26.9 | 9/16 | 6000 (408) | RB-4RT-2RT |
| 3/8 | 1/4 | 9.6 | 30.2 | 3/4 | 5300 (360) | RB-6RT-4RT |
| 1/2 | 1/4 | 11.4 | 27.4 | 7/8 | 6400 (435) | RB-8RT-4RT |
| 1/2 | 3/8 | 11.9 | 35.8 | 7/8 | 4600 (315) | RB-8RT-6RT |

Dimensions are for reference only and are subject to change.

Hex Coupling (Female NPT Threads)

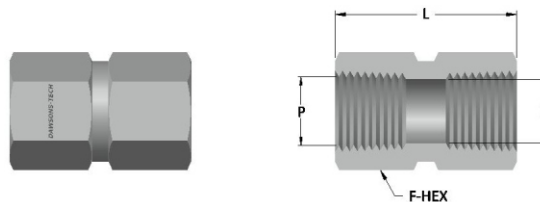

STANDARD CONFIGURATION DIMENSIONS

| NPT Thread Size | Dimensions in mm | | F-Hex (Inch) | Pressure Rating PSIG (Bar) | Dawsons-Tech Part No. |
|-----------------|------------------|------|--------------|----------------------------|-----------------------|
| | E | L | | | |
| P | | | | | |
| 1/8 | 8.6 | 20.6 | 9/16 | 6400 (435) | HC-2N |
| 1/4 | 11.4 | 30.2 | 3/4 | 6600 (450) | HC-4N |
| 3/8 | 15.0 | 33.3 | 7/8 | 5300 (360) | HC-6N |
| 1/2 | 18.5 | 39.6 | 1-1/16 | 5200 (354) | HC-8N |
| 3/4 | 23.9 | 41.1 | 1-1/4 | 4300 (292) | HC-12N |
| 1 | 29.7 | 50.8 | 1-5/8 | 4500 (306) | HC-16N |

Dimensions are for reference only and are subject to change.

Hex Coupling (Female ISO Tapered (BSPT) Threads)

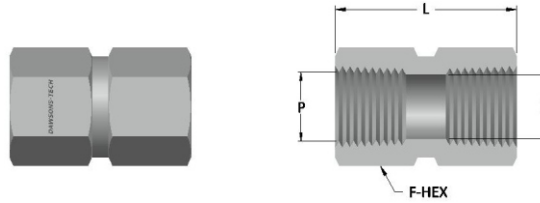

STANDARD CONFIGURATION DIMENSIONS

| BSPT Thread Size | Dimensions in mm | | F-Hex (Inch) | Pressure Rating PSIG (Bar) | Dawsons-Tech Part No. | |
|------------------|------------------|------|--------------|----------------------------|-----------------------|--------|
| | P | E | | | | L |
| 1/8 | | 8.4 | 20.6 | 9/16 | 6400 (435) | HC-2RT |
| 1/4 | | 11.2 | 30.2 | 3/4 | 6600 (450) | HC-4RT |
| 3/8 | | 14.7 | 33.3 | 7/8 | 5300 (360) | HC-6RT |
| 1/2 | | 18.3 | 39.6 | 1-1/16 | 5200 (354) | HC-8RT |

Dimensions are for reference only and are subject to change.

Hex Reducing Coupling (Female NPT Threads)

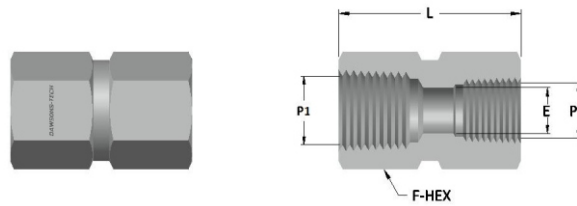

STANDARD CONFIGURATION DIMENSIONS

| NPT Thread Size | Reduced NPT Thread Size | Dimensions in mm | | F-Hex (Inch) | Pressure Rating PSIG (Bar) | Dawsons-Tech Part No. | | |
|-----------------|-------------------------|------------------|----|--------------|----------------------------|-----------------------|------------|-------------|
| | | P1 | P2 | | | | E | L |
| 1/4 | 1/8 | | | 8.6 | 31.0 | 3/4 | 6600 (450) | HRC-4N-2N |
| 3/8 | 1/8 | | | 8.6 | 31.0 | 7/8 | 5300 (360) | HRC-6N-2N |
| 3/8 | 1/4 | | | 11.4 | 35.1 | 7/8 | 5300 (360) | HRC-6N-4N |
| 1/2 | 1/8 | | | 8.6 | 39.6 | 1-1/16 | 5200 (354) | HRC-8N-2N |
| 1/2 | 1/4 | | | 11.4 | 44.4 | 1-1/16 | 5200 (354) | HRC-8N-4N |
| 1/2 | 3/8 | | | 15.0 | 45.0 | 1-1/16 | 5200 (354) | HRC-8N-6N |
| 3/4 | 1/4 | | | 11.4 | 46.0 | 1-1/4 | 4300 (292) | HRC-12N-4N |
| 3/4 | 3/8 | | | 15.0 | 46.0 | 1-1/4 | 4300 (292) | HRC-12N-6N |
| 3/4 | 1/2 | | | 18.5 | 52.3 | 1-1/4 | 4300 (292) | HRC-12N-8N |
| 1 | 1/2 | | | 18.5 | 55.6 | 1-5/8 | 4500 (306) | HRC-16N-8N |
| 1 | 3/4 | | | 23.9 | 57.2 | 1-5/8 | 4500 (306) | HRC-16N-12N |

Dimensions are for reference only and are subject to change.

Hex Reducing Coupling (Female ISO Tapered (BSPT) Threads)

| BSPT Thread Size | Reduced BSPT Thread Size | Dimensions in mm | | F-Hex (Inch) | Pressure Rating PSIG (Bar) | Dawsons-Tech Part No. | | |
|------------------|--------------------------|------------------|----|--------------|----------------------------|-----------------------|------------|-------------|
| | | P1 | P2 | | | | E | L |
| 3/8 | 1/4 | | | 11.2 | 35.1 | 7/8 | 5300 (360) | HRC-6RT-4RT |
| 1/2 | 1/4 | | | 11.2 | 44.4 | 1-1/16 | 4900 (333) | HRC-8RT-2RT |
| 1/2 | 3/8 | | | 14.7 | 45.2 | 1-1/16 | 4900 (333) | HRC-8RT-6RT |

Dimensions are for reference only and are subject to change.

Male Elbow (Male NPT Threads)

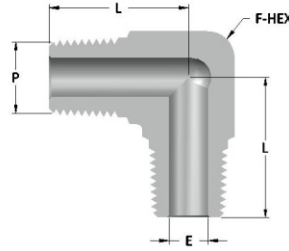

STANDARD CONFIGURATION DIMENSIONS

| NPT Thread Size | Dimensions in mm | | F-Hex (Inch) | Pressure Rating PSIG (Bar) | Dawsons-Tech Part No. |
|-----------------|------------------|------|--------------|----------------------------|-----------------------|
| | P | E | | | |
| 1/8 | 4.8 | 19.8 | 7/16 | 9100 (620) | ME-2N |
| 1/4 | 7.1 | 27.7 | 9/16 | 7500 (510) | ME-4N |
| 3/8 | 9.6 | 31.0 | 11/16 | 7200 (490) | ME-6N |
| 1/2 | 11.9 | 37.4 | 7/8 | 5800 (395) | ME-8N |
| 3/4 | 15.7 | 40.4 | 1-1/16 | 6400 (438) | ME-12N |
| 1 | 22.4 | 50.1 | 1-5/16 | 4600 (315) | ME-16N |

Dimensions are for reference only and are subject to change.

Male Tee (Male NPT Threads)

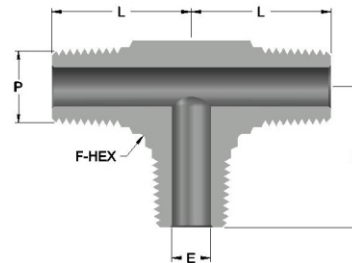
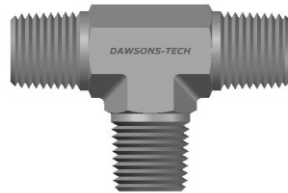

STANDARD CONFIGURATION DIMENSIONS

| NPT Thread Size | Dimensions in mm | | F-Hex (Inch) | Pressure Rating PSIG (Bar) | Dawsons-Tech Part No. |
|-----------------|------------------|------|--------------|----------------------------|-----------------------|
| | P | E | | | |
| 1/8 | 4.8 | 19.8 | 7/16 | 5500 (375) | MT-2N |
| 1/4 | 7.1 | 27.7 | 9/16 | 5600 (380) | MT-4N |
| 3/8 | 9.6 | 31.0 | 11/16 | 5600 (380) | MT-6N |
| 1/2 | 11.9 | 37.4 | 7/8 | 4500 (306) | MT-8N |
| 3/4 | 15.7 | 40.4 | 1-1/16 | 3500 (238) | MT-12N |
| 1 | 22.4 | 50.1 | 1-5/16 | 3500 (238) | MT-16N |

Dimensions are for reference only and are subject to change.

Female Elbow (Female NPT Threads)

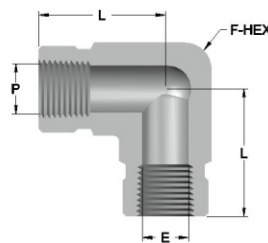

STANDARD CONFIGURATION DIMENSIONS

| NPT Thread Size | Dimensions in mm | | F-Hex (Inch) | Pressure Rating PSIG (Bar) | Dawsons-Tech Part No. |
|-----------------|------------------|------|--------------|----------------------------|-----------------------|
| | P | E | | | |
| 1/8 | 8.6 | 16.7 | 9/16 | 5500 (375) | FE-2N |
| 1/4 | 11.4 | 22.3 | 3/4 | 5600 (380) | FE-4N |
| 3/8 | 15.0 | 25.9 | 7/8 | 5000 (340) | FE-6N |
| 1/2 | 18.5 | 31.2 | 1-1/16 | 4500 (306) | FE-8N |
| 3/4 | 23.9 | 34.5 | 1-5/16 | 3500 (238) | FE-12N |
| 1 | 29.7 | 41.4 | 1-5/8 | 3900 (270) | FE-16N |

Dimensions are for reference only and are subject to change.

Female Elbow (Female ISO Tapered (BSPT) Threads)

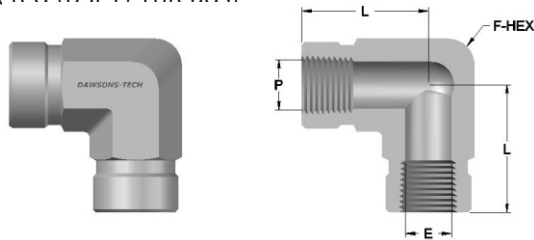

STANDARD CONFIGURATION DIMENSIONS

| BSPT Thread Size | Dimensions in mm | | F-Hex (Inch) | Pressure Rating PSIG (Bar) | Dawsons-Tech Part No. |
|------------------|------------------|------|--------------|----------------------------|-----------------------|
| | P | E | | | |
| 1/4 | 11.4 | 22.3 | 3/4 | 5600 (380) | FE-4RT |
| 3/8 | 15.0 | 25.9 | 7/8 | 5000 (340) | FE-6RT |
| 1/2 | 18.5 | 31.2 | 1-1/16 | 4500 (306) | FE-8RT |

Dimensions are for reference only and are subject to change.

Female Tee (Female NPT Threads)

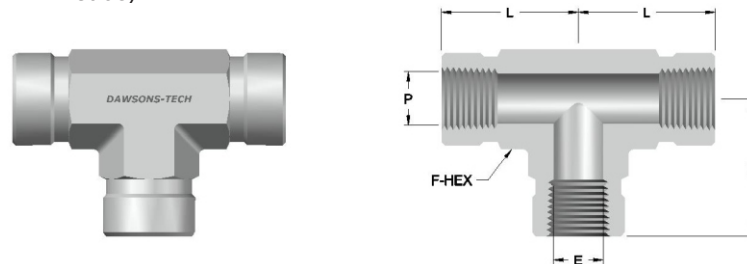

STANDARD CONFIGURATION DIMENSIONS

| NPT Thread Size | Dimensions in mm | | F-Hex (Inch) | Pressure Rating PSIG (Bar) | Dawsons-Tech Part No. |
|-----------------|------------------|------|--------------|----------------------------|-----------------------|
| | P | E | | | |
| 1/8 | 8.6 | 16.7 | 9/16 | 5500 (375) | FT-2N |
| 1/4 | 11.4 | 22.3 | 3/4 | 5600 (380) | FT-4N |
| 3/8 | 15.0 | 25.9 | 7/8 | 5600 (380) | FT-6N |
| 1/2 | 18.5 | 31.2 | 1-1/16 | 4500 (306) | FT-8N |
| 3/4 | 23.9 | 34.5 | 1-5/16 | 3500 (238) | FT-12N |
| 1 | 29.7 | 41.4 | 1-5/8 | 3900 (265) | FT-16N |

Dimensions are for reference only and are subject to change.

Female Tee (Female ISO Tapered (BSPT) Threads)

| BSPT Thread Size | Dimensions in mm | | F-Hex (Inch) | Pressure Rating PSIG (Bar) | Dawsons-Tech Part No. |
|------------------|------------------|------|--------------|----------------------------|-----------------------|
| | P | E | | | |
| 1/4 | 11.2 | 22.3 | 3/4 | 5600 (380) | FT-4RT |
| 3/8 | 14.7 | 25.9 | 7/8 | 5600 (380) | FT-6RT |
| 1/2 | 18.3 | 31.2 | 1-1/16 | 4500 (306) | FT-8RT |

Dimensions are for reference only and are subject to change.

Female Cross (Female NPT Threads)

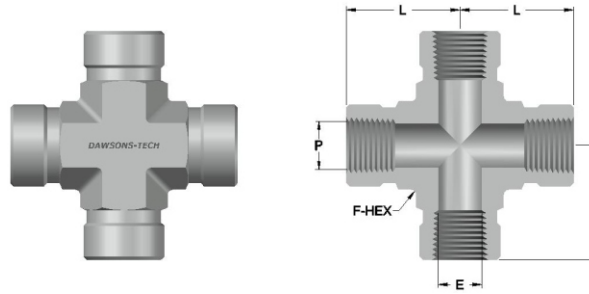

STANDARD CONFIGURATION DIMENSIONS

| NPT Thread Size | Dimensions in mm | | F-Hex (Inch) | Pressure Rating PSIG (Bar) | Dawsons-Tech Part No. |
|-----------------|------------------|------|--------------|----------------------------|-----------------------|
| | P | E | | | |
| 1/8 | 8.6 | 16.7 | 9/16 | 5500 (375) | FC-2N |
| 1/4 | 11.4 | 22.3 | 3/4 | 5600 (380) | FC-4N |
| 3/8 | 15.0 | 25.9 | 7/8 | 5600 (380) | FC-6N |
| 1/2 | 18.5 | 31.2 | 1-1/16 | 4500 (306) | FC-8N |
| 3/4 | 23.9 | 34.5 | 1-5/16 | 3500 (238) | FC-12N |
| 1 | 29.7 | 41.4 | 1-5/8 | 3900 (265) | FC-16N |

Dimensions are for reference only and are subject to change.

Street Elbow (Female to Male NPT Threads)

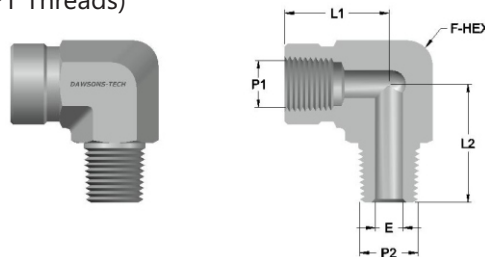

STANDARD CONFIGURATION DIMENSIONS

| Female NPT Thread Size | Male NPT Thread Size | Dimensions in mm | | | F-Hex (Inch) | Pressure Rating PSIG (Bar) | Dawsons-Tech Part No. |
|------------------------|----------------------|------------------|------|------|--------------|----------------------------|-----------------------|
| | | E | L1 | L2 | | | |
| P1 | P2 | | | | | | |
| 1/8 | 1/8 | 4.8 | 16.7 | 19.8 | 9/16 | 5500 (375) | SE-2N |
| 1/4 | 1/4 | 7.1 | 22.3 | 27.7 | 3/4 | 5600 (380) | SE-4N |
| 3/8 | 3/8 | 9.6 | 25.9 | 31.0 | 7/8 | 5600 (380) | SE-6N |
| 1/2 | 1/2 | 11.9 | 31.2 | 37.3 | 1-1/16 | 4500 (306) | SE-8N |
| 3/4 | 3/4 | 15.7 | 34.5 | 40.4 | 1-5/16 | 3500 (238) | SE-12N |
| 1 | 1 | 22.4 | 41.4 | 50.1 | 1-5/8 | 3900 (265) | SE-16N |

Dimensions are for reference only and are subject to change.

Reducing Street Elbow (Female to Male NPT Threads)

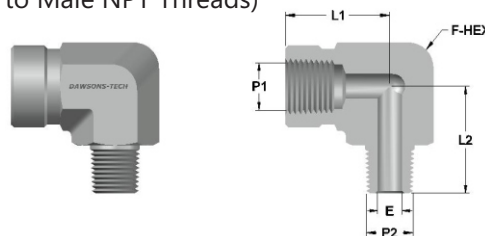

STANDARD CONFIGURATION DIMENSIONS

| Female NPT Thread Size | Reduced Male NPT Thread Size | Dimensions in mm | | | F-Hex (Inch) | Pressure Rating PSIG (Bar) | Dawsons-Tech Part No. |
|------------------------|------------------------------|------------------|------|------|--------------|----------------------------|-----------------------|
| | | E | L1 | L2 | | | |
| P1 | P2 | | | | | | |
| 1/4 | 1/8 | 4.8 | 22.3 | 22.8 | 3/4 | 5500 (375) | RSE-4N-2N |
| 3/8 | 1/4 | 7.1 | 25.6 | 31.0 | 7/8 | 5500 (375) | RSE-6N-4N |
| 1/2 | 1/4 | 7.1 | 32.5 | 32.5 | 1-1/16 | 4500 (306) | RSE-8N-4N |
| 1/2 | 3/8 | 9.6 | 32.5 | 32.5 | 1-1/16 | 4500 (306) | RSE-8N-6N |

Dimensions are for reference only and are subject to change.

Street Tee (Female and Male NPT Threads)

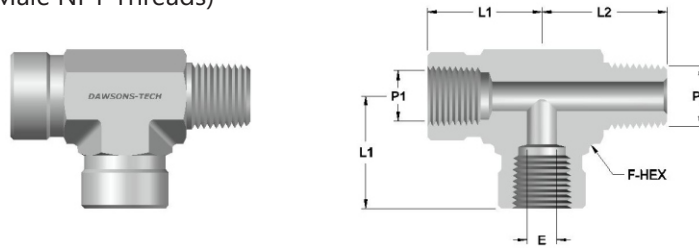

STANDARD CONFIGURATION DIMENSIONS

| Female NPT Thread Size | Male NPT Thread Size | Dimensions in mm | | | F-Hex (Inch) | Pressure Rating PSIG (Bar) | Dawsons-Tech Part No. |
|------------------------|----------------------|------------------|------|------|--------------|----------------------------|-----------------------|
| | | P1 | P2 | E | | | |
| 1/8 | 1/8 | 4.8 | 16.7 | 19.8 | 9/16 | 5500 (375) | ST-2N |
| 1/4 | 1/4 | 7.1 | 22.3 | 27.7 | 3/4 | 5600 (380) | ST-4N |
| 3/8 | 3/8 | 9.6 | 25.9 | 31.0 | 7/8 | 5600 (380) | ST-6N |
| 1/2 | 1/2 | 11.9 | 31.2 | 37.3 | 1-1/16 | 4500 (306) | ST-8N |
| 3/4 | 3/4 | 15.7 | 34.5 | 40.4 | 1-5/16 | 3500 (238) | ST-12N |
| 1 | 1 | 22.4 | 41.4 | 50.1 | 1-5/8 | 3900 (265) | ST-16N |

Dimensions are for reference only and are subject to change.

Branch Tee (Female and Male NPT Threads)

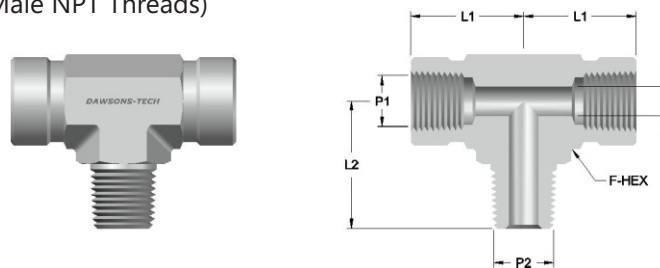

STANDARD CONFIGURATION DIMENSIONS

| Female NPT Thread Size | Male NPT Thread Size | Dimensions in mm | | | F-Hex (Inch) | Pressure Rating PSIG (Bar) | Dawsons-Tech Part No. |
|------------------------|----------------------|------------------|------|------|--------------|----------------------------|-----------------------|
| | | P1 | P2 | E | | | |
| 1/8 | 1/8 | 4.8 | 16.7 | 19.8 | 9/16 | 5500 (375) | BT-2N |
| 1/4 | 1/4 | 7.1 | 22.3 | 27.7 | 3/4 | 5600 (380) | BT-4N |
| 3/8 | 3/8 | 9.6 | 25.9 | 31.0 | 7/8 | 5600 (380) | BT-6N |
| 1/2 | 1/2 | 11.9 | 31.2 | 37.3 | 1-1/16 | 4500 (306) | BT-8N |
| 3/4 | 3/4 | 15.7 | 34.5 | 40.4 | 1-5/16 | 3500 (238) | BT-12N |
| 1 | 1 | 22.4 | 41.4 | 50.1 | 1-5/8 | 3900 (265) | BT-16N |

Dimensions are for reference only and are subject to change.

Union Ball Joint (Female NPT Threads)

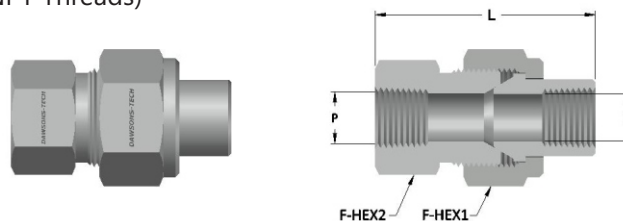

STANDARD CONFIGURATION DIMENSIONS

| NPT Thread Size | Dimensions in mm | | F-Hex1 (Inch) | F-Hex2 (Inch) | Pressure Rating PSIG (Bar) | Dawsons-Tech Part No. |
|-----------------|------------------|------|---------------|---------------|----------------------------|-----------------------|
| | P | E | | | | |
| 1/8 | 6.8 | 46.0 | 1-1/8 | 1-1/16 | 8400 (572) | UBJ-2N |
| 1/4 | 9.1 | 59.4 | 1-3/8 | 1-3/16 | 6600 (450) | UBJ-4N |
| 3/8 | 13.2 | 63.5 | 1-1/8 | 1-5/16 | 5300 (360) | UBJ-6N |
| 1/2 | 15.7 | 68.3 | 1-3/4 | 1-5/8 | 6000 (408) | UBJ-8N |
| 3/4 | 22.4 | 79.2 | 2-1/8 | 1-7/8 | 4600 (313) | UBJ-12N |
| 1 | 26.2 | 90.4 | 2-1/2 | 2-3/8 | 6800 (462) | UBJ-16N |

Dimensions are for reference only and are subject to change.

Pipe Cap (Female NPT Threads)

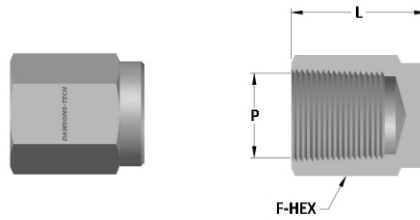

STANDARD CONFIGURATION DIMENSIONS

| NPT Thread Size | Dimensions in mm | | F-Hex (Inch) | Pressure Rating PSIG (Bar) | Dawsons-Tech Part No. |
|-----------------|------------------|---|--------------|----------------------------|-----------------------|
| | P | L | | | |
| 1/8 | 19.1 | | 9/16 | 6400 (435) | PC-2N |
| 1/4 | 23.1 | | 3/4 | 6600 (450) | PC-4N |
| 3/8 | 26.2 | | 7/8 | 5300 (360) | PC-6N |
| 1/2 | 34.0 | | 1-1/16 | 5200 (354) | PC-8N |
| 3/4 | 36.6 | | 1-1/4 | 4300 (292) | PC-12N |
| 1 | 41.1 | | 1-5/8 | 4500 (306) | PC-16N |

Dimensions are for reference only and are subject to change.

Pipe Plug (Male NPT Threads)

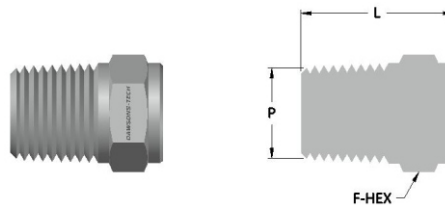

STANDARD CONFIGURATION DIMENSIONS

| NPT Thread Size | Dimensions in mm | | F-Hex (Inch) | Pressure Rating PSIG (Bar) | Dawsons-Tech Part No. |
|-----------------|------------------|---|--------------|----------------------------|-----------------------|
| | P | L | | | |
| 1/8 | 19.1 | | 7/16 | 9700 (660) | PP-2N |
| 1/4 | 24.4 | | 9/16 | 8000 (544) | PP-4N |
| 3/8 | 25.1 | | 11/16 | 7600 (517) | PP-6N |
| 1/2 | 30.7 | | 7/8 | 7000 (477) | PP-8N |
| 3/4 | 30.7 | | 1-1/16 | 6800 (463) | PP-12N |
| 1 | 38.1 | | 1-3/8 | 4900 (333) | PP-16N |

Dimensions are for reference only and are subject to change.

Hollow Hex Plug (Male SAE/MS Straight Threads)

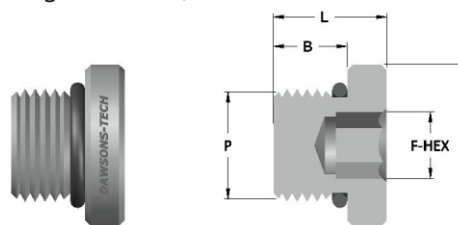

STANDARD CONFIGURATION DIMENSIONS

| NPT Thread Size | Dimensions in mm | | | F-Hex (Inch) | Uniform 'O' Ring Size | Dawsons-Tech Part No. |
|-----------------|------------------|------|------|--------------|-----------------------|-----------------------|
| | B | C | L | | | |
| 7/16 - 20 | 9.1 | 14.2 | 11.4 | 3/16 | -904 | HHPST-7SAE |
| 9/16 - 18 | 9.9 | 17.5 | 12.2 | 1/4 | -906 | HHPST-9SAE |
| 3/4 - 16 | 11.2 | 22.4 | 14.2 | 5/16 | -908 | HHPST-12SAE |
| 1-1/16 - 12 | 15.0 | 31.8 | 19.1 | 9/16 | -912 | HHPST-17SAE |
| 1-5/16 - 12 | 15.0 | 38.1 | 19.1 | 5/8 | -916 | HHPST-21SAE |

Dimensions are for reference only and are subject to change.

Hollow Hex Plug (Male NPT Threads)

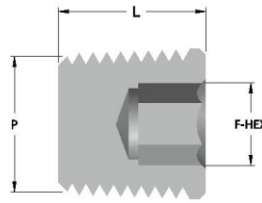

STANDARD CONFIGURATION DIMENSIONS

| NPT Thread Size | Dimensions in mm | | F-Hex (Inch) | Dawsons-Tech Part No. |
|-----------------|------------------|--|--------------|-----------------------|
| P | L | | | |
| 1/8 | 10.4 | | 3/16 | HHP-2N |
| 1/4 | 15.0 | | 1/4 | HHP-4N |
| 3/8 | 15.0 | | 5/16 | HHP-6N |
| 1/2 | 19.3 | | 3/8 | HHP-8N |

Dimensions are for reference only and are subject to change.

Hollow Hex Plug (Male BSPT Threads)

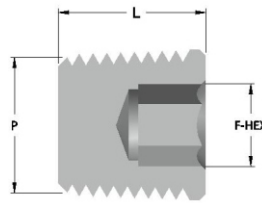

STANDARD CONFIGURATION DIMENSIONS

| BSPT Thread Size | Dimensions in mm | | F-Hex (Inch) | Dawsons-Tech Part No. |
|------------------|------------------|--|--------------|-----------------------|
| P | L | | | |
| 1/8 | 10.4 | | 3/16 | HHP-2RT |
| 1/4 | 15.0 | | 1/4 | HHP-4RT |
| 3/8 | 15.0 | | 5/16 | HHP-6RT |
| 1/2 | 19.3 | | 3/8 | HHP-8RT |

Dimensions are for reference only and are subject to change.

Hex Head Plug (Male SAE/MS Straight Threads)

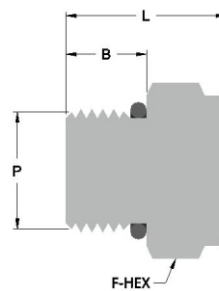

STANDARD CONFIGURATION DIMENSIONS

| SAE/MS Thread Size | Dimensions in mm | | F-Hex (Inch) | Uniform 'O' Ring Size | Dawsons-Tech Part No. |
|--------------------|------------------|------|--------------|-----------------------|-----------------------|
| P | B | L | | | |
| 7/16 - 20 | 9.1 | 19.3 | 9/16 | -904 | HHPSAE-7 |
| 9/16 - 18 | 9.9 | 20.8 | 11/16 | -906 | HHPSAE-9 |
| 3/4 - 16 | 11.2 | 22.6 | 7/8 | -908 | HHPSAE-12 |
| 1-1/16 - 12 | 15.0 | 28.4 | 1-1/4 | -912 | HHPSAE-17 |
| 1-5/16 - 12 | 15.0 | 30.0 | 1-1/2 | -916 | HHPSAE-21 |

Dimensions are for reference only and are subject to change.

Reducing Adapter (Tube Butt Weld to Tube Socket Weld)

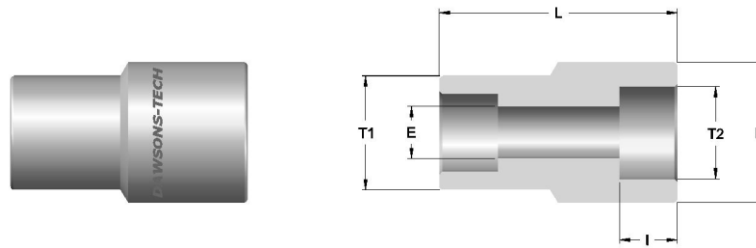

STANDARD CONFIGURATION DIMENSIONS

| Tube OD | Tube OD | Dimensions in mm | | | | Pressure Rating PSIG (Bar) | Dawsons-Tech Part No. |
|---------|---------|------------------|----------------|-----|------|----------------------------|-----------------------|
| T1 | T2 | D | Min. Opening E | I | L | | |
| 1/4 | 1/8 | 7.4 | 2.3 | 2.5 | 14.9 | 12,600 (860) | RA-4TBW-2TSW |
| 3/8 | 1/4 | 12.2 | 4.8 | 7.1 | 19.1 | 8200 (560) | RA-6TBW-4TSW |
| 1/2 | 1/4 | 12.7 | 4.8 | 7.1 | 22.4 | 7500 (510) | RA-8TBW-4TSW |
| 1/2 | 3/8 | 15.2 | 8.4 | 7.9 | 22.4 | 7500 (510) | RA-8TBW-6TSW |
| 3/4 | 1/2 | 19.1 | 10.4 | 9.7 | 28.4 | 6300 (430) | RA-12TBW-8TSW |
| 1 | 1/2 | 18.5 | 10.4 | 9.7 | 35.1 | 5300 (360) | RA-16TBW-8TSW |

Dimensions are for reference only and are subject to change.

Union (Tube Socket Weld)

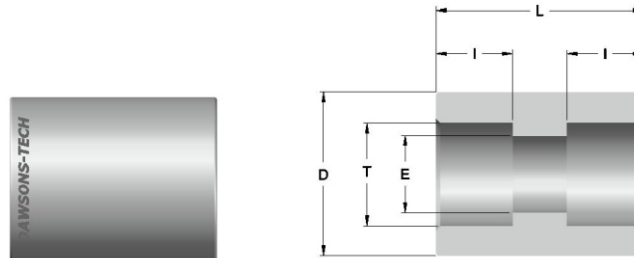

STANDARD CONFIGURATION DIMENSIONS

| Tube OD | Dimensions in mm | | | | Pressure Rating PSIG (Bar) | Dawsons-Tech Part No. |
|---------|------------------|----------------|------|------|----------------------------|-----------------------|
| T | D | Min. Opening E | I | L | | |
| 1/4 | 12.2 | 4.8 | 7.1 | 19.1 | 10,300 (700) | U-4TSW |
| 3/8 | 15.2 | 7.1 | 7.9 | 22.4 | 8100 (550) | U-6TSW |
| 1/2 | 18.5 | 10.4 | 9.7 | 26.9 | 6600 (450) | U-8TSW |
| 3/4 | 28.4 | 15.7 | 11.2 | 33.3 | 5900 (400) | U-12TSW |
| 1 | 34.6 | 22.4 | 15.7 | 36.6 | 5600 (380) | U-16TSW |

Dimensions are for reference only and are subject to change.

Union Elbow (Tube Socket Weld)

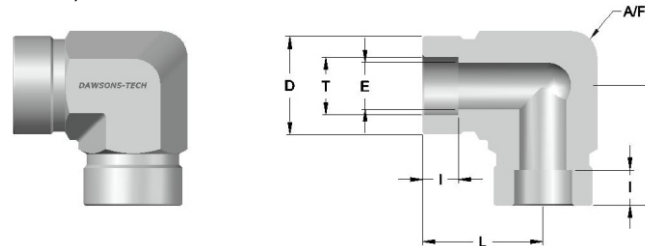

STANDARD CONFIGURATION DIMENSIONS

| Tube OD | Dimensions in mm | | | | A/F (Inch) | Pressure Rating PSIG (Bar) | Dawsons-Tech Part No. |
|---------|------------------|----------------|------|------|------------|----------------------------|-----------------------|
| T | D | Min. Opening E | I | L | | | |
| 1/4 | 13.5 | 4.8 | 7.1 | 21.8 | 9/16 | 10,300 (700) | UE-4TSW |
| 3/8 | 17.5 | 7.1 | 7.9 | 25.4 | 11/16 | 8100 (550) | UE-6TSW |
| 1/2 | 20.6 | 10.4 | 9.7 | 29.7 | 13/16 | 6600 (450) | UE-8TSW |
| 3/4 | 28.6 | 15.7 | 11.2 | 39.6 | 1-1/8 | 5900 (400) | UE-12TSW |
| 1 | 36.8 | 22.4 | 15.7 | 48.8 | 1-11/16 | 5600 (380) | UE-16TSW |

Dimensions are for reference only and are subject to change.

Union Tee (Tube Socket Weld)

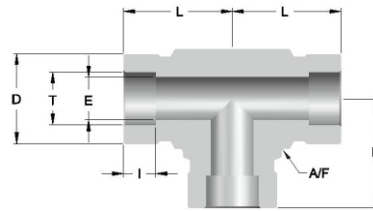

STANDARD CONFIGURATION DIMENSIONS

| Tube OD | Dimensions in mm | | | | A/F (Inch) | Pressure Rating PSIG (Bar) | Dawsons-Tech Part No. |
|---------|------------------|----------------|------|------|------------|----------------------------|-----------------------|
| T | D | Min. Opening E | I | L | | | |
| 1/8 | 9.0 | 2.3 | 2.5 | 15.0 | 7/16 | 12,600 (860) | UT-4TSW |
| 1/4 | 13.5 | 4.8 | 7.1 | 21.8 | 9/16 | 10,300 (700) | UT-4TSW |
| 3/8 | 17.5 | 7.1 | 7.9 | 26.4 | 11/16 | 8100 (550) | UT-6TSW |
| 1/2 | 20.6 | 10.4 | 9.7 | 29.7 | 13/16 | 6600 (450) | UT-8TSW |
| 3/4 | 28.6 | 15.7 | 11.2 | 39.6 | 1-1/8 | 5900 (400) | UT-12TSW |
| 1 | 36.8 | 22.4 | 15.7 | 48.8 | 1-11/16 | 5600 (380) | UT-16TSW |

Dimensions are for reference only and are subject to change.

Union Cross (Tube Socket Weld)

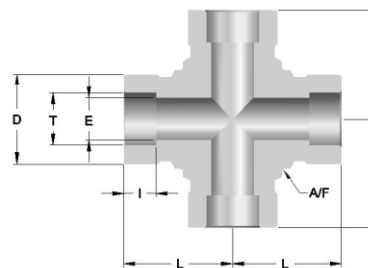
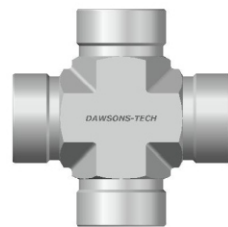

STANDARD CONFIGURATION DIMENSIONS

| Tube OD | Dimensions in mm | | | | A/F (Inch) | Pressure Rating PSIG (Bar) | Dawsons-Tech Part No. |
|---------|------------------|------|------|------|------------|----------------------------|-----------------------|
| T | Min. Opening D | E | I | L | | | |
| 1/4 | 13.5 | 4.8 | 7.1 | 21.8 | 9/16 | 10,300 (700) | TUC-4TSW |
| 3/8 | 17.5 | 7.1 | 7.9 | 26.4 | 11/16 | 8100 (550) | TUC-6TSW |
| 1/2 | 20.6 | 10.4 | 9.7 | 28.7 | 13/16 | 6600 (450) | TUC-8TSW |
| 3/4 | 30.5 | 15.7 | 11.2 | 37.9 | 1-1/8 | 5900 (400) | TUC-12TSW |
| 1 | 36.8 | 22.4 | 15.7 | 48.8 | 1-11/16 | 5600 (380) | TUC-16TSW |

Dimensions are for reference only and are subject to change.

Male Connector (Tube Socket Weld)

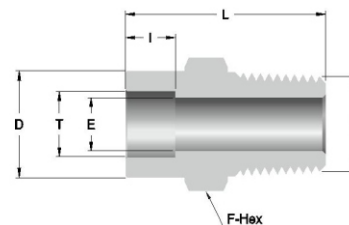
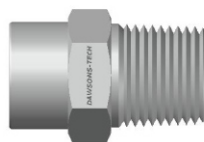

STANDARD CONFIGURATION DIMENSIONS

| Tube OD | Male NPT Thread | Dimensions in mm | | | | F-Hex (Inch) | Pressure Rating PSIG (Bar) | Dawsons-Tech Part No. |
|---------|-----------------|------------------|----------------|-----|------|--------------|----------------------------|-----------------------|
| T | P | D | Min. Opening E | I | L | | | |
| 1/4 | 1/4 | 12.2 | 4.8 | 7.1 | 29.2 | 9/16 | 8000 (545) | MC-4TSW-4N |
| 3/8 | 1/4 | 15.6 | 7.1 | 7.9 | 31.8 | 5/8 | 8000 (545) | MC-6TSW-4N |
| 3/8 | 3/8 | 15.8 | 7.1 | 7.9 | 31.8 | 11/16 | 7800 (530) | MC-6TSW-6N |
| 3/8 | 1/2 | 15.8 | 7.1 | 7.9 | 37.3 | 7/8 | 7800 (530) | MC-6TSW-8N |
| 1/2 | 1/4 | 18.5 | 7.1 | 9.7 | 33.3 | 3/4 | 6600 (445) | MC-8TSW-4N |
| 1/2 | 3/4 | 18.5 | 9.7 | 9.7 | 33.3 | 3/4 | 6600 (445) | MC-8TSW-6N |
| 1/2 | 1/2 | 18.5 | 10.4 | 9.7 | 38.9 | 7/8 | 6600 (445) | MC-8TSW-8N |

Dimensions are for reference only and are subject to change.

Male Elbow (Tube Socket Weld)

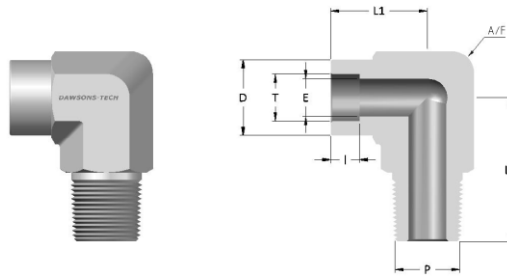

STANDARD CONFIGURATION DIMENSIONS

| Tube OD | Male NPT Thread | Dimensions in mm | | | | | A/F (Inch) | Pressure Rating PSIG (Bar) | Dawsons-Tech Part No. |
|---------|-----------------|------------------|----------------|-----|------|------|------------|----------------------------|-----------------------|
| T | P | D | Min. Opening E | I | L1 | L2 | | | |
| 1/4 | 1/4 | 13.5 | 4.8 | 7.1 | 20.1 | 24.0 | 9/16 | 8000 (545) | ME-4TSW-4N |
| 3/8 | 1/4 | 17.5 | 7.1 | 7.9 | 26.4 | 26.7 | 11/16 | 8000 (545) | ME-6TSW-4N |
| 3/8 | 3/8 | 17.5 | 7.1 | 7.9 | 24.6 | 26.2 | 11/16 | 7800 (530) | ME-6TSW-6N |
| 3/8 | 1/2 | 17.5 | 7.1 | 7.9 | 25.9 | 36.9 | 13/16 | 7800 (530) | ME-6TSW-8N |
| 1/2 | 1/2 | 20.6 | 10.4 | 9.7 | 27.4 | 36.9 | 13/16 | 6600 (445) | ME-8TSW-8N |

Dimensions are for reference only and are subject to change.

Female Connector (Tube Socket Weld)

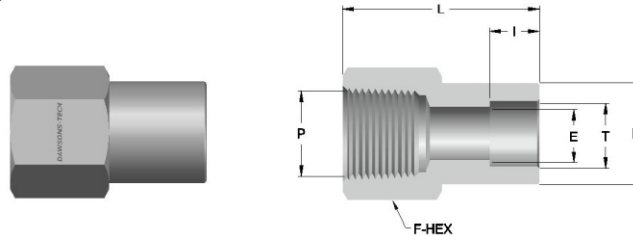

STANDARD CONFIGURATION DIMENSIONS

| Tube OD | Female NPT Thread | Dimensions in mm | | | | F-Hex (Inch) | Pressure Rating PSIG (Bar) | Dawsons-Tech Part No. |
|---------|-------------------|------------------|----------------|------|------|--------------|----------------------------|-----------------------|
| T | P | D | Min. Opening E | I | L | | | |
| 1/8 | 1/8 | 7.4 | 2.3 | 2.5 | 21.1 | 9/16 | 6500 (440) | FC-2TSW-2N |
| 1/4 | 1/8 | 12.2 | 4.8 | 7.1 | 26.7 | 9/16 | 6500 (440) | FC-4TSW-2N |
| 1/4 | 1/4 | 12.2 | 4.8 | 7.1 | 30.0 | 3/4 | 6600 (450) | FC-4TSW-4N |
| 3/8 | 1/4 | 15.2 | 7.1 | 7.9 | 31.5 | 3/4 | 6600 (450) | FC-6TSW-4N |
| 1/2 | 3/8 | 18.5 | 10.4 | 9.7 | 34.5 | 7/8 | 5300 (360) | FC-8TSW-6N |
| 1/2 | 1/2 | 18.5 | 10.4 | 9.7 | 40.4 | 1-1/16 | 4900 (335) | FC-8TSW-8N |
| 3/4 | 3/4 | 26.4 | 15.7 | 11.2 | 43.9 | 1-5/16 | 4600 (315) | FC-12TSW-12N |

Dimensions are for reference only and are subject to change.

Female Elbow (Tube Socket Weld)

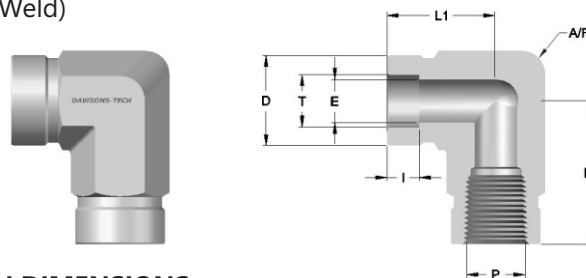

STANDARD CONFIGURATION DIMENSIONS

| Tube OD | Male NPT Thread | Dimensions in mm | | | | | A/F (Inch) | Pressure Rating PSIG (Bar) | Dawsons-Tech Part No. |
|---------|-----------------|------------------|----------------|-----|------|------|------------|----------------------------|-----------------------|
| T | P | D | Min. Opening E | I | L1 | L2 | | | |
| 1/4 | 1/4 | 13.5 | 4.8 | 7.1 | 22.9 | 29.7 | 3/4 | 6600 (445) | FE-4TSW-4N |
| 3/8 | 1/4 | 17.5 | 7.1 | 7.9 | 25.1 | 29.7 | 3/4 | 5300 (360) | FE-6TSW-4N |
| 3/8 | 1/2 | 17.5 | 7.1 | 7.9 | 28.7 | 39.6 | 1-1/16 | 4900 (335) | FE-6TSW-8N |
| 1/2 | 1/2 | 20.6 | 10.4 | 9.7 | 30.2 | 39.6 | 1-1/16 | 4900 (335) | FE-8TSW-8N |

Dimensions are for reference only and are subject to change.

Reducing Adapter (Pipe Butt Weld to Tube Socket Weld)

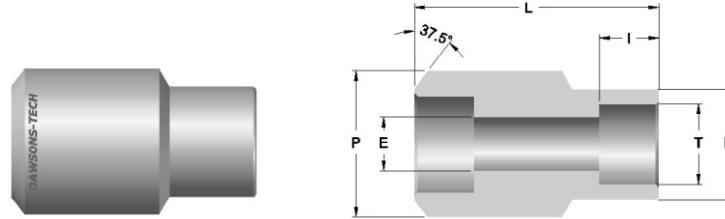

STANDARD CONFIGURATION DIMENSIONS

| Pipe Size | Tube OD | Dimensions in mm | | | | Pressure Rating PSIG (Bar) | Dawsons-Tech Part No. |
|-----------|---------|------------------|-------------------|------|------|-------------------------------|--------------------------|
| P | T | D | Min. Opening E | I | L | | |
| 1/4 | 1/4 | 12.2 | 4.8 | 7.1 | 22.4 | 10,300 (700) | RA-4PBW-4TSW |
| 3/8 | 3/8 | 15.2 | 7.1 | 7.9 | 26.2 | 8100 (550) | RA-6PBW-6TSW |
| 3/8 | 1/2 | 18.5 | 10.4 | 7.9 | 25.4 | 6600 (450) | RA-6PBW-8TSW |
| 1/2 | 1/4 | 12.2 | 4.8 | 7.1 | 28.4 | 7800 (530) | RA-8PBW-4TSW |
| 1/2 | 3/8 | 15.2 | 7.1 | 7.9 | 28.4 | 7800 (530) | RA-8PBW-6TSW |
| 1/2 | 1/2 | 18.5 | 10.4 | 9.7 | 30.2 | 6600 (450) | RA-8PBW-8TSW |
| 3/4 | 3/8 | 15.2 | 7.1 | 7.9 | 38.1 | 6600 (450) | RA-124PBW-6TSW |
| 3/4 | 1/2 | 18.5 | 10.4 | 9.7 | 38.1 | 6600 (450) | RA-12PBW-8TSW |
| 3/4 | 3/4 | 26.7 | 15.7 | 11.2 | 38.1 | 5900 (400) | RA-12PBW-12TSW |
| 1 | 3/8 | 15.2 | 7.1 | 7.9 | 35.1 | 6000 (410) | RA-16PBW-6TSW |
| 1 | 1/2 | 18.5 | 10.4 | 9.7 | 39.6 | 6000 (410) | RA-16PBW-8TSW |

Dimensions are for reference only and are subject to change.

Union (Pipe Socket Weld)

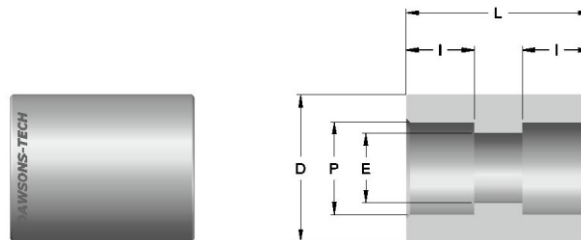

STANDARD CONFIGURATION DIMENSIONS

| Pipe Size | Dimensions in mm | | | | Pressure Rating PSIG (Bar) | Dawsons-Tech Part No. |
|-----------|------------------|-------------------|------|------|-------------------------------|--------------------------|
| P | D | Min. Opening E | I | L | | |
| 1/4 | 22.4 | 9.1 | 9.9 | 26.9 | 8100 (550) | U-4PSW |
| 3/8 | 26.2 | 12.4 | 9.9 | 28.4 | 7100 (480) | U-6PSW |
| 1/2 | 31.8 | 15.7 | 9.9 | 28.4 | 6800 (460) | U-8PSW |
| 3/4 | 37.3 | 20.8 | 13.0 | 44.5 | 5800 (400) | U-12PSW |
| 1 | 47.2 | 26.7 | 13.0 | 44.5 | 6100 (410) | U-16PSW |

Dimensions are for reference only and are subject to change.

MALE ADAPTER (Male NPT Threads to Tube End)

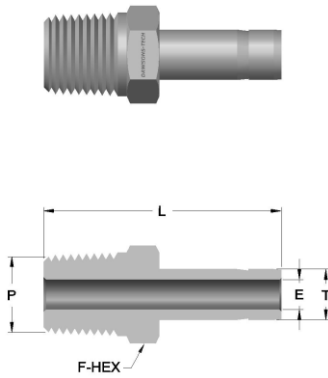

| Tube OD T | NPT Thread Size P | Dimensions in mm | | F-Hex (Inch) | Dawsons-Tech Part No. |
|-------------------|-------------------------|------------------|------|-----------------|--------------------------|
| | | E | L | | |
| Fractional | | | | | |
| 1/8 | 1/8 | 2.0 | 29.5 | 7/16 | MA-2-2N |
| 1/8 | 1/4 | 2.0 | 34.8 | 9/16 | MA-2-4N |
| 3/16 | 1/8 | 3.0 | 30.2 | 7/16 | MA-3-2N |
| 3/16 | 1/4 | 3.0 | 35.5 | 9/16 | MA-3-4N |
| 1/4 | 1/8 | 4.1 | 32.8 | 7/16 | MA-4-2N |
| 1/4 | 1/4 | 4.1 | 38.1 | 9/16 | MA-4-4N |
| 1/4 | 3/8 | 4.3 | 37.8 | 11/16 | MA-4-6N |
| 1/4 | 1/2 | 4.3 | 43.4 | 7/8 | MA-4-8N |
| 5/16 | 1/8 | 4.8 | 32.7 | 7/16 | MA-5-2N |
| 5/16 | 1/4 | 5.6 | 39.1 | 9/16 | MA-5-4N |
| 3/8 | 1/8 | 4.8 | 33.5 | 7/16 | MA-6-2N |
| 3/8 | 1/4 | 6.9 | 39.9 | 9/16 | MA-6-4N |
| 3/8 | 3/8 | 6.9 | 40.6 | 11/16 | MA-6-6N |
| 3/8 | 1/2 | 6.9 | 45.2 | 7/8 | MA-6-8N |
| 1/2 | 1/4 | 7.1 | 46.5 | 9/16 | MA-8-4N |
| 1/2 | 3/8 | 9.4 | 45.2 | 11/16 | MA-8-6N |
| 1/2 | 1/2 | 9.4 | 52.1 | 7/8 | MA-8-8N |
| 5/8 | 1/2 | 11.9 | 52.3 | 7/8 | MA-10-8N |
| 3/4 | 1/2 | 11.9 | 52.3 | 7/8 | MA-12-8N |
| 3/4 | 3/4 | 14.7 | 52.3 | 1-1/16 | MA-12-12N |
| 1 | 3/4 | 15.7 | 58.6 | 1-1/16 | MA-16-12N |
| 1 | 1 | 20.3 | 66.0 | 1-3/8 | MA-16-16N |
| Metric | | | | | |
| 6mm | 1/8 | 4.1 | 32.8 | 7/16 | MA-6M-2N |
| 6mm | 1/4 | 4.1 | 38.1 | 9/16 | MA-6M-4N |
| 8mm | 1/4 | 5.6 | 39.1 | 9/16 | MA-8M-4N |
| 10mm | 1/4 | 6.9 | 39.9 | 9/16 | MA-10M-4N |
| 10mm | 3/8 | 6.9 | 40.6 | 11/16 | MA-10M-6N |
| 10mm | 1/8 | 6.9 | 45.2 | 7/8 | MA-10M-8N |
| 12mm | 1/4 | 7.1 | 46.5 | 9/16 | MA-12M-4N |
| 12mm | 1/2 | 9.4 | 52.1 | 7/8 | MA-12M-8N |

Dimensions are for reference only and are subject to change.

MALE ADAPTER (Male ISO Tapered (BSPT) Threads to Tube End)

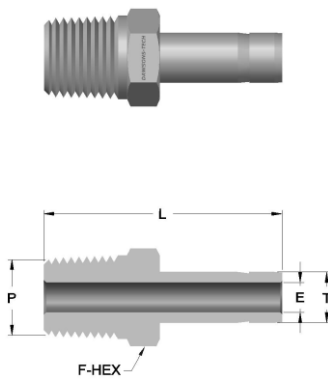

| Tube OD T | BSPT Thread Size P | Dimensions in mm | | F-Hex (Inch) | Dawsons-Tech Part No. |
|-------------------|--------------------------|------------------|------|-----------------|--------------------------|
| | | E | L | | |
| Fractional | | | | | |
| 1/8 | 1/8 | 2.0 | 29.5 | 7/16 | MA-2-2RT |
| 1/8 | 1/4 | 2.0 | 34.8 | 9/16 | MA-2-4RT |
| 1/4 | 1/8 | 4.1 | 32.8 | 7/16 | MA-4-2RT |
| 1/4 | 1/4 | 4.1 | 38.1 | 9/16 | MA-4-4RT |
| 3/8 | 1/4 | 6.9 | 39.9 | 9/16 | MA-6-4RT |
| 3/8 | 3/8 | 6.9 | 40.6 | 11/16 | MA-6-6RT |
| 3/8 | 1/2 | 6.9 | 45.2 | 7/8 | MA-6-8RT |
| 1/2 | 1/4 | 7.1 | 46.5 | 9/16 | MA-8-4RT |
| 1/2 | 3/8 | 9.4 | 45.2 | 11/16 | MA-8-6RT |
| 1/2 | 1/2 | 9.4 | 50.8 | 7/8 | MA-8-8RT |
| 3/4 | 3/4 | 14.7 | 52.3 | 1-1/16 | MA-12-12RT |
| 1 | 1 | 20.3 | 66.0 | 1-3/8 | MA-16-16RT |
| Metric | | | | | |
| 6mm | 1/8 | 4.1 | 32.8 | 7/16 | MA-6M-2RT |
| 6mm | 1/4 | 4.1 | 38.1 | 9/16 | MA-6M-4RT |
| 8mm | 1/4 | 5.6 | 39.1 | 9/16 | MA-8M-4RT |
| 10mm | 1/4 | 6.9 | 39.9 | 9/16 | MA-10M-4RT |
| 10mm | 3/8 | 6.9 | 40.6 | 11/16 | MA-10M-6RT |
| 12mm | 1/4 | 7.1 | 46.5 | 9/16 | MA-12M-4RT |
| 12mm | 3/8 | 9.4 | 45.2 | 11/16 | MA-12M-6RT |
| 12mm | 1/2 | 9.4 | 50.8 | 7/8 | MA-12M-8RT |

Dimensions are for reference only and are subject to change.

MALE ADAPTER (Male ISO Parallel (BSP) (According to DIN 3852 Part 2 Form B) to Tube End)

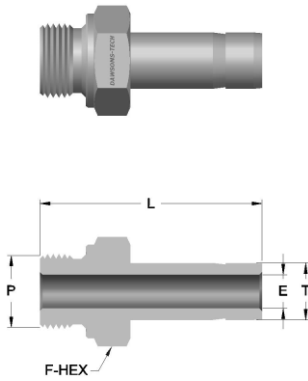

| Tube OD | BSP Thread Size | Dimensions in mm | | F-Hex (Inch) | Dawsons-Tech Part No. |
|-------------------|-----------------|------------------|------|--------------|-----------------------|
| | | T | P | | |
| Fractional | | | | | |
| 1/8 | 1/8 | 2.0 | 31.0 | 9/16 | MA-2-2RP |
| 1/8 | 1/4 | 2.0 | 35.8 | 3/4 | MA-2-4RP |
| 1/4 | 1/8 | 4.0 | 34.3 | 9/16 | MA-4-2RP |
| 1/4 | 1/4 | 4.1 | 38.1 | 3/4 | MA-4-4RP |
| 3/8 | 1/4 | 5.9 | 39.8 | 3/4 | MA-6-4RP |
| 3/8 | 3/8 | 6.9 | 40.6 | 7/8 | MA-6-6RP |
| 1/2 | 1/4 | 5.9 | 45.4 | 3/4 | MA-8-4RP |
| 1/2 | 3/8 | 7.9 | 46.2 | 7/8 | MA-8-6RP |
| 1/2 | 1/2 | 8.8 | 49.2 | 1-1/16 | MA-8-8RP |
| 3/4 | 3/4 | 13.9 | 54.8 | 1-1/4 | MA-12-12RP |
| 1 | 1 | 20.3 | 64.5 | 1-5/8 | MA-16-16RP |
| Metric | | | | | |
| 6mm | 1/8 | 4.0 | 34.3 | 9/16 | MA-6M-2RP |
| 6mm | 1/4 | 4.1 | 38.1 | 3/4 | MA-6M-4RP |
| 8mm | 1/4 | 5.6 | 39.8 | 3/4 | MA-8M-4RP |
| 10mm | 1/4 | 5.9 | 39.8 | 3/4 | MA-10M-4RP |
| 10mm | 3/8 | 6.9 | 40.6 | 7/8 | MA-10M-6RP |
| 10mm | 1/2 | 7.1 | 44.7 | 1-1/16 | MA-10M-8RP |
| 12mm | 1/4 | 5.9 | 45.4 | 3/4 | MA-12M-4RP |
| 12mm | 3/8 | 7.9 | 46.2 | 7/8 | MA-12M-6RP |
| 12mm | 1/2 | 8.8 | 49.2 | 1-1/16 | MA-12M-8RP |
| 18mm | 1/2 | 11.9 | 52.1 | 1-1/16 | MA-18M-8RP |
| 18mm | 3/4 | 13.9 | 54.8 | 1-1/4 | MA-18M-12RP |

Dimensions are for reference only and are subject to change.

MALE ADAPTER (Male ISO Parallel (BSP) (According to DIN 3852 Part 2 Form E) to Tube End)

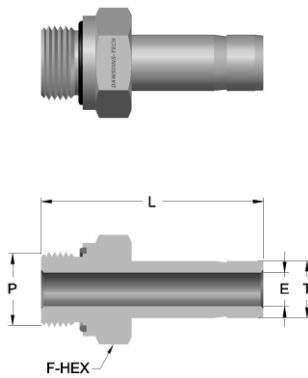

| Tube OD | BSP Thread Size | Dimensions in mm | | F-Hex (Inch) | Dawsons-Tech Part No. |
|-------------------|-----------------|------------------|------|--------------|-----------------------|
| | | T | P | | |
| Fractional | | | | | |
| 1/8 | 1/8 | 2.0 | 31.0 | 9/16 | MA-2-2EO |
| 1/8 | 1/4 | 2.0 | 35.8 | 3/4 | MA-2-4EO |
| 1/4 | 1/8 | 4.0 | 34.3 | 9/16 | MA-4-2EO |
| 1/4 | 1/4 | 4.1 | 38.1 | 3/4 | MA-4-4EO |
| 3/8 | 1/4 | 5.9 | 39.8 | 3/4 | MA-6-4EO |
| 3/8 | 3/8 | 6.9 | 40.6 | 7/8 | MA-6-6EO |
| 1/2 | 1/4 | 5.9 | 45.4 | 3/4 | MA-8-4EO |
| 1/2 | 3/8 | 7.9 | 46.2 | 7/8 | MA-8-6EO |
| 1/2 | 1/2 | 8.8 | 49.2 | 1-1/16 | MA-8-8EO |
| 3/4 | 3/4 | 13.9 | 54.8 | 1-1/4 | MA-12-12EO |
| 1 | 1 | 20.3 | 64.5 | 1-5/8 | MA-16-16EO |
| Metric | | | | | |
| 6mm | 1/8 | 4.0 | 34.3 | 9/16 | MA-6M-2EO |
| 6mm | 1/4 | 4.1 | 38.1 | 3/4 | MA-6M-4EO |
| 8mm | 1/4 | 5.6 | 39.8 | 3/4 | MA-8M-4EO |
| 10mm | 1/4 | 5.9 | 39.8 | 3/4 | MA-10M-4EO |
| 10mm | 3/8 | 6.9 | 40.6 | 7/8 | MA-10M-6EO |
| 10mm | 1/2 | 7.1 | 44.7 | 1-1/16 | MA-10M-8EO |
| 12mm | 1/4 | 5.9 | 45.4 | 3/4 | MA-12M-4EO |
| 12mm | 3/8 | 7.9 | 46.2 | 7/8 | MA-12M-6EO |
| 12mm | 1/2 | 8.8 | 49.2 | 1-1/16 | MA-12M-8EO |
| 18mm | 1/2 | 11.9 | 52.1 | 1-1/16 | MA-18M-8EO |
| 18mm | 3/4 | 13.9 | 54.8 | 1-1/4 | MA-18M-12EO |

Dimensions are for reference only and are subject to change.

FEMALE ADAPTER (Female NPT Threads to Tube End)

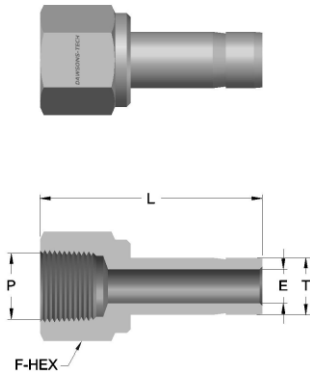

| Tube OD T | NPT Thread Size P | Dimensions in mm | | F-Hex (Inch) | Dawsons-Tech Part No. |
|-------------------|-------------------------|------------------|------|-----------------|--------------------------|
| | | E | L | | |
| Fractional | | | | | |
| 1/8 | 1/8 | 2.0 | 31.5 | 9/16 | FA-2-2N |
| 1/8 | 1/4 | 2.0 | 35.3 | 3/4 | FA-2-4N |
| 3/16 | 1/4 | 3.0 | 35.8 | 3/4 | FA-3-2N |
| 1/4 | 1/8 | 4.1 | 33.0 | 9/16 | FA-4-2N |
| 1/4 | 1/4 | 4.1 | 37.1 | 3/4 | FA-4-4N |
| 1/4 | 3/8 | 4.1 | 39.4 | 7/8 | FA-4-6N |
| 1/4 | 1/2 | 4.1 | 45.5 | 1-1/16 | FA-4-8N |
| 5/16 | 1/4 | 5.6 | 37.6 | 3/4 | FA-5-8N |
| 3/8 | 1/8 | 6.9 | 34.6 | 9/16 | FA-6-2N |
| 3/8 | 1/4 | 6.9 | 38.1 | 3/4 | FA-6-4N |
| 3/8 | 3/8 | 6.9 | 40.4 | 7/8 | FA-6-6N |
| 3/8 | 1/2 | 6.9 | 46.7 | 1-1/16 | FA-6-8N |
| 1/2 | 1/4 | 8.8 | 43.7 | 3/4 | FA-8-4N |
| 1/2 | 3/8 | 9.4 | 45.5 | 7/8 | FA-8-6N |
| 1/2 | 1/2 | 8.8 | 52.3 | 1-1/16 | FA-8-8N |
| 5/8 | 1/2 | 11.9 | 53.1 | 1-1/16 | FA-10-8N |
| 3/4 | 1/2 | 14.7 | 52.8 | 1-1/16 | FA-12-8N |
| 3/4 | 3/4 | 14.7 | 54.9 | 1-1/4 | FA-12-12N |
| 3/4 | 1 | 14.7 | 58.4 | 1-5/8 | FA-16-12N |
| 1 | 3/4 | 20.3 | 60.7 | 1-1/4 | FA-16-12N |
| 1 | 1 | 20.3 | 64.2 | 1-5/8 | FA-16-16N |
| Metric | | | | | |
| 6mm | 1/8 | 4.1 | 33.0 | 9/16 | FA-6M-2N |
| 6mm | 1/4 | 4.1 | 37.1 | 3/4 | FA-6M-4N |
| 8mm | 1/4 | 5.6 | 37.6 | 3/4 | FA-8M-4N |
| 10mm | 1/4 | 6.9 | 38.1 | 3/4 | FA-10M-4N |
| 10mm | 3/8 | 6.9 | 40.4 | 7/8 | FA-10M-6N |
| 10mm | 1/2 | 6.9 | 46.7 | 1-1/16 | FA-10M-8N |
| 12mm | 1/4 | 8.8 | 43.7 | 3/4 | FA-12M-8N |
| 12mm | 1/2 | 8.8 | 52.3 | 1-1/16 | FA-12M-8N |

Dimensions are for reference only and are subject to change.

FEMALE ADAPTER (Female ISO Tapered (BSPT) Threads to Tube End)

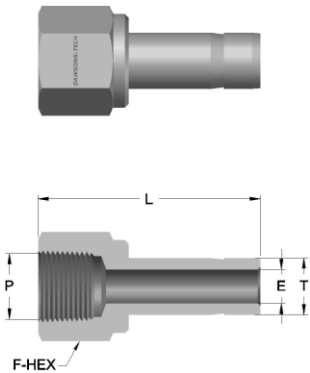

| Tube OD T | BSPT Thread Size P | Dimensions in mm | | F-Hex (Inch) | Dawsons-Tech Part No. |
|-------------------|--------------------------|------------------|------|-----------------|--------------------------|
| | | E | L | | |
| Fractional | | | | | |
| 1/4 | 1/8 | 4.1 | 33.0 | 9/16 | FA-4-2RT |
| 1/4 | 1/4 | 4.1 | 37.1 | 3/4 | FA-4-4RT |
| 3/8 | 1/4 | 6.9 | 38.1 | 3/4 | FA-6-4RT |
| 3/8 | 3/8 | 6.9 | 40.4 | 7/8 | FA-6-6RT |
| 1/2 | 1/4 | 8.8 | 43.7 | 3/4 | FA-8-4RT |
| 1/2 | 3/8 | 9.4 | 45.5 | 7/8 | FA-8-6RT |
| 1/2 | 1/2 | 8.8 | 52.3 | 1-1/16 | FA-8-8RT |
| Metric | | | | | |
| 6mm | 1/8 | 4.1 | 33.0 | 9/16 | FA-6M-2RT |
| 10mm | 1/4 | 6.9 | 38.1 | 3/4 | FA-10M-4RT |

Dimensions are for reference only and are subject to change.

FEMALE ADAPTER (Female ISO Parallel Threads (BSP) to Tube End)

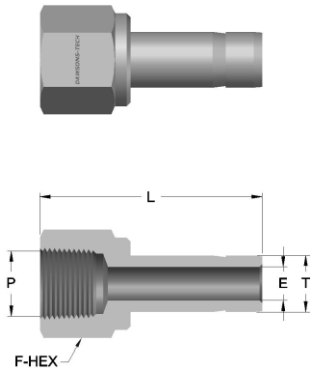

| Tube OD T | BSP Thread Size P | Dimensions in mm | | F-Hex (Inch) | Dawsons-Tech Part No. |
|-------------------|----------------------|------------------|------|--------------|-----------------------|
| | | E | L | | |
| Fractional | | | | | |
| 1/4 | 1/4 | 4.1 | 35.3 | 3/4 | FA-4-2RG |
| 3/8 | 3/8 | 6.6 | 39.4 | 7/8 | FA-6-6RG |
| 1/2 | 1/2 | 7.1 | 48.8 | 1-1/16 | FA-8-8RG |
| Metric | | | | | |
| 6mm | 1/4 | 4.1 | 35.3 | 3/4 | FA-6M-4RG |
| 6mm | 3/8 | 4.1 | 38.4 | 7/8 | FA-6M-6RG |
| 6mm | 1/2 | 4.1 | 42.9 | 1-1/16 | FA-6M-8RG |
| 8mm | 1/4 | 5.5 | 33.0 | 3/4 | FA-8M-4RG |
| 8mm | 1/2 | 5.6 | 43.7 | 1-1/16 | FA-8M-8RG |
| 10mm | 1/4 | 5.5 | 34.5 | 3/4 | FA-10M-4RG |
| 10mm | 1/2 | 7.1 | 41.1 | 1-1/16 | FA-10M-8RG |
| 12mm | 1/4 | 5.5 | 40.1 | 3/4 | FA-12M-4RG |
| 12mm | 1/2 | 7.1 | 48.8 | 1-1/16 | FA-12M-8RG |
| 16mm | 1/2 | 7.1 | 49.0 | 1-1/16 | FA-16M-8RG |
| 18mm | 1/2 | 7.1 | 49.3 | 1-1/16 | FA-18M-8RG |

Dimensions are for reference only and are subject to change.

MALE HOSE ADAPTER (Barb End to Male NPT End)

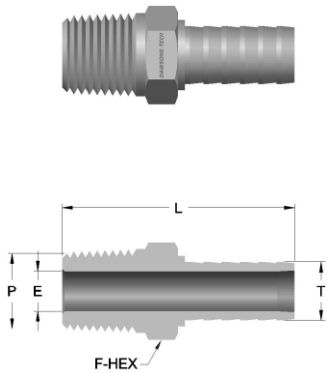

| Tube OD T | NPT Thread Size P | Dimensions in mm | | F-Hex (Inch) | Dawsons-Tech Part No. |
|--------------|----------------------|------------------|------|--------------|-----------------------|
| | | E | L | | |
| 1/8 | 1/8 | 2.0 | 27.4 | 7/16 | MHA-2-2N |
| 1/8 | 1/4 | 2.0 | 32.0 | 9/16 | MHA-2-4N |
| 3/16 | 1/8 | 3.0 | 32.3 | 7/16 | MHA-3-2N |
| 3/16 | 1/4 | 3.0 | 36.8 | 9/16 | MHA-3-4N |
| 1/4 | 1/8 | 4.8 | 37.3 | 7/16 | MHA-4-2N |
| 1/4 | 1/4 | 4.8 | 41.9 | 9/16 | MHA-4-4N |
| 1/4 | 3/8 | 4.8 | 42.2 | 11/16 | MHA-4-6N |
| 1/4 | 1/2 | 4.8 | 47.0 | 7/8 | MHA-4-8N |
| 5/16 | 1/8 | 4.8 | 39.4 | 7/16 | MHA-5-2N |
| 5/16 | 1/4 | 4.8 | 43.9 | 9/16 | MHA-5-4N |
| 5/16 | 1/8 | 4.8 | 44.2 | 7/16 | MHA-5-6N |
| 5/16 | 1/2 | 4.8 | 49.8 | 7/8 | MHA-5-8N |
| 3/8 | 1/4 | 7.6 | 43.9 | 9/16 | MHA-6-4N |
| 3/8 | 3/8 | 7.6 | 44.2 | 11/16 | MHA-6-6N |
| 3/8 | 1/2 | 7.6 | 49.8 | 7/8 | MHA-6-8N |
| 1/2 | 1/4 | 9.5 | 45.7 | 9/16 | MHA-8-4N |
| 1/2 | 3/8 | 9.5 | 46.0 | 11/16 | MHA-8-6N |
| 1/2 | 1/2 | 9.5 | 51.6 | 7/8 | MHA-8-8N |
| 5/8 | 1/2 | 11.9 | 52.6 | 7/8 | MHA-10-8N |
| 5/8 | 3/4 | 12.7 | 52.6 | 1-1/16 | MHA-10-12N |
| 3/4 | 1/2 | 16.0 | 54.4 | 7/8 | MHA-12-8N |
| 3/4 | 3/4 | 16.0 | 54.4 | 1-1/16 | MHA-12-12N |
| 3/4 | 1 | 16.2 | 61.7 | 1-3/8 | MHA-12-16N |
| 1 | 3/4 | 22.4 | 60.5 | 1-1/16 | MHA-16-12N |
| 1 | 1 | 22.4 | 65.3 | 1-3/8 | MHA-16-16N |

Dimensions are for reference only and are subject to change.

AN Male ADAPTER (AN Male Thread to The End)

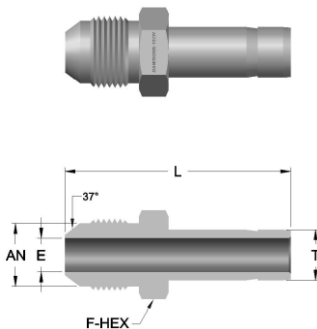

| Tube OD T | AN Tube Flare Size | Thread Size | Dimensions in mm | | F-Hex (Inch) | Dawsons-Tech Part No. |
|--------------|--------------------|-------------|------------------|------|--------------|-----------------------|
| | | | E | L | | |
| 1/4 | 1/4 | 7/16 x 20 | 4.3 | 37.1 | 1/2 | NMA-4-4AN |
| 3/8 | 1/4 | 7/16 x 20 | 4.3 | 38.9 | 1/2 | NMA-6-4AN |
| 3/8 | 3/8 | 9/16 x 18 | 6.9 | 39.6 | 5/8 | NMA-6-6AN |
| 1/2 | 1/2 | 3/4 x 16 | 9.4 | 48.5 | 13/16 | NMA-8-8AN |
| 3/4 | 3/4 | 1-1/16 x 12 | 14.7 | 56.1 | 1-1/8 | NMA-12-12AN |
| 1 | 1 | 1-5/16 x 12 | 20.3 | 65.5 | 1-3/8 | NMA-16-16AN |

Dimensions are for reference only and are subject to change.

TUBE to HOSE ADAPTER (Barb End to Tube End)

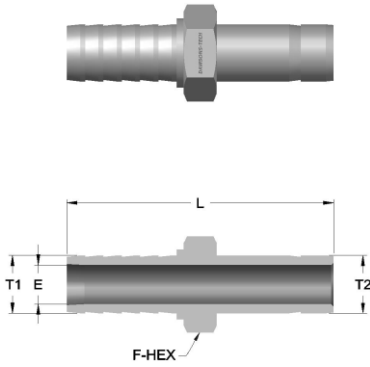

| Hose ID | Tube OD Size | Dimensions in mm | | F-Hex (Inch) | Dawsons-Tech Part No. |
|---------|--------------|------------------|------|--------------|-----------------------|
| | | E | L | | |
| 1/8 | 1/8 | 2.0 | 34.3 | 5/16 | THA-2-2 |
| 1/8 | 1/4 | 2.0 | 36.6 | 3/8 | THA-2-4 |
| 1/4 | 1/4 | 4.8 | 46.5 | 7/16 | THA-4-4 |
| 1/4 | 3/8 | 4.8 | 48.3 | 7/16 | THA-4-6 |
| 5/16 | 1/4 | 4.8 | 48.5 | 7/16 | THA-5-4 |
| 3/8 | 3/8 | 7.6 | 50.3 | 9/16 | THA-6-6 |
| 3/8 | 1/2 | 7.6 | 55.9 | 5/8 | THA-6-8 |
| 1/2 | 3/8 | 9.7 | 52.1 | 11/16 | THA-8-6 |
| 1/2 | 1/2 | 9.7 | 57.7 | 11/16 | THA-8-8 |
| 3/4 | 3/4 | 16.0 | 62.0 | 7/8 | THA-12-12 |

Dimensions are for reference only and are subject to change.

ORDERING INFORMATION

PRECISION THREADED PIPE FITTINGS

For Example : PART NO. : HN-8N-8RT-SS

| Type of Fittings | End Connection Pipe Thread Size & Type 1 | End Connection Pipe Thread Size & Type 2 | Material of Construction |
|------------------|--|--|--------------------------|
| HN | 8N | 8RT | SS |
| Hex Nipple | 1/2" NPT | 1/2" BSPT | SS316 |

SOCKET / BUTT WELD PIPE FITTINGS

For Example : PART NO. : MC-8TSW-8N-SS

| Type of Fittings | Tube OD | End Connection Pipe Thread Size & Type | Material of Construction |
|------------------|-----------------------|--|--------------------------|
| MC | 8TSW | 8N | SS |
| Male Connector | 1/2" Tube Socket Weld | 1/2" NPT | SS316 |

TUBE ADAPTERS

For Example : PART NO. : MA-8-8N-SS

| Type of Adapters | Tube OD | End Connection Pipe Thread Size & Type | Material of Construction |
|------------------|---------|--|--------------------------|
| AM | 8 | 8N | SS |
| Male Adapter | 1/2" | 1/2" NPT | SS316 |

Part No. Code Description :

| End Connection Pipe Thread Size | 2 | 1/8" |
|---------------------------------|----|-------|
| | 4 | 1/4" |
| | 6 | 3/8" |
| | 7 | 7/16" |
| | 8 | 1/2" |
| | 9 | 9/16" |
| | 10 | 5/8" |
| | 12 | 3/4" |
| | 14 | 7/8" |
| | 16 | 1" |

| End Connection Thread Type | N : NPT |
|----------------------------|---|
| | RT : BSPT |
| | RP : BSP (Male) |
| | RG : BSP (Female) |
| | SAE : Straight Thread |
| | ED : BSP (Male) (With Elastic Sealing) |
| | TSW : Tube Socket Weld |
| | TBW : Tube Butt Weld |
| | PSW : Pipe Socket Weld |
| | PBW : Pipe Butt Weld |

| Tube OD Size | | | |
|--------------|-------|--------|------|
| Fractional | | Metric | |
| 2 | 1/8" | 6M | 6mm |
| 3 | 3/16" | 8M | 8mm |
| 4 | 1/4" | 10M | 10mm |
| 5 | 5/16" | 12M | 12mm |
| 6 | 3/8" | 16M | 16mm |
| 8 | 1/2" | 18M | 18mm |
| 10 | 5/8" | | |
| 12 | 3/4" | | |
| 16 | 1" | | |

| Material of Construction | SS : SS316 |
|--------------------------|-------------------------|
| | SSL : SS316L |
| | Duplex : D |
| | Monel : M |
| | Inconel 625 : I6 |
| Inconel 825 : I8 | |



Fueling Products



Twin Ferrule Compression Tube Fittings



Tube Fittings for Pressure Rating 15000 PSIG



37° FLARE FITTINGS



Quick Connect Coupling



2 Way Ball Valves



3 Way Trunnion Ball Valves



Check Valves

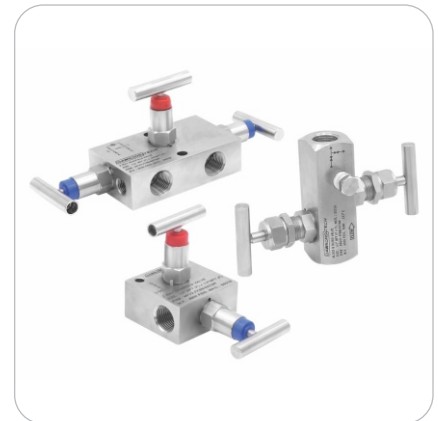

2 / 3 Way Manifold / Block & Bleed Valves



Relief Valves



CNG Receptacles
Series : DTLR01 & DTLR03





CNG Receptacles
Series : DTSR05 & DTSR07



Registered Office and Manufacturing Plant :

DAWSONS-TECH COMPONENTS LLP

 Unit No. DD - 6 & 7, Khan Real Industrial Estate,
N. H. 08, Pelhar, Vasai Phata, Vasai (East),
Dist. Palghar - 401 208, Maharashtra, India.
LLPIN: AAN-0434

 Mobile : +91-9833355596

 Email : info@dawsonstech.com

 Website: www.dawsonstech.com