

DAWSONS-TECH[®]

OVER 35 YEARS OF EXPERIENCE



**CATALOGUE NO.
TF-21**

INSTRUMENTATION / CNG TUBE FITTINGS

www.dawsonstech.com

THE COMPANY :

DAWSONS-TECH® is an ISO 9001:2015 certified manufacturing company offers wide range of **Consistent, Reliable and Superior Quality** High Pressure Instrumentation / CNG / Hydrogen Products used in Vehicles, Fueling Equipments like CNG Cascades, CNG Dispensers, Booster Compressors, Online Compressors, Decompression Skid, LCV Filling Post, Meter Regulation Skids, Pressure Regulation Skids, etc.



dedicated team of employees in place. This facilitate us to design and manufacture our product range under stringent quality checks and measurements that ensures **"A TOTAL CUSTOMER SATISFACTIONS"**.

QUALITY :

DAWSONS-TECH® pursues not only performance of its products but also ensures **"TOTAL QUALITY CONTROL MANAGEMENT SYSTEMS IN ACCORDANCE WITH ISO 9001:2015"** which is achieved by alerting and educating each and every employee, the importance of quality and by implementing the quality control procedures at every stage of production to final inspection from incoming raw material to finish products.

MANUFACTURING :

DAWSONS-TECH® established its comprehensive state of art manufacturing and testing facility installing various CNC Turning Centre and CNC Turnmill Centre, Vertical Machining Centre, etc. with the highly motivated and

 OUR CAPABILITIES	 CERTIFICATIONS	 BENEFITS
<ul style="list-style-type: none"> • Over 35 Years of Experience • Excellent Technical Knowledge • Latest Design Equipment's & Software • Modern Manufacturing Facilities • Highly Motivated Team of Employees • Excellent Inspection Facilities • Product Performance Testing Facilities 	<ul style="list-style-type: none"> • ISO 9001-2015 • ISO 14001-2015 • ISO 45001-2018 • PED 2014/68/EU • ASTM F1387-19 • MSS SP-99-2016a • Helium Leak Test • Hydro Static Proof Test • Pneumatic Proof Test 	<ul style="list-style-type: none"> • High Quality • Proven Design for Leak Free Connections • Effective Operations • High Efficiency • Prompt Reply • Maximum Flexibility • Maximum Safety in Operation • Substantial Cost Saving





RESEARCH & DEVELOPMENT :

With our extensive experience, expertise and continues Research & Development with incorporation of advanced technology and high-tech cutting-edge machineries, **DAWSONS-TECH®** is committed to constant upgradation and expand its product range to meet the requirements of its customer to their entire satisfaction at every time.

CUSTOMER SATISFACTION :

We strive to achieve total customer satisfaction and continuously work to set higher goals to provide the reliable quality, timely delivery of our products and prompt services in the best interest of our customers with **Very Competitive Price**.

OUR MISSION

 RESPONSIBILITY	 RELIABILITY	 ENVIRONMENTAL AWARENESS	 TECHNICAL EXPERTISE	 INNOVATIVE TECHNOLOGY	 DEVELOPMENT	 CUTTING EDGE SOLUTIONS	 TOTAL CUSTOMER SATISFACTION
---	---	---	---	---	--	--	---

Features & Benefits of DAWSONS-TECH Twin Ferrule Tube Fittings.



Dawsons-Tech Twin Ferrule Tube Fittings have been carefully designed & manufactured under strict quality assurance procedures meeting the requirements of ISO 9001-2015 & PED 2014/68 EU.

Back Ferrules are Case Hardened having average hardness 1000 HV which ensure Strong Tube Grip, Excellent Vibration Resistance, Leak Free Gas Seal, Maximum Reliability and safety under high pressure, vibration and Deep Vacuum Applications

Front Ferrules are very precisely machined to very close tolerances which ensure leak free connection between Tube and Body

Pipe Threads are manufactured to maximum tolerances to have robust and safe connection

Seamless Tube

Internally Silver Plated **Compression Nut** Reduce the torque during the assembly and Extend the Fittings life by preventing galling across wide range of temperature.

The thread UNF / UNEF at compression end of Tube Fittings are **Cold Rolled** which ensures High Thread Strength, Highest Thread Surface quality, Greater accuracy and resistance to fatigue and superior wear resistance.

Sizing angle is provided at the base of the Tube Socket in the **Fitting Body** to align the Tube while installation & also reduce the possibility of sticking of tube in the body during assembly

SS316 / 316L Material is **Heat / Lot Code** traceable to ensure safety capabilities with increased effectiveness

Feature's & Comparison of Twin Ferrule Tube Fittings :

FEATURES	DAWSONS-TECH® VS. SWAGELOK®
Twin Ferrule Design	Yes
Traceable Quality SS316	Yes
UNF / UNEF Threads are Cold Rolled	Yes
Silver Plated & Dry Lubricated Nut	Yes
Low Torque assembly	Yes
Case Hardened Back Ferrule	Yes
Thread Design to allow intermix of Components	Same
Shoulder Marking to distinguish between Metric & Imperial size	Same
Ability to Identity different thread forms through body marking	Same
Stringent Quality Assurance Standard	Yes
Installation procedures	Same
Gaugeability to check correct installation	Same
Pressure Rating upto 10,000 PSIG (690 bar)	Same
Temperature Rating upto 538° C	Same
Requirement of Tube Specifications	Same
Leak integrity	Same

DAWSONS-TECH SS316 Twin Ferrule Tube Fittings have been satisfactorily type tested to ASTM F1387-19 Standard specifications for performance of Piping & Tubing mechanical attached Fittings.

The details of test carried out under witness of M/s. TUV Rheinland are as under :

- | | |
|---|-------------------|
| • Examination of Test Specimen | - Annex : A2 |
| • Pneumatic Proof Test | - Annex : A3 |
| • Hydrostatic Proof Test | - Annex : A4 |
| • Impulse Test & Repeated Assembly Test | - Annex : A5 & A9 |
| • Flexure Fatigue Test & Repeated Assembly Test | - Annex : A6 & A9 |
| • Tensile Test | - Annex : A7 |
| • Hydrostatic Burst Test | - Annex : A8 |
| • Rotary Flex Test | - Annex : A10 |
| • Thermal Cycling Test | - Annex : S2 |
| • Elevated Temperature Soak Test | - Annex : S3 |
| • Vibration Test | - Annex : S8 |

INTERMIX & INTERCHANGE TEST

DAWSONS-TECH Twin Ferrule Tube Fittings have been intermix & Interchange tested with Swagelok® Tube Fittings.

Following performance test carried out satisfactorily :

- | | |
|--------------------------|--------------|
| • Pneumatic Proof Test | - Annex : A3 |
| • Hydrostatic Proof Test | - Annex : A4 |
| • Hydrostatic Burst Test | - Annex : A8 |

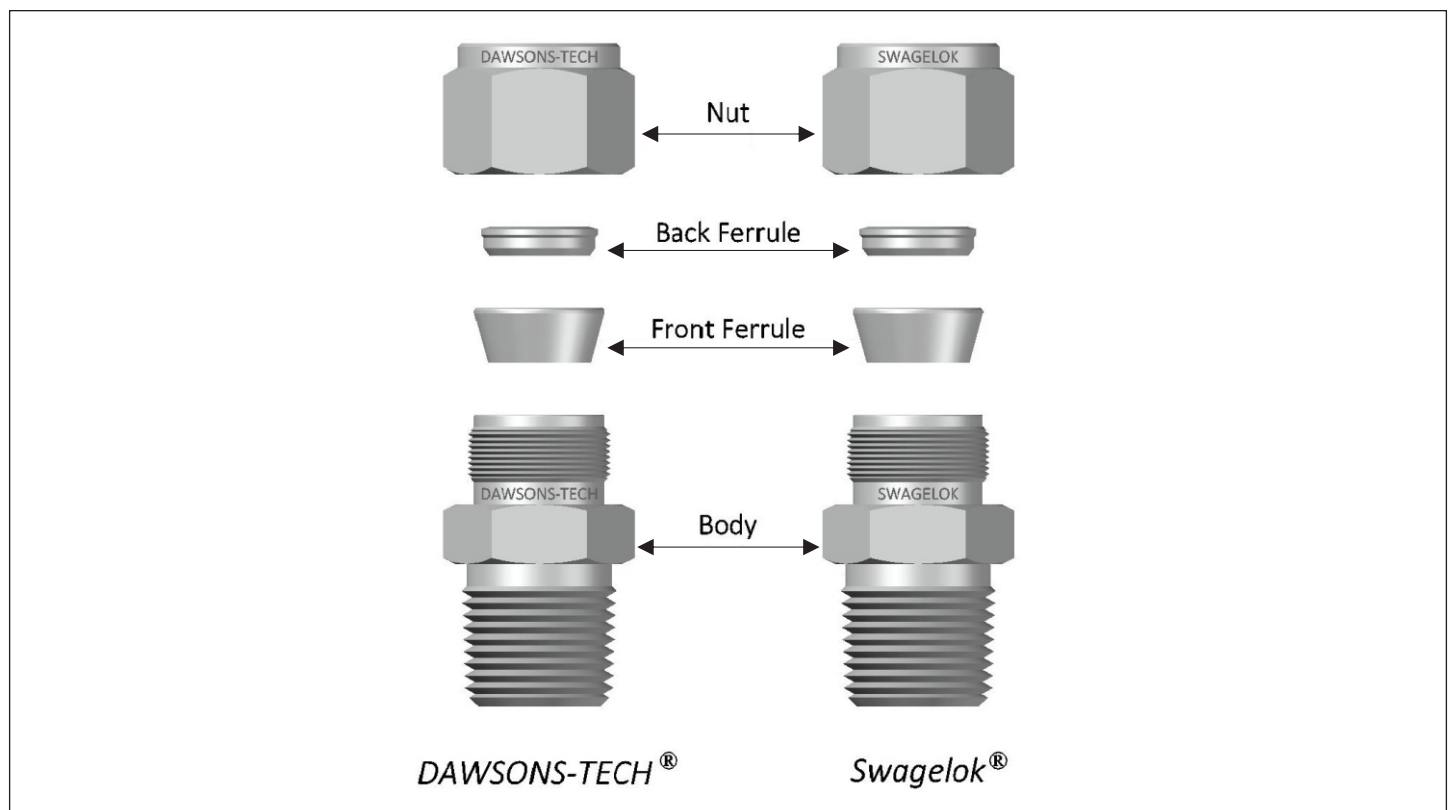

Materials :

DAWSONS-TECH Twin Ferrule Tube Fittings are offered in various materials to meet the requirements of various applications including Petrochemical, Oil & Gas, Semiconductor, Power, Nuclear, CNG and other major Industries.

Material	Bar Stock	Forging
Stainless Steel	ASTM A479 Type 316 ASME SA479 Type 316 JIS G4303	ASTM A182 ASME SA182 JIS G3214
Brass	ASTM B16 UNS C36000 ASTM B453 UNS C35300 JIS H3250 Alloy C3604	ASTM B283 Alloy 37700 JIS H3250 Alloy C3771
Carbon Steel	ASTM A276 S31803 JIS G4051 S20C - S48C	ASTM A105 JIS G4051 S20C - S48C
Duplex	ASTM A276 S31803 ASTM A479 S31803	ASTM A182 F51
Super Duplex	ASTM A479 S32750	ASTM A182 F51
Alloy 20	ASTM B473 UNS N08020	ASTM B462 UNS N08020
Alloy 400	ASTM B164 UNS N04400	ASTM B564 N04400
Alloy 625	ASTM B446 UNS N06625	ASTM B565 UNS N06625
Alloy 825	ASTM B425 UNS N08825	ASTM B564 UNS N08825

Note : DAWSONS-TECH Steel Fittings are White Zinc Plated. Every Carbon Steel Fittings are supplied with SS316 Front & Back Ferrules.

Cleaning : Each and every components of DAWSONS-TECH Tube Fittings are cleaned by Ultra Sonic Cleaning process with D.I. Water to remove all surface contaminations.

Temperature Rating : DAWSONS-TECH Twin Ferrule Tube Fittings are performed satisfactorily under following temperature rating :

Material	Temperature Rating
Stainless Steel 316	-190° C to 538° C (-321° F to 1000° F)
Brass	-54° C to 204° C (-65° F to 400° F)
Monel	-54° C to 427° C (-65° F to 800° F)

Temperature Derating : The working pressure varies with temperature. The working pressure at different temperature can be selected by the temperature derating factor in the table shown below.

Temperature	Temperature Derating Factor			
	SS316	SS304	Copper	Monel 400
37° C (100° F)	1.00	1.00	1.00	1.00
93° C (200° F)	1.00	1.00	0.80	0.88
149° C (300° F)	1.00	1.00	0.78	0.82
204° C (400° F)	0.96	0.94	0.50	0.79
260° C (500° F)	0.90	0.88	-	0.79
315° C (600° F)	0.85	0.82	-	0.79
371° C (700° F)	0.82	0.80	-	0.76
427° C (800° F)	0.79	0.76	-	0.76
482° C (900° F)	0.78	0.73	-	-
538° C (1000° F)	0.76	0.69	-	-

Pressure Rating calculated based on temperature derating factor :

- Selected SS316 Seamless Tube Size : 1/2" OD x 0.065" wall at temperature 427° C
- Working Pressure of the above Tubing at ambient temperature : 5100 PSI
- Temperature derating factor at 427° C = 0.79
- The working pressure at temperature 427° C = 0.79 x 5100 = 4029 PSI

DAWSONS-TECH Twin Ferrule Tube Fittings consists of Compression Nut, Back Ferrule, Front Ferrule & Body. This mechanisms are used for sealing and gripping the Tubing with Fittings Body to have Leak Free assembly.

To assemble, insert the Tube into the Fitting assembly resting it firmly on the internal shoulder of the Fittings Body, Finger Tight the Nut, Tighten the Nut 1-1/4 turn from the Finger Tight position. During tightening, the Compression Nut, the Back Ferrule and the Front Ferrule moves forward between the Nut and Fitting Body using the mechanical force created by tightening the Nut clockwise. The Back Ferrule id driven against the tapered rear of the Front Ferrule and the Front Ferrule is driven by force into the tapered surface of the Body.

The Back Ferrule is Swaged radially inwards on the Tube while pushing the Front Ferrule on tapered surface of the Body to achieve full face seal. This ensures leak free effective sealing connection against high pressure of Gas / Fluid, Ultra High Vacuum, Impulse, Thermal Shock, Vibration and many other stringent applications.

Construction of Twin Ferrule Tube Fittings

Twin Ferrule Tube Fittings consist of four precision components such as Nut, Back Ferrule, Front Ferrule & Body.

Fraction Twin Ferrule Tube Fittings

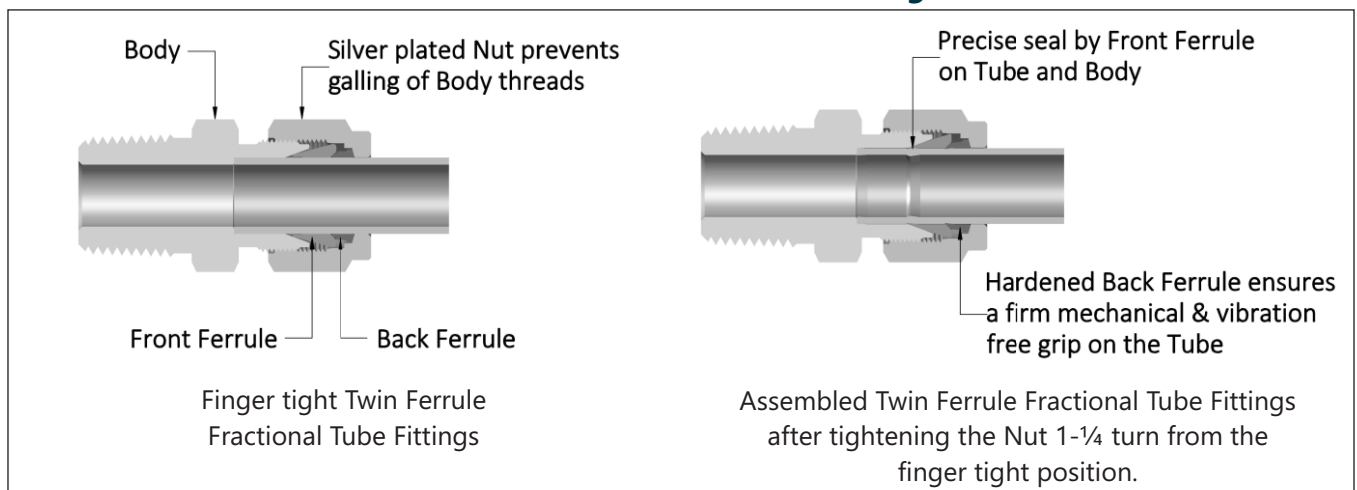

Metric Twin Ferrule Tube Fittings

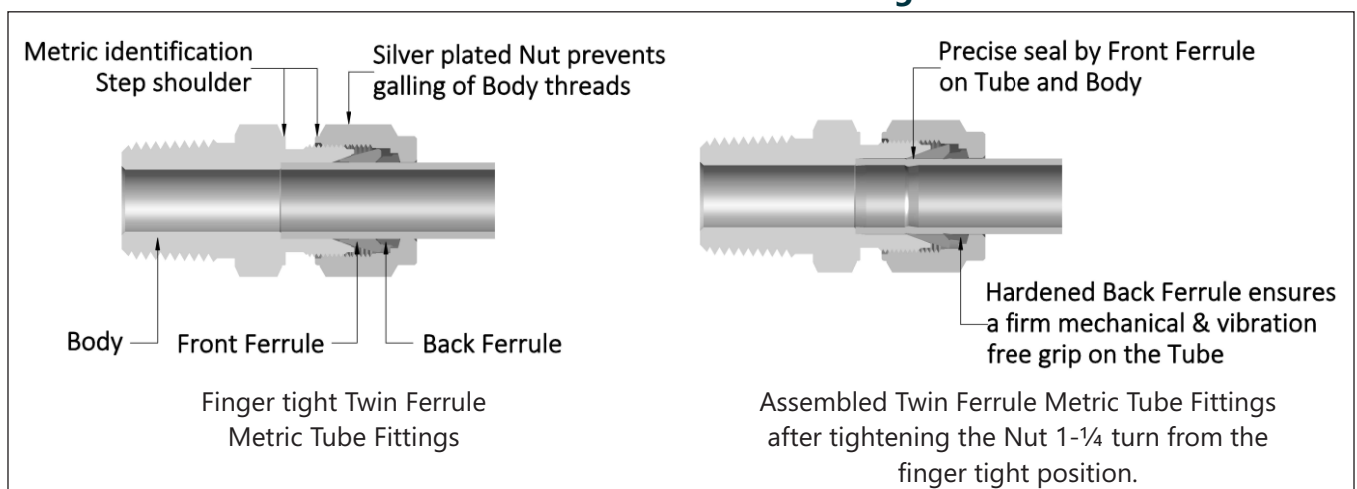

Guageability :

DAWSONS-TECH Twin Ferrule Tube Fittings are manufactured to very stringent tolerances to meet the guageability to check the gap between the Nut and the Body Hex. This allows easy inspection for sufficient tightening of the Nut before a system is pressurized, which ensures maximum safety and reliability.

DAWSONS-TECH Twin Ferrule Tube Fittings provide best performance with good quality Tubing.

- The Tube must be reasonably round.
- The surface of the Tube must be free from scratches, draw mark and must have good finish.
- The recommended hardness of the Tubing should be 80 HRB or less.
- The Tubing material must be compatible with process Fluid / Gas.
- The ends of the Tube must be free from burrs and squarely cut.

Tube Cutting :

The Tubes can be cut by two methods to avoid deformation Tube Cutter.

- To attain a leak free connection, the Tubing must be cut squarely with good quality cutter.
- After cutting the Tube, both ends of the Tube must be deburred properly to avoid the damage to the Tube Fittings.

Hacksaw Cutting :

- The Tube must be cut with guide block to get square ends.
- After cutting the Tube, both ends of the Tube must be deburred properly to avoid the damage to the Tube Fittings.

Maximum Allowable Working Pressure :

- Working pressure calculated in accordance with ASME B31.3, Chemical Plant and Petrochemical Refinery Piping Code, 2002 edition.

Stainless Steel Tubing (Inch) :

Fully annealed SS304 & SS316 High Quality Seamless Stainless Steel Tube to ASTM A269 or equivalent

Stainless Steel Tube								
Tube OD (Inch)	Tube Wall Thickness in Inch							
	0.028	0.035	0.049	0.065	0.083	0.095	0.109	0.120
1/8	8,500	11,200	–	–	–	–	–	–
3/16	5,400	7,000	10,400	–	–	–	–	–
1/4	4,000	5,100	7,500	10,400	–	–	–	–
5/16	–	4,000	5,800	8,000	–	–	–	–
3/8	–	3,300	4,800	6,500	–	–	–	–
1/2	–	2,600	3,700	5,100	6,700	–	–	–
5/8	–	–	2,900	4,000	5,200	6,000	–	–
3/4	–	–	2,400	3,300	4,200	4,900	5,800	–
7/8	–	–	2,000	2,800	3,600	4,200	4,800	–
1	–	–	–	2,400	3,100	3,600	4,200	4,700

Note :

- 1) For Gas Service, applying Tube wall thickness only on outside of highlighted area.
- 2) Pressure rating in PSIG.

Stainless Steel Tubing (Metric) :

Fully annealed SS304 & SS316 High Quality Seamless Stainless Steel Tube to ASTM A269 or equivalent

Stainless Steel Tube										
Tube OD (Inch)	Tube Wall Thickness in mm									
	0.8	1	1.2	1.5	1.8	2	2.2	2.5	2.8	3
3	720	950	–	–	–	–	–	–	–	–
4	520	670	840	–	–	–	–	–	–	–
6	330	430	520	680	–	–	–	–	–	–
8	–	310	380	490	–	–	–	–	–	–
10	–	240	300	380	470	530	–	–	–	–
12	–	200	240	310	380	430	–	–	–	–
14	–	180	220	280	340	390	430	–	–	–
15	–	170	200	260	320	360	400	–	–	–
16	–	–	190	240	300	330	370	430	–	–
18	–	–	170	2140	260	290	330	380	–	–
20	–	–	150	190	230	260	290	330	380	–
22	–	–	140	170	210	240	260	300	340	–
25	–	–	–	150	180	200	230	260	300	320

Note :

- 1) For Gas Service, applying Tube wall thickness only on outside of shade boundary.
- 2) Pressure rating in BAR.

- Allowable stress of 20,000 PSI (1379 Bar) between -29° C and 37° C (-20° F and 100° F) based on ultimate Tensile Strength 75,000 PSI (5171 Bar).
- Base on minimum wall thickness and maximum O.D. allowable by ASTM A269
- For Welded Tubing, the following derating rate to be applied for Weld integrity. (ASME B31.1 - 2002 Edition)

For Double Welded Tubing : 0.85
 For Single Welded Tubing : 0.80

Note :

1. All calculations are based on maximum outside diameter and minimum wall thickness without allowance for corrosion and erosion.
2. Care should be taken for temperature rating if Tubing is Coated or Plated.
3. Figures shown are not for design purpose but for reference only and the accuracy of information here is not liability of our company.

Monel 400 Tubing (Inch) :

Fully annealed Seamless Monel 400 to ASTM B165 or equivalent. Hardness : RB 75 or less.

Monel 400 Tube								
Tube OD (Inch)	Tube Wall Thickness in Inch							
	0.028	0.035	0.049	0.065	0.083	0.095	0.109	0.120
1/8	7,900	10,100	–	–	–	–	–	–
1/4	3,700	4,800	7,000	9,500	–	–	–	–
3/8	–	3,100	4,400	6,100	–	–	–	–
1/2	–	2,300	3,200	4,400	–	–	–	–
3/4	–	–	2,200	3,000	4,000	4,600	–	–
1	–	–	–	2,200	2,900	2,900	3,900	4,300

Note :

- 1) For Gas Service, applying Tube wall thickness only on outside of shade boundary.
- 2) Pressure rating in PSIG.

Copper Tubing (Inch) :

High quality soft annealed Seamless Copper Tube to ASTM B - 75 or equivalent.
Hardness : Rockwell 15T 60 or less.

Copper Tube								
Tube OD (Inch)	Tube Wall Thickness in Inch							
	0.028	0.035	0.049	0.065	0.083	0.095	0.109	0.120
1/8	2,804	3,787	–	–	–	–	–	–
3/16	1,810	2,343	3,615	–	–	–	–	–
1/4	1,321	1,696	2,565	3,639	–	–	–	–
5/16	–	1,329	1,988	2,782	–	–	–	–
3/8	–	1,093	1,623	2,251	–	–	–	–
1/2	–	806	1,187	1,630	2,160	–	–	–
5/8	–	–	935	1,277	1,681	1,970	–	–
3/4	–	–	748	1,017	1,332	1,555	1,823	–
7/8	–	–	369	867	1,133	1,320	1,544	–
1	–	–	559	756	986	1,147	1,339	1,479

Note : Pressure rating in PSIG.

Copper Tubing (Metric) :

Copper Tube										
Tube OD (Inch)	Tube Wall Thickness in mm									
	0.8	1	1.2	1.5	1.8	2	2.2	2.5	2.8	3
3	239	326	–	–	–	–	–	–	–	–
4	175	228	291	–	–	–	–	–	–	–
6	111	142	178	237	299	–	–	–	–	–
8	81	103	128	168	210	–	–	–	–	–
10	64	81	100	131	162	184	–	–	–	–
12	53	67	82	107	131	149	–	–	–	–
14	–	57	70	90	111	125	139	162	–	–
15	–	53	65	84	102	116	129	150	–	–
16	–	49	61	78	96	108	120	139	–	–
18	–	43	53	68	83	94	104	121	138	150
20	–	39	47	61	75	84	93	107	123	133
22	–	35	43	55	67	76	84	97	110	120
25	–	31	38	48	59	66	73	84	96	104

Note : Pressure rating in BAR.

- Allowable stress of 6,000 PSI (413 Bar) between -29° C and 37° C (-20° F and 100° F) based on ultimate Tensile Strength 30,000 PSI (2068 Bar).
- Base on minimum wall thickness and maximum O.D. allowable by ASTM B75.

Ordering Information : DAWSONS-TECH material description











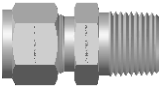
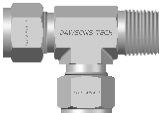







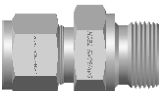

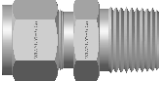
Material Grade	Code	Material Grade	Code
SS316	SS	Alloy - 20	A20
Brass	B	Alloy - 400	A400
Carbon Steel	CS	Alloy - 625	A625
Duplex	D	Alloy - 825	A825
Super Duplex	SD		

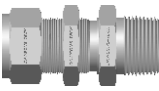
Example : Item : Male Connector, Size : 1/4" ODT x 1/4" NPT (Male)

Part No. : DTMC-4-4N, Selected Material : SS316

SS316 Material Code : SS, Ordering Part No. : DTMC-4-4N/SS

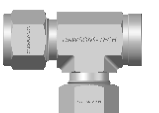
Note : While Ordering, Suffix material code along with Fittings Part No. as shown above.

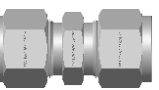
 <p>Male Connector Fractional / Metric Tube to</p> <ul style="list-style-type: none"> • Male NPT Thread 12 & 13 • Male ISO BSP Taper (RT) Thread 14 & 15 	 <p>Male Run Tee Fractional / Metric Tube to</p> <ul style="list-style-type: none"> • Male NPT Thread 30
 <p>Male Connector Fractional Tube to</p> <ul style="list-style-type: none"> • Male SAE / MS Straight Thread 16 	 <p>Posisable Male Branch Tee Fractional Tube to</p> <ul style="list-style-type: none"> • Male SAE / MS Straight Thread 31
 <p>Male Connector Fractional / Metric Tube to</p> <ul style="list-style-type: none"> • Male SAE / MS Straight Thread 17 	 <p>Posisable Male Branch Tee Fractional Tube to</p> <ul style="list-style-type: none"> • Male ISO Parallel (PR) Thread 31 & 32
 <p>Male Connector Fractional / Metric Tube to</p> <ul style="list-style-type: none"> • Male EO Seal Straight Thread 17 • Male EO Seal ISO Parallel Thread 18 	 <p>Posisable Male Run Tee Fractional / Metric Tube to</p> <ul style="list-style-type: none"> • Male ISO Straight Thread 32
 <p>Male Connector Fractional / Metric Tube to</p> <ul style="list-style-type: none"> • Male ISO Parallel (RP) Thread 19 	 <p>Positionable Male Run Tee Fractional / Metric Tube to</p> <ul style="list-style-type: none"> • Male ISO Parallel (PR) Thread 33
 <p>Male Connector Fractional / Metric Tube to</p> <ul style="list-style-type: none"> • Male ISO Parallel (RS) Thread 20 & 21 	 <p>Female Connector Fractional / Metric Tube to</p> <ul style="list-style-type: none"> • Female NPT Thread 34 & 35 • Male ISO BSP Taper (RT) Thread 36
 <p>Thermocouple Male Connector Fractional Tube to</p> <ul style="list-style-type: none"> • Male NPT Thread 22 	 <p>Female Connector Fractional / Metric Tube to</p> <ul style="list-style-type: none"> • Male ISO Parallel (RG) Thread 37
 <p>Bulkhead Male Connector Fractional / Metric Tube to</p> <ul style="list-style-type: none"> • Male NPT Thread 23 	 <p>Bulkhead Female Connector Fractional / Metric Tube to</p> <ul style="list-style-type: none"> • Female NPT Thread 38
 <p>Male Elbow Fractional / Metric Tube to</p> <ul style="list-style-type: none"> • Male NPT Thread 24 & 25 • Male ISO BSP Taper (RT) Thread 26 	 <p>Female Elbow Fractional / Metric Tube to</p> <ul style="list-style-type: none"> • Female NPT Thread 39
 <p>Posisable Male Elbow Fractional / Metric Tube to</p> <ul style="list-style-type: none"> • Male SAE / MS Straight Thread 27 	 <p>Female Branch Tee Fractional / Metric Tube to</p> <ul style="list-style-type: none"> • Female NPT Thread 40
 <p>Posisable Male Elbow Fractional / Metric Tube to</p> <ul style="list-style-type: none"> • Male ISO Parallel (PR) Thread 27 & 28 	 <p>Female Run Tee Fractional / Metric Tube to</p> <ul style="list-style-type: none"> • Female NPT Thread 41
 <p>Male Branch Tee Fractional / Metric Tube to</p> <ul style="list-style-type: none"> • Male NPT Thread 29 	 <p>Union</p> <ul style="list-style-type: none"> • Fractional & Metric Tube 42 • Metric to Fractional Tube 43

	Reducing Union • Fractional & Metric Tube	44		Male Pipe Weld Connector • Fractional & Metric Tube to Male Pipe Thread	53 & 54
	Bulkhead Union Fractional & Metric Tube	45		Male Pipe Weld Elbow • Fractional Tube to Male Male Pipe Weld	54
	Bulkhead Reducing Union • Fractional Tube	46		Reducer • Fractional Tube to Fractional Ports 55 • Metric Tube to Metric Ports 56 • Metric Tube to Fractional Ports 57	
	Union Elbow • Fractional & Metric Tube	46 & 47		Bulkhead Reducer • Fractional Tube & Fractional Ports	57
	Reducing Union Elbow • Fractional Tube	48		Port Connector • Fractional & Metric Ports	58
	Union Tee • Fractional & Metric Tube	49		Reducing Port Connector • Fractional & Metric Ports	59
	Reducing Union Tee • Fractional Tube	50		Cap • Fractional & Metric Tube	60
	Union Cross • Fractional & Metric Tube	51 & 51		Plug • Fractional & Metric Tube	61
	AN Union • Fractional to Flared Tube	51		Nut • Fractional & Metric Tube	62
	Bulkhead AN Union • Fractional to Flared Tube	52		Front Ferrule • Fractional & Metric Tube	63
	Tube Socket Weld Union • Fractional Tube	52		Back Ferrule • Fractional & Metric Tube	63
	Tube Socket Weld Elbow • Fractional Tube	53		Bulkhead Lock Nut • Fractional & Metric Tube	64

Male Connector (*Fractional* Tube to NPT Male Thread)

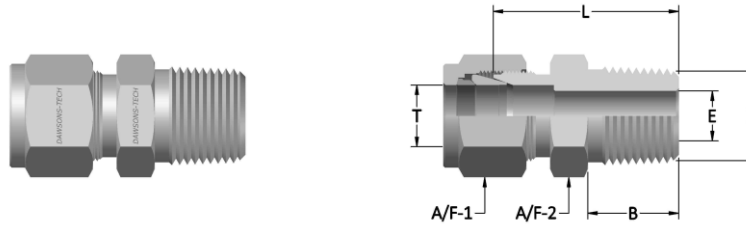

STANDARD CONFIGURATION DIMENSIONS

Tube OD	NPT Male Thread	Dimension in Inch					Dawsons-Tech Part No.
T	P	B	E	L	A/F1	A/F2	
1/8	1/8	0.38	0.09	0.94	7/16	7/16	DTMC-2-2N
1/8	1/4	0.56	0.09	1.14	7/16	9/16	DTMC-2-4N
1/8	3/8	0.56	0.09	1.15	7/16	11/16	DTMC-2-6N
1/8	1/2	0.75	0.09	1.40	7/16	7/8	DTMC-2-8N
3/16	1/8	0.38	0.12	0.97	1/2	7/16	DTMC-3-2N
3/16	1/4	0.56	0.12	1.17	1/2	9/16	DTMC-3-4N
1/4	1/8	0.38	0.19	1.00	9/16	1/2	DTMC-4-2N
1/4	1/4	0.56	0.19	1.20	9/16	9/16	DTMC-4-4N
1/4	3/8	0.56	0.19	1.22	9/16	11/16	DTMC-4-6N
1/4	1/2	0.75	0.19	1.47	9/16	7/8	DTMC-4-8N
1/4	3/4	0.75	0.19	1.53	9/16	1-1/16	DTMC-4-12N
5/16	1/8	0.38	0.19	1.05	5/8	9/16	DTMC-5-2N
5/16	1/4	0.56	0.25	1.23	5/8	9/16	DTMC-5-4N
5/16	3/8	0.56	0.25	1.25	5/8	11/16	DTMC-5-6N
5/16	1/2	0.75	0.25	1.50	5/8	7/8	DTMC-5-8N
3/8	1/8	0.38	0.19	1.10	11/16	5/8	DTMC-6-2N
3/8	1/4	0.56	0.28	1.28	11/16	5/8	DTMC-6-4N
3/8	3/8	0.56	0.28	1.28	11/16	11/16	DTMC-6-6N
3/8	1/2	0.75	0.28	1.53	11/16	7/8	DTMC-6-8N
3/8	3/4	0.75	0.28	1.59	11/16	1-1/16	DTMC-6-12N
1/2	1/8	0.38	0.19	1.13	7/8	13/16	DTMC-8-2N
1/2	1/4	0.56	0.28	1.31	7/8	13/16	DTMC-8-4N
1/2	3/8	0.56	0.38	1.31	7/8	13/16	DTMC-8-6N
1/2	1/2	0.75	0.41	1.53	7/8	7/8	DTMC-8-8N
1/2	3/4	0.75	0.41	1.59	7/8	1-1/16	DTMC-8-12N
1/2	1	0.94	0.41	1.85	7/8	1-3/8	DTMC-8-16N
5/8	3/8	0.56	0.38	1.34	1	15/16	DTMC-10-6N
5/8	1/2	0.75	0.47	1.53	1	15/16	DTMC-10-8N
5/8	3/4	0.75	0.50	1.59	1	1-1/8	DTMC-10-12N
3/4	1/2	0.75	0.47	1.59	1-1/8	1-1/16	DTMC-12-8N
3/4	3/4	0.75	0.62	1.59	1-1/8	1-1/16	DTMC-12-12N
3/4	1	0.94	0.62	1.85	1-1/8	1-3/8	DTMC-12-16N
7/8	3/4	0.75	0.62	1.59	1-1/4	1-3/16	DTMC-14-12N
7/8	1	0.94	0.72	1.85	1-1/4	1-3/8	DTMC-14-16N
1	1/2	0.75	0.47	1.78	1-1/2	1-3/8	DTMC-16-8N
1	3/4	0.75	0.62	1.78	1-1/2	1-3/8	DTMC-16-12N
1	1	0.94	0.88	1.97	1-1/2	1-3/8	DTMC-16-16N

Dimensions are for reference only and are subject to change

Male Connector (*Metric* Tube to NPT Male Thread)

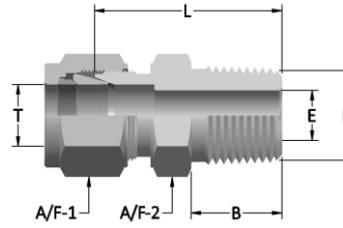
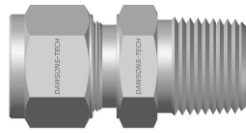

STANDARD CONFIGURATION DIMENSIONS

Tube OD	NPT Male Thread	Dimension in mm			A/F1	A/F2	Dawsons-Tech Part No.
		T	P	B			
3	1/8	9.7	2.4	23.9	7/16	7/16	DTMC-3M-2N
3	1/4	14.3	2.4	29.0	7/16	9/16	DTMC-3M-4N
4	1/8	9.7	2.4	24.6	1/2	7/16	DTMC-4M-2N
4	1/4	14.3	2.4	29.7	1/2	9/16	DTMC-4M-4N
6	1/8	9.7	4.8	25.4	9/16	9/16	DTMC-6M-2N
6	1/4	14.3	4.8	30.5	9/16	9/16	DTMC-6M-4N
6	3/8	14.3	4.8	31.0	9/16	11/16	DTMC-6M-6N
6	1/2	19.0	4.8	37.3	9/16	7/8	DTMC-6M-8N
8	1/8	9.7	4.8	26.7	5/8	9/16	DTMC-8M-2N
8	1/4	14.3	6.4	31.2	5/8	9/16	DTMC-8M-4N
8	3/8	14.3	6.4	31.8	5/8	11/16	DTMC-8M-6N
8	1/2	19.0	6.4	38.1	5/8	7/8	DTMC-8M-8N
10	1/8	9.7	4.8	28.7	3/4	11/16	DTMC-10M-2N
10	1/4	14.3	7.9	33.3	3/4	11/16	DTMC-10M-4N
10	3/8	14.3	7.9	33.3	3/4	11/16	DTMC-10M-6N
10	1/2	19.0	7.9	38.9	3/4	7/8	DTMC-10M-8N
10	3/4	19.0	7.9	40.4	3/4	1-1/16	DTMC-10M-12N
12	1/8	9.7	4.8	28.7	7/8	13/16	DTMC-12M-2N
12	1/4	14.3	7.1	33.3	7/8	13/16	DTMC-12M-4N
12	3/8	14.3	9.5	33.3	7/8	13/16	DTMC-12M-6N
12	1/2	19.0	9.5	38.9	7/8	7/8	DTMC-12M-8N
12	3/4	19.0	9.5	40.4	7/8	1-1/16	DTMC-12M-12N
14	1/4	14.3	7.1	34.0	1	15/16	DTMC-14M-6N
14	3/8	19.0	9.5	34.0	1	15/16	DTMC-14M-8N
14	1/2	19.0	11.1	38.9	1	15/16	DTMC-14M-12N
15	1/2	19.0	11.9	38.9	1	15/16	DTMC-15M-8N
16	3/8	14.3	9.5	34.0	1	15/16	DTMC-16M-12N
16	1/2	19.0	11.9	38.9	1	15/16	DTMC-16M-8N
16	3/4	19.0	12.7	40.4	1	1-1/8	DTMC-16M-16N
18	1/2	19.0	11.9	40.4	1-1/8	1-1/16	DTMC-18M-8N
18	3/4	19.0	15.1	40.4	1-1/8	1-1/16	DTMC-18M-12N
20	1/2	19.0	11.9	42.2	1-1/4	1-1/4	DTMC-20M-8N
20	3/4	19.0	15.9	42.2	1-1/4	1-1/4	DTMC-20M-12N
22	3/4	19.0	15.9	42.2	1-1/4	1-1/4	DTMC-22M-12N
22	1	23.9	18.3	47.0	1-1/4	1-3/8	DTMC-22M-16N
25	1/2	19.0	11.9	45.2	1-1/2	1-3/8	DTMC-25M-8N
25	3/4	19.0	15.9	45.2	1-1/2	1-3/8	DTMC-25M-12N
25	1	23.9	21.8	50.0	1-1/2	1-3/8	DTMC-25M-16N

Dimensions are for reference only and are subject to change

Male Connector (*Fractional* Tube to ISO BSP Taper (RT) Male Thread)

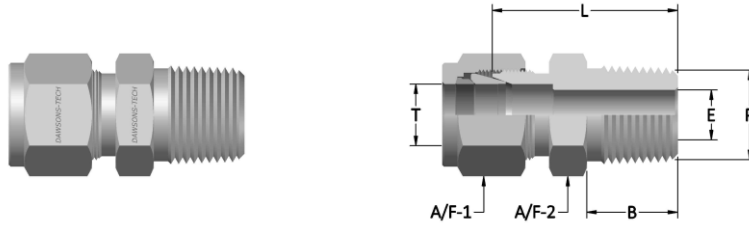

STANDARD CONFIGURATION DIMENSIONS

Tube OD	BSPT Male Thread	Dimension in Inch					Dawsons-Tech Part No.
		T	P	B	E	L	
1/8	1/8	0.38	0.09	0.94	7/16	7/16	DTMC-2-2RT
1/8	1/4	0.56	0.09	1.14	7/16	9/16	DTMC-2-4RT
1/4	1/8	0.38	0.19	1.00	9/16	1/2	DTMC-4-2RT
1/4	1/4	0.56	0.19	1.20	9/16	9/16	DTMC-4-4RT
1/4	3/8	0.56	0.19	1.22	9/16	11/16	DTMC-4-6RT
1/4	1/2	0.75	0.19	1.47	9/16	7/8	DTMC-4-8RT
5/16	1/8	0.38	0.19	1.05	5/8	9/16	DTMC-5-2RT
5/16	1/4	0.56	0.25	1.23	5/8	9/16	DTMC-5-4RT
3/8	1/8	0.38	0.19	1.10	11/16	5/8	DTMC-6-2RT
3/8	1/4	0.56	0.28	1.28	11/16	5/8	DTMC-6-4RT
3/8	3/8	0.56	0.28	1.28	11/16	11/16	DTMC-6-6RT
3/8	1/2	0.75	0.28	1.53	11/16	7/8	DTMC-6-8RT
1/2	1/4	0.56	0.28	1.31	7/8	13/16	DTMC-8-4RT
1/2	3/8	0.56	0.38	1.31	7/8	13/16	DTMC-8-6RT
1/2	1/2	0.75	0.41	1.53	7/8	7/8	DTMC-8-8RT
1/2	3/4	0.75	0.41	1.59	7/8	1-1/8	DTMC-8-12RT
3/4	3/4	0.75	0.62	1.59	1-1/8	1-1/8	DTMC-12-12RT
1	1	0.94	0.88	1.97	1-1/2	1-3/8	DTMC-16-16RT

Dimensions are for reference only and are subject to change

Male Connector (*Metric* Tube to ISO BSP Taper (RT) Male Thread)

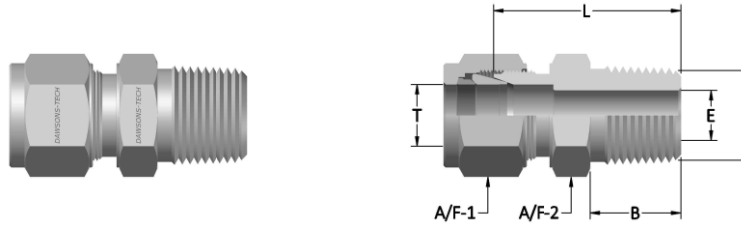

STANDARD CONFIGURATION DIMENSIONS

Tube OD	BSPT Male Thread	Dimension in mm			A/F1	A/F2	Dawsons-Tech Part No.
		T	P	B			
3	1/8	9.7	2.4	23.9	7/16	7/16	DTMC-3M-2RT
3	1/4	14.3	2.4	29.0	7/16	9/16	DTMC-3M-4RT
4	1/8	9.7	2.4	24.6	1/2	7/16	DTMC-4M-2RT
4	1/4	14.3	2.4	29.7	1/2	9/16	DTMC-4M-4RT
6	1/8	9.7	4.8	25.4	9/16	9/16	DTMC-6M-2RT
6	1/4	14.3	4.8	30.5	9/16	9/16	DTMC-6M-4RT
6	3/8	14.3	4.8	31.0	9/16	11/16	DTMC-6M-6RT
6	1/2	19.0	4.8	37.3	9/16	7/8	DTMC-6M-8RT
8	1/8	9.7	4.8	26.7	5/8	9/16	DTMC-8M-2RT
8	1/4	14.3	6.4	31.2	5/8	9/16	DTMC-8M-4RT
8	3/8	14.3	6.4	31.8	5/8	11/16	DTMC-8M-6RT
8	1/2	19.0	6.4	38.1	5/8	7/8	DTMC-8M-8RT
10	1/8	9.7	4.8	28.7	3/4	11/16	DTMC-10M-2RT
10	1/4	14.3	7.9	33.3	3/4	11/16	DTMC-10M-4RT
10	3/8	14.3	7.9	33.3	3/4	11/16	DTMC-10M-6RT
10	1/2	19.0	7.9	38.9	3/4	7/8	DTMC-10M-8RT
12	1/8	9.7	4.8	28.7	7/8	13/16	DTMC-12M-2RT
12	1/4	14.3	7.1	33.3	7/8	13/16	DTMC-12M-4RT
12	3/8	14.3	9.5	33.3	7/8	13/16	DTMC-12M-6RT
12	1/2	19.0	9.5	38.9	7/8	7/8	DTMC-12M-8RT
12	3/4	19.0	9.5	40.4	7/8	1-1/16	DTMC-12M-12RT
15	1/2	19.0	11.9	38.9	1	15/16	DTMC-15M-8RT
16	1/4	14.3	7.1	34.0	1	15/16	DTMC-16M-4RT
16	3/8	14.3	9.5	34.0	1	15/16	DTMC-16M-12RT
16	1/2	19.0	11.9	38.9	1	15/16	DTMC-16M-8RT
16	3/4	19.0	12.7	40.4	1	1-1/16	DTMC-16M-16RT
18	1/2	19.0	11.9	40.4	1-1/8	1-1/16	DTMC-18M-8RT
18	3/4	19.0	15.1	40.4	1-1/8	1-1/16	DTMC-18M-12RT
20	1/2	19.0	11.9	42.2	1-1/4	1-1/4	DTMC-20M-8RT
20	3/4	19.0	15.9	42.2	1-1/4	1-1/4	DTMC-20M-12RT
22	3/4	19.0	15.9	42.2	1-1/4	1-1/4	DTMC-22M-12RT
22	1	23.9	18.3	47.0	1-1/4	1-3/8	DTMC-22M-16RT
25	3/4	19.0	15.9	45.2	1-1/2	1-3/8	DTMC-25M-12RT
25	1	23.9	21.8	50.0	1-1/2	1-3/8	DTMC-25M-16RT

Dimensions are for reference only and are subject to change

Male Connector (*Fractional* Tube to SAE / MS Straight Male Thread Boss Connection)

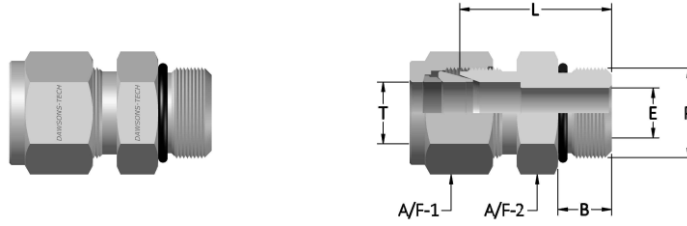

STANDARD CONFIGURATION DIMENSIONS

Tube OD	SAE / MS Straight Thread	Dimension in Inch					Dawsons-Tech Part No.
T	P	B	E	L	A/F1	A/F2	
1/8	5/16 - 24	0.30	0.09	0.92	7/16	7/16	DTMC-2-5SE
1/8	7/16 - 20	0.36	0.09	0.98	7/16	9/16	DTMC-2-7SE
1/8	9/16 - 18	0.39	0.09	1.05	7/16	11/16	DTMC-2-9SE
1/4	7/16 - 20	0.36	0.19	1.05	9/16	9/16	DTMC-4-7SE
1/4	9/16 - 18	0.39	0.19	1.11	9/16	11/16	DTMC-4-9SE
1/4	3/4 - 16	0.44	0.19	1.19	9/16	7/8	DTMC-4-12SE
1/4	7/8 - 14	0.50	0.19	1.31	9/16	1	DTMC-4-14SE
5/16	1/2 - 20	0.36	0.25	1.08	5/8	5/8	DTMC-5-8SE
3/8	7/16 - 20	0.36	0.20	1.11	11/16	5/8	DTMC-6-7SE
3/8	9/16 - 18	0.39	0.28	1.17	11/16	11/16	DTMC-6-9SE
3/8	3/4 - 16	0.44	0.28	1.25	11/16	7/8	DTMC-6-12SE
3/8	7/8 - 14	0.50	0.28	1.37	11/16	1	DTMC-6-14SE
1/2	9/16 - 18	0.39	0.28	1.14	7/8	13/16	DTMC-8-9SE
1/2	3/4 - 16	0.44	0.41	1.25	7/8	7/8	DTMC-8-12SE
1/2	7/8 - 14	0.50	0.41	1.37	7/8	1	DTMC-8-14SE
1/2	1-1/16 - 12	0.59	0.41	1.53	7/8	1-1/4	DTMC-8-17SE
5/8	3/4 - 16	0.44	0.42	1.25	1	15/16	DTMC-10-12SE
5/8	7/8 - 14	0.50	0.50	1.38	1	1	DTMC-10-14SE
3/4	3/4 - 16	0.44	0.42	1.41	1-1/8	1-1/16	DTMC-12-12SE
3/4	1-1/16 - 12	0.59	0.62	1.53	1-1/8	1-1/4	DTMC-12-17SE
7/8	1-3/16 - 12	0.59	0.72	1.53	1-1/4	1-3/8	DTMC-14-19SE
1	1-1/16 - 12	0.59	0.66	1.62	1-1/2	1-3/8	DTMC-16-17SE
1	1-5/16 - 12	0.59	0.88	1.66	1-1/2	1-1/2	DTMC-16-21SE

Dimensions are for reference only and are subject to change

Long Male Connector (*Fractional* Tube to SAE / MS Straight Male Thread Boss Connection)

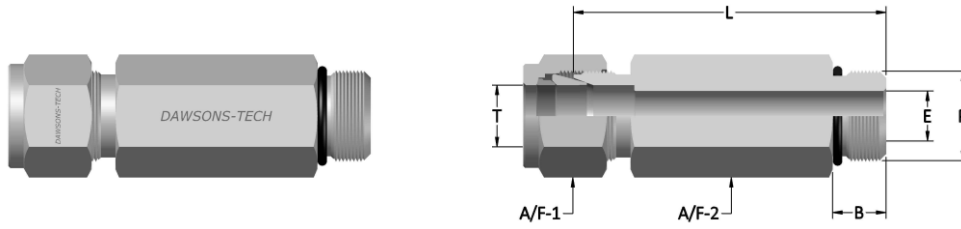

STANDARD CONFIGURATION DIMENSIONS

Tube OD	SAE / MS Straight Thread	Dimension in Inch					Dawsons-Tech Part No.
T	P	B	E	L	A/F1	A/F2	
1/4	7/16 - 20	0.36	0.19	1.97	9/16	9/16	DTLMC-4-7SE
5/16	1/2 - 20	0.36	0.25	2.03	5/8	5/8	DTLMC-5-8SE
3/8	9/16 - 18	0.39	0.28	2.19	11/16	11/16	DTLMC-6-9SE
1/2	3/4 - 16	0.44	0.41	2.58	7/8	7/8	DTLMC-8-12SE
5/8	7/8 - 14	0.50	0.50	2.94	1	1	DTLMC-10-14SE
3/4	1-1/16 - 12	0.59	0.62	3.48	1-1/8	1-1/4	DTLMC-12-17SE
7/8	1-3/16 - 12	0.59	0.72	3.67	1-1/4	1-3/8	DTLMC-14-19SE
1	1-5/16 - 12	0.59	0.88	3.86	1-1/2	1-1/2	DTLMC-16-21SE

Dimensions are for reference only and are subject to change

Male Connector (*Fractional* Tube to EO Seal SAE / MS Straight Male Thread)

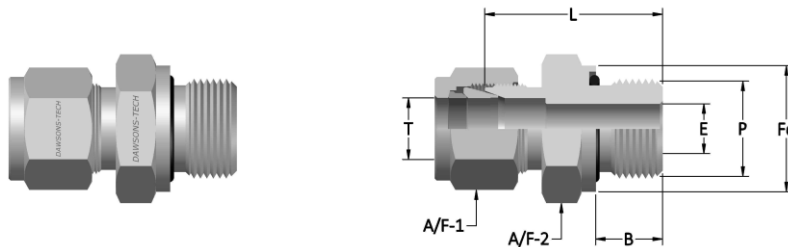

STANDARD CONFIGURATION DIMENSIONS

Tube OD	SAE / MS Straight Thread	Dimension in Inch						Dawsons-Tech Part No.
T	P	B	E	Fd	L	A/F1	A/F2	
1/8	5/16 - 24	0.34	0.09	0.55	1.03	7/16	9/16	DTOMC-2-5SE
3/16	3/8 - 24	0.38	0.12	0.62	1.09	1/2	5/8	DTOMC-3-6SE
1/4	7/16 - 20	0.41	0.19	0.74	1.22	9/16	3/4	DTOMC-4-7SE
5/16	1/2 - 20	0.44	0.25	0.86	1.31	5/8	7/8	DTOMC-5-8SE
3/8	9/16 - 18	0.47	0.28	0.93	1.38	11/16	15/16	DTOMC-6-9SE
1/2	3/4 - 16	0.47	0.41	1.12	1.41	7/8	1-1/8	DTOMC-8-12SE
3/4	1-1/16 - 12	0.56	0.62	1.49	1.66	1-1/8	1-1/2	DTOMC-12-17SE
1	1-5/16 - 12	0.56	0.88	1.74	1.81	1-1/2	1-3/4	DTOMC-16-21SE

Dimensions are for reference only and are subject to change

Male Connector (*Fractional* Tube to EO Seal ISO Parallel Male Thread)

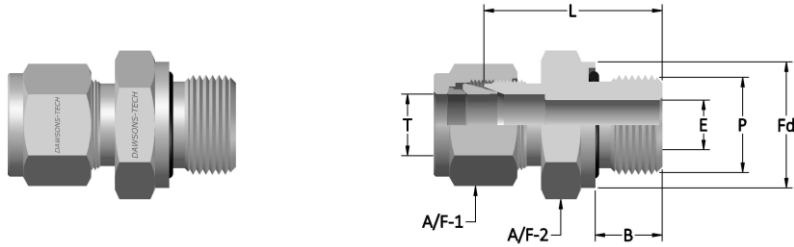

STANDARD CONFIGURATION DIMENSIONS

Tube OD	BSPP Male Thread	Dimension in Inch						Dawsons-Tech Part No.
T	P	B	E	Fd	L	A/F1	A/F2	
1/4	1/4	0.47	0.19	0.74	1.19	9/16	3/4	DTOMC-4-4EO
1/4	1/2	0.55	0.19	1.04	1.38	9/16	1-1/16	DTOMC-4-8EO
3/8	3/8	0.47	0.28	0.86	1.31	11/16	7/8	DTOMC-6-6EO
1/2	1/4	0.47	0.25	0.74	1.31	7/8	13/16	DTOMC-8-4EO
1/2	3/8	0.47	0.31	0.86	1.31	7/8	7/8	DTOMC-8-6EO
1/2	1/2	0.55	0.41	1.04	1.47	7/8	1-1/16	DTOMC-8-8EO
3/4	3/4	0.63	0.63	1.25	1.59	1-1/8	1-5/16	DTOMC-12-12EO

Dimensions are for reference only and are subject to change

Male Connector (*Metric* Tube to EO Seal ISO Parallel Male Thread)

Tube OD	BSPP Male Thread	Dimension in mm				A/F1	A/F2	Dawsons-Tech Part No.
T	P	B	E	Fd	L			
6	1/8	7-9	4.0	13.7	25.0	9/16	9/16	DTOMC-6M-2EO
6	1/4	11.9	4.8	18.8	30.7	9/16	3/4	DTOMC-6M-4EO
6	3/8	11.9	4.8	21.8	32.0	9/16	7/8	DTOMC-6M-6EO
6	1/2	14.0	4.8	26.4	37.0	9/16	1-1/16	DTOMC-6M-8EO
10	1/4	11.9	5.9	18.8	32.3	3/4	3/4	DTOMC-10M-4EO
10	3/8	11.9	7.9	21.8	38.1	3/4	7/8	DTOMC-10M-6EO
10	1/2	14.0	7.9	26.4	38.4	3/4	1-1/16	DTOMC-10M-8EO
12	1/4	11.9	5.9	18.8	33.3	7/8	13/16	DTOMC-12M-4EO
12	3/8	11.9	7.9	21.8	33.5	7/8	7/8	DTOMC-12M-6EO
12	1/2	14.0	9.5	26.4	38.4	7/8	1-1/16	DTOMC-12M-8EO

Dimensions are for reference only and are subject to change

Male Connector (*Fractional* Tube to ISO Parallel (RP) Male Thread)

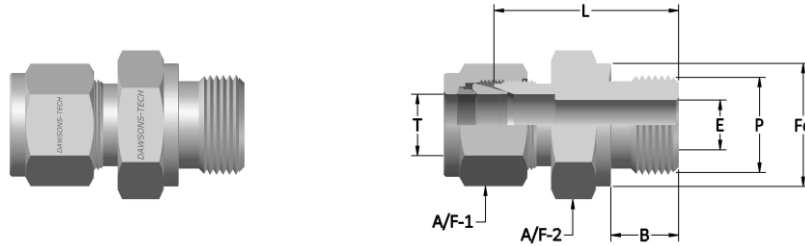

STANDARD CONFIGURATION DIMENSIONS

Tube OD	BSPP Male Thread	Dimension in Inch						Dawsons-Tech Part No.
T	P	B	E	Fd	L	A/F1	A/F2	
1/8	1/8	0.28	0.09	0.54	0.92	7/16	9/16	DTMC-2-2RP
1/8	1/4	0.44	0.09	0.71	1.13	7/16	3/4	DTMC-2-4RP
1/4	1/8	0.28	0.19	0.54	0.98	9/16	9/16	DTMC-4-2RP
1/4	1/4	0.44	0.19	0.71	1.19	9/16	3/4	DTMC-4-4RP
1/2	1/2	0.56	0.41	1.02	1.53	7/8	1-1/16	DTMC-8-8RP

Dimensions are for reference only and are subject to change

Male Connector (*Metric* Tube to ISO Parallel (RP) Male Thread)

Tube OD	BSPP Male Thread	Dimension in mm				A/F1	A/F2	Dawsons-Tech Part No.
T	P	B	E	Fd	L			
3	1/8	7.1	2.4	13.8	23.4	7/16	9/16	DTMC-3M-2RP
3	1/4	11.2	2.4	18.0	28.7	7/16	3/4	DTMC-3M-4RP
4	1/8	7.1	2.4	13.8	24.1	1/2	9/16	DTMC-4M-2RP
6	1/8	7.1	4.0	13.8	24.9	9/16	9/16	DTMC-6M-2RP
6	1/4	11.2	4.8	18.0	30.2	9/16	3/4	DTMC-6M-4RP
6	3/8	11.2	4.8	21.8	31.5	9/16	7/8	DTMC-6M-6RP
6	1/2	14.2	4.8	26.0	37.3	9/16	1-1/16	DTMC-6M-8RP
8	1/8	7.1	4.0	13.8	25.7	5/8	5/8	DTMC-8M-2RP
8	1/4	11.2	6.4	18.0	31.0	5/8	3/4	DTMC-8M-4RP
8	3/8	11.2	6.4	21.8	32.3	5/8	7/8	DTMC-8M-6RP
8	1/2	14.2	6.4	26.0	38.1	5/8	1-1/16	DTMC-8M-8RP
10	1/4	11.2	5.9	18.0	31.8	3/4	3/4	DTMC-10M-4RP
10	3/8	11.2	7.9	21.8	33.0	3/4	7/8	DTMC-10M-6RP
10	1/2	14.2	7.9	26.0	38.9	3/4	1-1/16	DTMC-10M-8RP
12	1/4	11.2	5.9	18.0	32.5	7/8	13/16	DTMC-12M-4RP
12	3/8	11.2	7.9	21.8	33.0	7/8	7/8	DTMC-12M-6RP
12	1/2	14.2	9.5	26.0	38.9	7/8	1-1/16	DTMC-12M-8RP
12	3/4	15.7	9.5	32.0	42.7	7/8	1-1/4	DTMC-12M-12RP
15	1/2	14.2	11.9	26.0	38.9	1	1-1/16	DTMC-15M-8RP
16	3/8	11.2	7.9	21.0	33.8	1	1-5/16	DTMC-16M-12RP
16	1/2	14.2	11.9	26.0	38.9	1	1-1/16	DTMC-16M-8RP
18	1/2	14.2	11.9	26.0	38.9	1-1/8	1-1/16	DTMC-18M-8RP
18	3/4	15.7	15.1	32.0	42.7	1-1/8	1-1/4	DTMC-18M-12RP
20	1/2	14.2	11.9	26.0	40.4	1-1/4	1-1/4	DTMC-20M-8RP
20	3/4	15.7	15.9	32.0	42.7	1-1/4	1-1/4	DTMC-20M-12RP
22	3/4	15.7	15.9	32.0	42.7	1-1/4	1-1/4	DTMC-22M-12RP
22	1	18.3	18.3	39.0	45.2	1-1/4	1-5/8	DTMC-22M-16RP
25	3/4	15.7	15.9	32.0	45.2	1-1/2	1-3/8	DTMC-25M-12RP
25	1	18.3	19.8	39.0	47.8	1-1/2	1-5/8	DTMC-25M-16RP

Dimensions are for reference only and are subject to change

Male Connector (*Fractional* Tube to ISO Parallel (RS) Male Thread)

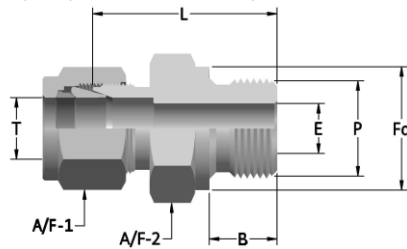
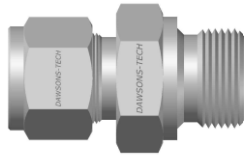

STANDARD CONFIGURATION DIMENSIONS

Tube OD	BSPP Male Thread	Dimension in Inch						Dawsons-Tech Part No.
T	P	B	E	Fd	L	A/F1	A/F2	
1/8	1/8	0.28	0.09	0.54	0.92	7/16	9/16	DTMC-2-2RS
1/8	1/4	0.44	0.09	0.71	1.13	7/16	3/4	DTMC-2-4RS
1/8	3/8	0.44	0.09	0.86	1.17	7/16	7/8	DTMC-2-6RS
1/4	1/8	0.28	0.16	0.54	0.98	9/16	9/16	DTMC-4-2RS
1/4	1/4	0.44	0.19	0.71	1.19	9/16	3/4	DTMC-4-4RS
1/4	3/8	0.44	0.19	0.86	1.24	9/16	7/8	DTMC-4-6RS
1/4	1/2	0.56	0.19	1.02	1.47	9/16	1-1/16	DTMC-4-8RS
3/8	1/4	0.44	0.23	0.71	1.25	11/16	3/4	DTMC-6-4RS
3/8	3/8	0.44	0.28	0.86	1.30	11/16	7/8	DTMC-6-6RS
3/8	1/2	0.56	0.28	1.02	1.53	11/16	1-1/16	DTMC-6-8RS
1/2	1/4	0.44	0.23	0.71	1.28	7/8	13/16	DTMC-8-4RS
1/2	3/8	0.44	0.31	0.86	1.30	7/8	7/8	DTMC-8-6RS
1/2	1/2	0.56	0.41	1.02	1.53	7/8	1-1/16	DTMC-8-8RS
3/4	1/2	0.56	0.47	1.02	1.53	1-1/8	1-1/16	DTMC-12-8RS
3/4	3/4	0.62	0.62	1.26	1.68	1-1/8	1-5/16	DTMC-12-12RS
1	1/2	0.56	0.47	1.02	1.72	1-1/2	1-3/8	DTMC-16-8RS
1	1	0.72	0.78	1.54	1.88	1-1/2	1-5/8	DTMC-16-16RS

Dimensions are for reference only and are subject to change

Male Connector (*Metric* Tube to ISO Parallel (RS) Male Thread)

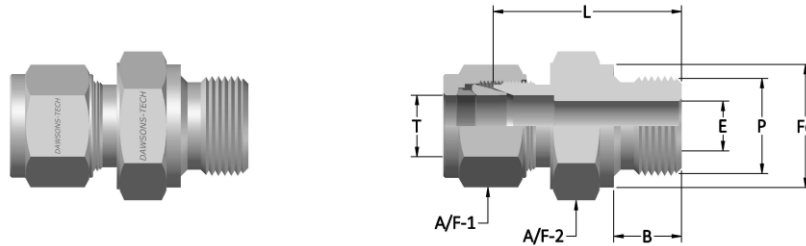

STANDARD CONFIGURATION DIMENSIONS

Tube OD	BSPP Male Thread	Dimension in mm				A/F1	A/F2	Dawsons-Tech Part No.
		T	P	B	E			
3	1/8	7.1	2.4	13.8	23.4	7/16	9/16	DTMC-3M-2RS
3	1/4	11.2	2.4	17.8	28.7	7/16	3/4	DTMC-3M-4RS
4	1/8	7.1	2.4	13.8	24.1	1/2	9/16	DTMC-4M-2RS
6	1/8	7.1	4.0	13.8	24.9	9/16	9/16	DTMC-6M-2RS
6	1/4	11.2	4.8	17.8	30.2	9/16	3/4	DTMC-6M-4RS
6	3/8	11.2	4.8	21.8	31.5	9/16	7/8	DTMC-6M-6RS
6	1/2	14.2	4.8	25.8	37.3	9/16	1-1/16	DTMC-6M-8RS
8	1/8	7.1	4.0	13.8	25.7	5/8	5/8	DTMC-8M-2RS
8	1/4	11.2	6.4	17.8	31.0	5/8	3/4	DTMC-8M-4RS
8	3/8	11.2	6.4	21.8	32.3	5/8	7/8	DTMC-8M-6RS
8	1/2	14.2	6.4	25.8	38.1	5/8	1-1/16	DTMC-8M-8RS
10	1/4	11.2	5.9	17.8	31.8	3/4	3/4	DTMC-10M-4R
10	3/8	11.2	7.9	21.8	33.0	3/4	7/8	DTMC-10M-6RS
10	1/2	14.2	7.9	25.8	38.9	3/4	1-1/16	DTMC-10M-8RS
12	1/4	11.2	5.9	17.8	32.5	7/8	7/8	DTMC-12M-4RS
12	3/8	11.2	7.9	21.8	33.0	7/8	7/8	DTMC-12M-6RS
12	1/2	14.2	9.5	25.8	38.9	7/8	1-1/16	DTMC-12M-8RS
12	3/4	15.7	9.5	31.8	42.7	7/8	1-1/4	DTMC-12M-12RS
16	3/8	11.2	7.9	21.8	33.8	1	15/16	DTMC-16M-12RS
16	1/2	14.2	11.9	25.8	38.9	1	1-1/16	DTMC-16M-8RS
18	1/2	14.2	11.9	25.8	38.9	1-1/8	1-1/16	DTMC-18M-8RS
18	3/4	15.7	15.1	31.8	42.7	1-1/8	1-1/4	DTMC-18M-12RS
20	1/2	14.2	11.9	25.8	40.4	1-1/4	1-1/4	DTMC-20M-8RS
20	3/4	15.7	15.9	31.8	42.7	1-1/4	1-1/4	DTMC-20M-12RS
22	3/4	15.7	15.9	31.8	42.7	1-1/4	1-1/4	DTMC-22M-12RS
22	1	18.3	18.3	38.8	45.2	1-1/4	1-5/8	DTMC-22M-16RS
25	3/4	15.7	15.9	31.8	45.2	1-1/2	1-3/8	DTMC-25M-12RS
25	1	18.3	19.8	38.8	47.8	1-1/2	1-5/8	DTMC-25M-16RS

Dimensions are for reference only and are subject to change

Thermocouple Male Connector (*Fractional* Tube to NPT Male Thread)

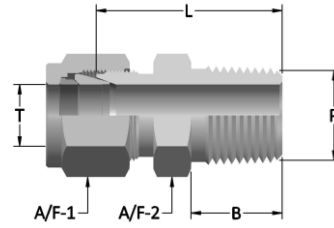
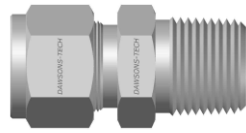

STANDARD CONFIGURATION DIMENSIONS

Tube OD	NPT Male Thread	Dimension in Inch				Dawsons-Tech Part No.
		T	P	B	L	
1/8	1/8	0.38	0.94	7/16	7/16	DTTMC-2-2N
1/8	1/4	0.56	1.14	7/16	9/16	DTTMC-2-4N
3/16	1/8	0.38	0.97	1/2	7/16	DTTMC-3-2N
3/16	1/4	0.56	1.17	1/2	9/16	DTTMC-3-4N
1/4	1/8	0.38	1.00	9/16	1/2	DTTMC-4-2N
1/4	1/4	0.56	1.20	9/16	9/16	DTTMC-4-4N
1/4	3/8	0.56	1.22	9/16	11/16	DTTMC-4-6N
1/4	1/2	0.75	1.47	9/16	7/8	DTTMC-4-8N
5/16	1/4	0.56	1.23	5/8	9/16	DTTMC-5-4N
3/8	1/4	0.56	1.28	11/16	5/8	DTTMC-6-4N
3/8	3/8	0.56	1.28	11/16	11/16	DTTMC-6-6N
3/8	1/2	0.75	1.53	11/16	7/8	DTTMC-6-8N
3/8	3/4	0.75	1.59	11/16	1-1/16	DTTMC-6-12N
1/2	1/2	0.75	1.53	7/8	7/8	DTTMC-8-8N
1/2	3/4	0.75	1.59	7/8	1-1/8	DTTMC-8-12N
5/8	3/4	0.75	1.59	1	1-1/8	DTTMC-10-12N
3/4	3/4	0.75	1.59	1-1/8	1-1/8	DTTMC-12-12N
1	1	0.94	1.97	1-1/2	1-3/8	DTTMC-16-16N

Dimensions are for reference only and are subject to change

Bulkhead Male Connector (*Fractional* Tube to NPT Male Thread)

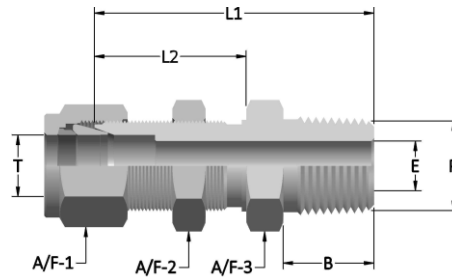
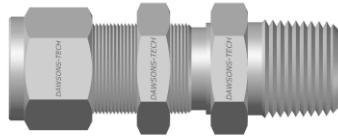

STANDARD CONFIGURATION DIMENSIONS

Tube OD T	NPT Male Thread P	Dimension in Inch							Panel Hole Size	Max. Panel Thickness	Dawsons-Tech Part No.
		B	E	L1	L2	A/F1	A/F2	A/F3			
1/8	1/8	0.38	0.09	1.57	0.97	7/16	1/2	1/2	21/64	0.5	DTBMC-2-2N
3/16	1/8	0.38	0.12	1.63	1.00	7/16	9/16	9/16	25/64	0.5	DTBMC-3-2N
1/4	1/8	0.38	0.19	1.66	1.03	9/16	5/8	5/8	29/64	0.4	DTBMC-4-2N
1/4	1/4	0.56	0.19	1.84	1.03	9/16	5/8	5/8	29/64	0.4	DTBMC-4-4N
1/4	3/8	0.56	0.19	1.87	1.02	9/16	5/8	11/16	29/64	0.4	DTBMC-4-6N
1/4	1/2	0.75	0.19	2.08	1.02	9/16	5/8	7/8	29/64	0.4	DTBMC-4-8N
5/16	1/8	0.38	0.19	1.78	1.12	5/8	11/16	11/16	33/64	0.44	DTBMC-5-2N
5/16	1/4	0.56	0.25	1.97	1.12	5/8	11/16	11/16	33/64	0.44	DTBMC-5-4N
3/8	1/8	0.38	0.19	1.79	1.15	11/16	3/4	3/4	37/64	0.44	DTBMC-6-2N
3/8	1/4	0.56	0.28	1.97	1.16	11/16	3/4	3/4	37/64	0.44	DTBMC-6-4N
3/8	3/8	0.56	0.28	1.97	1.16	11/16	3/4	3/4	37/64	0.44	DTBMC-6-6N
3/8	1/2	0.75	0.28	2.22	1.16	11/16	3/4	7/8	37/64	0.44	DTBMC-6-8N
1/2	1/4	0.56	0.28	2.09	1.25	7/8	15/16	15/16	49/64	0.5	DTBMC-8-4N
1/2	3/8	0.56	0.38	2.09	1.25	7/8	15/16	15/16	49/64	0.5	DTBMC-8-6N
1/2	1/2	0.75	0.41	2.31	1.25	7/8	15/16	15/16	49/64	0.5	DTBMC-8-8N
1/2	3/4	0.75	0.41	2.32	1.25	7/8	15/16	1-1/8	49/64	0.5	DTBMC-8-12N
5/8	3/8	0.56	0.38	2.23	1.28	1	1-1/16	1-1/16	57/64	0.5	DTBMC-10-6N
5/8	1/2	0.75	0.47	2.41	1.28	1	1-1/16	1-1/16	57/64	0.5	DTBMC-10-8N
3/4	1/2	0.75	0.47	2.60	1.47	1-1/8	1-3/16	1-3/16	1-1/64	0.66	DTBMC-12-8N
3/4	3/4	0.75	0.62	2.60	1.47	1-1/8	1-3/16	1-3/16	1-1/64	0.66	DTBMC-12-12N
7/8	3/4	0.75	0.62	2.91	1.69	1-1/4	1-3/8	1-3/8	1-9/64	0.66	DTBMC-14-12N
1	3/4	0.75	0.62	3.00	1.78	1-1/2	1-5/8	1-5/8	1-21/64	0.75	DTBMC-16-12N
1	1	0.94	0.88	3.19	1.78	1-1/2	1-5/8	1-5/8	1-21/64	0.75	DTBMC-16-16N

Dimensions are for reference only and are subject to change

Bulkhead Male Connector (*Metric* Tube to NPT Male Thread)

Tube OD T	NPT Male Thread P	Dimension in mm				A/F1	A/F2	A/F3	Panel Hole Size	Max. Panel Thickness	Dawsons-Tech Part No.
		B	E	L1	L2						
6	1/8	9.7	4.8	42.1	26.2	9/16	5/8	5/8	11.5	10.2	DTBMC-6M-2N
6	1/4	14.2	4.8	46.0	26.2	9/16	5/8	5/8	11.5	10.2	DTBMC-6M-4N
8	1/8	9.7	4.8	44.8	28.5	5/8	11/16	11/16	13.1	11.2	DTBMC-8M-2N
8	1/4	14.2	6.4	50.0	28.5	5/8	11/16	11/16	13.1	11.2	DTBMC-8M-4N
10	1/4	14.2	7.1	50.8	29.4	3/4	7/8	7/8	16.3	11.2	DTBMC-10M-4N
10	3/8	14.2	7.9	50.8	29.4	3/4	7/8	7/8	16.3	11.2	DTBMC-10M-6N
10	1/2	19.0	7.9	55.5	29.4	3/4	7/8	7/8	16.3	11.2	DTBMC-10M-8N
12	1/4	14.2	7.1	53.2	31.8	7/8	15/16	15/16	19.5	12.7	DTBMC-12M-4N
12	3/8	14.2	9.5	54.4	31.8	7/8	15/16	15/16	19.5	12.7	DTBMC-12M-6N
12	1/2	19.0	9.5	57.4	31.8	7/8	15/16	15/16	19.5	12.7	DTBMC-12M-8N

Dimensions are for reference only and are subject to change

Male Elbow (*Fractional* Tube to NPT Male Thread)

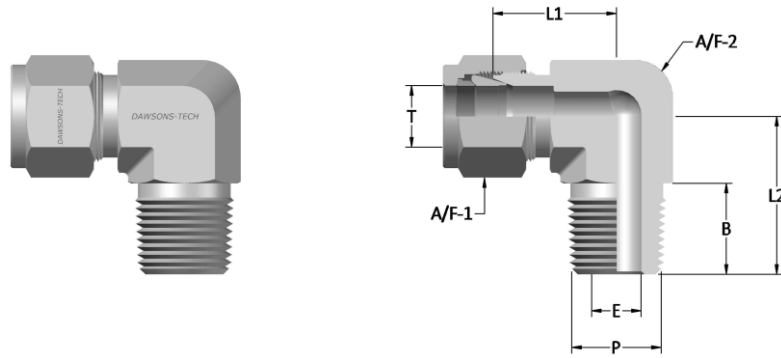

STANDARD CONFIGURATION DIMENSIONS

Tube OD	NPT Male Thread	Dimension in Inch						Dawsons-Tech Part No.
T	P	B	E	L1	L2	A/F1	A/F2	
1/8	1/8	0.38	0.09	0.94	0.70	7/16	7/16	DTME-2-2N
1/8	1/4	0.56	0.09	1.14	0.92	7/16	9/16	DTME-2-4N
3/16	1/8	0.38	0.12	0.97	0.74	1/2	1/2	DTME-3-2N
3/16	1/4	0.56	0.12	1.17	0.92	1/2	9/16	DTME-3-4N
1/4	1/8	0.38	0.19	1.00	0.74	9/16	1/2	DTME-4-2N
1/4	1/4	0.56	0.19	1.20	0.92	9/16	9/16	DTME-4-4N
1/4	3/8	0.56	0.19	1.22	1.03	9/16	11/16	DTME-4-6N
1/4	1/2	0.75	0.19	1.47	1.30	9/16	7/8	DTME-4-8N
5/16	1/8	0.38	0.19	1.05	0.78	5/8	9/16	DTME-5-2N
5/16	1/4	0.56	0.25	1.23	0.96	5/8	9/16	DTME-5-4N
5/16	3/8	0.56	0.25	1.25	1.03	5/8	11/16	DTME-5-6N
3/8	1/8	0.38	0.19	1.10	0.82	11/16	5/8	DTME-6-2N
3/8	1/4	0.56	0.28	1.28	1.00	11/16	5/8	DTME-6-4N
3/8	3/8	0.56	0.28	1.28	1.03	11/16	11/16	DTME-6-6N
3/8	1/2	0.75	0.28	1.53	1.30	11/16	7/8	DTME-6-8N
3/8	3/4	0.75	0.28	1.59	1.45	11/16	1-1/8	DTME-6-12N
1/2	1/4	0.56	0.28	1.31	1.11	7/8	13/16	DTME-8-4N
1/2	3/8	0.56	0.38	1.31	1.11	7/8	13/16	DTME-8-6N
1/2	1/2	0.75	0.41	1.53	1.30	7/8	7/8	DTME-8-8N
1/2	3/4	0.75	0.41	1.59	1.45	7/8	1-1/8	DTME-8-12N
5/8	3/8	0.56	0.38	1.34	1.19	1	15/16	DTME-10-6N
5/8	1/2	0.75	0.47	1.53	1.38	1	15/16	DTME-10-8N
5/8	3/4	0.75	0.50	1.59	1.45	1	1-1/8	DTME-10-12N
3/4	1/2	0.75	0.47	1.59	1.45	1-1/8	1-1/16	DTME-12-8N
3/4	3/4	0.75	0.62	1.59	1.45	1-1/8	1-1/8	DTME-12-12N
7/8	3/4	0.75	0.62	1.59	1.64	1-1/4	1-3/8	DTME-14-12N
1	3/4	0.75	0.62	1.78	1.64	1-1/2	1-3/8	DTME-16-12N
1	1	0.94	0.88	1.97	1.83	1-1/2	1-3/8	DTME-16-16N

Dimensions are for reference only and are subject to change

Male Elbow (*Metric* Tube to NPT Male Thread)

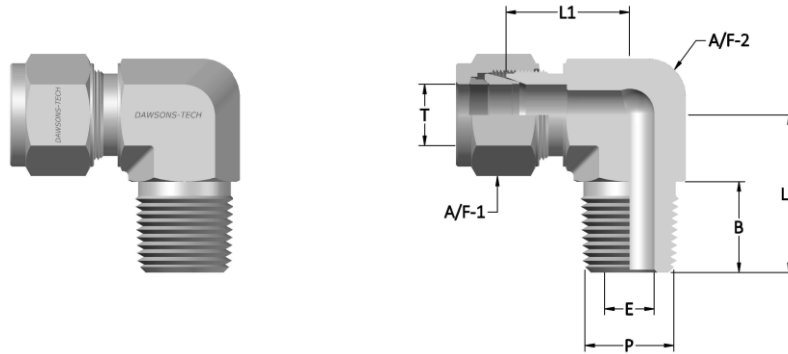

STANDARD CONFIGURATION DIMENSIONS

Tube OD T	NPT Male Thread P	Dimension in mm				A/F1	A/F2	Dawsons-Tech Part No.
		B	E	L1	L2			
3	1/8	9.7	2.4	17.0	17.8	7/16	7/16	DTME-3M-2N
3	1/4	14.3	2.4	18.0	23.4	7/16	9/16	DTME-3M-4N
4	1/8	9.7	2.4	18.8	18.8	1/2	1/2	DTME-4M-2N
4	1/4	14.3	2.4	18.8	23.4	1/2	9/16	DTME-4M-4N
6	1/8	9.7	4.8	19.6	18.8	9/16	1/2	DTME-6M-2N
6	1/4	14.3	4.8	19.6	23.4	9/16	9/16	DTME-6M-4N
6	3/8	14.3	4.8	22.4	26.2	9/16	11/16	DTME-6M-6N
6	1/2	19.0	4.8	24.4	33.0	9/16	7/8	DTME-6M-8N
8	1/8	9.7	4.8	21.3	19.8	5/8	9/16	DTME-8M-2N
8	1/4	14.3	6.4	21.3	24.4	5/8	9/16	DTME-8M-4N
8	3/8	14.3	6.4	23.1	26.2	5/8	11/16	DTME-8M-6N
8	1/2	19.0	6.4	25.1	33.0	5/8	7/8	DTME-8M-8N
10	1/4	14.3	7.9	23.9	26.2	3/4	11/16	DTME-10M-4N
10	3/8	14.3	7.9	23.9	26.2	3/4	11/16	DTME-10M-6N
10	1/2	19.0	7.9	25.9	33.0	3/4	7/8	DTME-10M-8N
12	1/4	14.3	7.1	25.9	28.2	7/8	13/16	DTME-12M-4N
12	3/8	14.3	9.5	25.9	28.2	7/8	13/16	DTME-12M-6N
12	1/2	19.0	9.5	25.9	33.0	7/8	7/8	DTME-12M-8N
12	3/4	19.0	9.5	29.7	36.8	7/8	1-1/8	DTME-12M-12N
15	1/2	19.0	11.9	27.9	35.1	1	15/16	DTME-15M-8N
16	3/8	14.3	9.5	27.9	30.2	1	15/16	DTME-16M-12N
16	1/2	19.0	11.9	27.9	35.1	1	15/16	DTME-16M-8N
16	3/4	19.0	12.7	29.7	36.8	1	1-1/8	DTME-16M-16N
18	1/2	19.0	11.9	29.7	36.8	1-1/8	1-1/16	DTME-18M-8N
18	3/4	19.0	15.1	29.7	36.8	1-1/8	1-1/8	DTME-18M-12N
20	1/2	19.0	11.9	34.5	41.7	1-1/4	1-1/4	DTME-20M-8N
20	3/4	19.0	15.9	34.5	41.7	1-1/4	1-1/4	DTME-20M-12N
22	3/4	19.0	15.9	34.5	41.7	1-1/4	1-1/4	DTME-22M-12N
22	1	23.9	18.3	34.5	46.5	1-1/4	1-3/8	DTME-22M-16N
25	3/4	19.0	15.9	36.8	41.7	1-1/2	1-3/8	DTME-25M-12N
25	1	23.9	21.8	36.8	46.5	1-1/2	1-3/8	DTME-25M-16N

Dimensions are for reference only and are subject to change

Male Elbow (*Fractional* Tube to BSPT Male Thread)

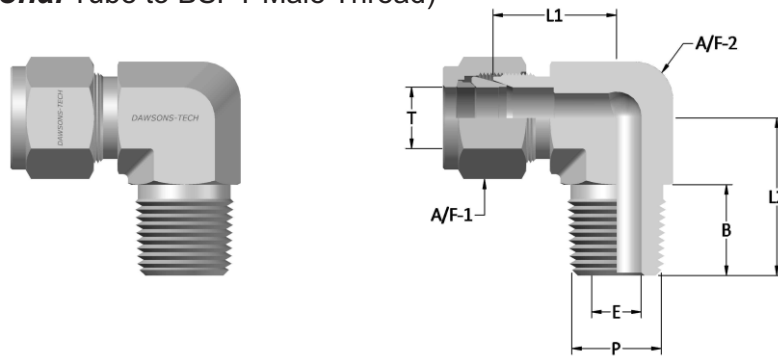

STANDARD CONFIGURATION DIMENSIONS

Tube OD	BSPT Male Thread	Dimension in Inch						Dawsons-Tech Part No.
T	P	B	E	L1	L2	A/F1	A/F2	
1/4	1/8	0.38	0.19	0.77	0.74	9/16	1/2	DTME-4-2RT
1/4	1/4	0.56	0.19	0.77	0.92	9/16	9/16	DTME-4-4RT
1/4	3/8	0.56	0.19	0.88	1.03	9/16	11/16	DTME-4-6RT
1/4	1/2	0.75	0.19	0.96	1.30	9/16	7/8	DTME-4-8RT
5/16	1/4	0.56	0.25	0.84	0.96	5/8	9/16	DTME-5-4RT
3/8	1/4	0.56	0.28	0.91	1.00	11/16	5/8	DTME-6-4RT
3/8	3/8	0.56	0.28	0.94	1.03	11/16	11/16	DTME-6-6RT

Dimensions are for reference only and are subject to change

Male Elbow (*Metric* Tube to BSPT Male Thread)

Tube OD	BSPT Male Thread	Dimension in mm				A/F1	A/F2	Dawsons-Tech Part No.
T	P	B	E	L1	L2			
3	1/8	9.7	2.4	17.0	17.8	7/16	7/16	DTME-3M-2RT
3	1/4	14.3	2.4	18.0	23.4	7/16	9/16	DTME-3M-4RT
4	1/8	9.7	2.4	18.8	18.8	1/2	1/2	DTME-4M-2RT
4	1/4	14.3	2.4	18.8	23.4	1/2	9/16	DTME-4M-4RT
6	1/8	9.7	4.8	19.6	18.8	9/16	1/2	DTME-6M-2RT
6	1/4	14.3	4.8	19.6	23.4	9/16	9/16	DTME-6M-4RT
6	3/8	14.3	4.8	22.4	26.2	9/16	11/16	DTME-6M-6RT
6	1/2	19.0	4.8	24.4	33.0	9/16	7/8	DTME-6M-8RT
8	1/8	9.7	4.8	21.3	19.8	5/8	9/16	DTME-8M-2RT
8	1/4	14.3	6.4	21.3	24.4	5/8	9/16	DTME-8M-4RT
8	3/8	14.3	6.4	23.1	26.2	5/8	11/16	DTME-8M-6RT
8	1/2	19.0	6.4	25.1	33.0	5/8	7/8	DTME-8M-8RT
10	1/4	14.3	7.1	23.9	26.2	3/4	11/16	DTME-10M-4RT
10	3/8	14.3	7.9	23.9	26.2	3/4	11/16	DTME-10M-6RT
10	1/2	19.0	7.9	25.9	33.0	3/4	7/8	DTME-10M-8RT
12	1/4	14.3	7.1	25.9	28.2	7/8	13/16	DTME-12M-4RT
12	3/8	14.3	9.5	25.9	28.2	7/8	13/16	DTME-12M-6RT
12	1/2	19.0	9.5	25.9	33.0	7/8	7/8	DTME-12M-8RT
12	3/4	19.0	9.5	29.7	36.8	7/8	1-1/8	DTME-12M-12RT
16	3/8	14.3	9.5	27.9	30.2	1	15/16	DTME-16M-12RT
16	1/2	19.0	11.9	27.9	35.1	1	15/16	DTME-16M-8RT
18	1/2	19.0	11.9	29.7	36.8	1-1/8	1-1/16	DTME-18M-8RT
18	3/4	19.0	15.1	29.7	36.8	1-1/8	1-1/8	DTME-18M-12RT
20	1/2	19.0	11.9	34.5	41.7	1-1/4	1-1/4	DTME-20M-8RT
20	3/4	19.0	15.9	34.5	41.7	1-1/4	1-1/4	DTME-20M-12RT
22	3/4	19.0	15.9	34.5	41.7	1-1/4	1-1/4	DTME-22M-12RT
22	1	23.9	18.3	34.5	46.5	1-1/4	1-3/8	DTME-22M-16RT
25	3/4	19.0	15.9	36.8	41.7	1-1/2	1-3/8	DTME-25M-12RT
25	1	23.9	21.8	36.8	46.5	1-1/2	1-3/8	DTME-25M-16RT

Dimensions are for reference only and are subject to change

Positionable Male Elbow (*Fractional* Tube to SAE / MS Straight Male Thread Boss Connection)

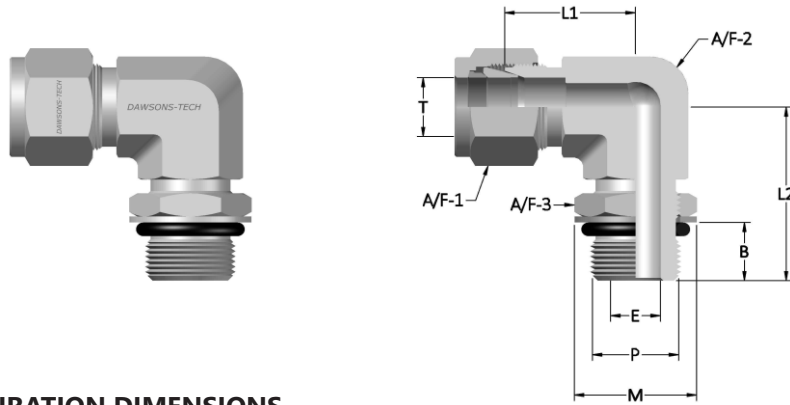

STANDARD CONFIGURATION DIMENSIONS

Tube OD	SAE / MS Straight Thread	Dimension in Inch								Dawsons-Tech Part No.
		T	P	B	E	L1	L2	M	A/F1	
1/4	7/16 - 20	0.39	0.19	0.83	1.12	0.65	9/16	1/2	9/16	DTPME-4-7SE
1/4	9/16 - 18	0.44	0.19	0.91	1.27	0.79	9/16	5/8	11/16	DTPME-4-9SE
5/16	1/2 - 20	0.39	0.23	0.90	1.16	0.72	5/8	9/16	5/8	DTPME-5-8SE
3/8	9/16 - 18	0.44	0.28	0.97	1.27	0.79	11/16	5/8	11/16	DTPME-6-9SE
3/8	3/4 - 16	0.50	0.28	1.08	1.49	1.01	11/16	13/16	7/8	DTPME-6-12SE
1/2	3/4 - 16	0.50	0.41	1.08	1.49	1.01	7/8	13/16	7/8	DTPME-8-12SE
5/8	7/8 - 14	0.56	0.50	1.16	1.71	1.16	1	15/16	1	DTPME-10-14SE
3/4	1-1/16 - 12	0.66	0.62	1.23	1.92	1.44	1-1/8	1-1/16	1-1/4	DTPME-12-17SE
7/8	1-3/16 - 12	0.66	0.72	1.30	1.99	1.59	1-1/4	1-3/8	1-3/8	DTPME-14-19SE
1	1-5/16 - 12	0.66	0.88	1.51	2.11	1.73	1-1/2	1-1/2	1-1/2	DTPME-16-21SE

Dimensions are for reference only and are subject to change

Positionable Male Elbow (*Fractional* Tube to ISO Parallel (PR) Male Thread)

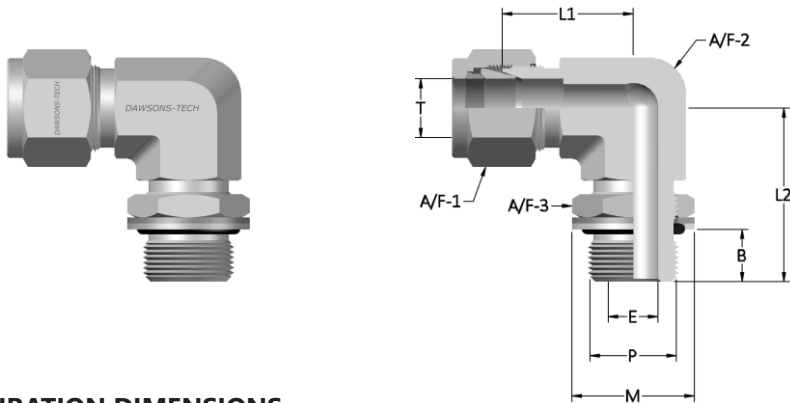

STANDARD CONFIGURATION DIMENSIONS

Tube OD	BSPP Male Thread	Dimension in Inch								Dawsons-Tech Part No.
		T	P	B	E	L1	L2	M	A/F1	
1/4	1/8	0.32	0.16	0.77	1.04	0.68	9/16	1/2	9/16	DTPME-4-2PR
1/4	1/4	0.36	0.19	0.85	1.27	0.90	9/16	5/8	3/4	DTPME-4-4PR
3/8	1/4	0.36	0.23	0.91	1.27	0.90	11/16	5/8	3/4	DTPME-6-4PR
3/8	3/8	0.37	0.28	1.02	1.46	1.04	11/16	13/16	7/8	DTPME-6-6PR
1/2	1/4	0.36	0.23	1.02	1.38	0.90	7/8	13/16	3/4	DTPME-8-4PR
1/2	3/8	0.37	0.31	1.02	1.46	1.04	7/8	13/16	7/8	DTPME-8-6PR
1/2	1/2	0.51	0.41	1.10	1.71	1.26	7/8	15/16	1-1/16	DTPME-8-8PR
5/8	1/2	0.51	0.47	1.10	1.71	1.26	1	15/16	1-1/16	DTPME-10-8PR
3/4	1/2	0.51	0.47	1.17	1.78	1.26	1-1/8	1-1/16	1-1/16	DTPME-12-8PR
3/4	3/4	0.51	0.62	1.17	1.92	1.62	1-1/8	1-1/16	1-3/8	DTPME-12-12PR
1	3/4	0.51	0.62	1.45	2.10	1.62	1-1/2	1-3/8	1-3/8	DTPME-16-8PR
1	1	0.55	0.78	1.45	2.11	1.91	1-1/2	1-3/8	1-5/8	DTPME-16-16PR

Dimensions are for reference only and are subject to change

Positionable Male Elbow (*Metric* Tube to ISO Parallel (PR) Male Thread)

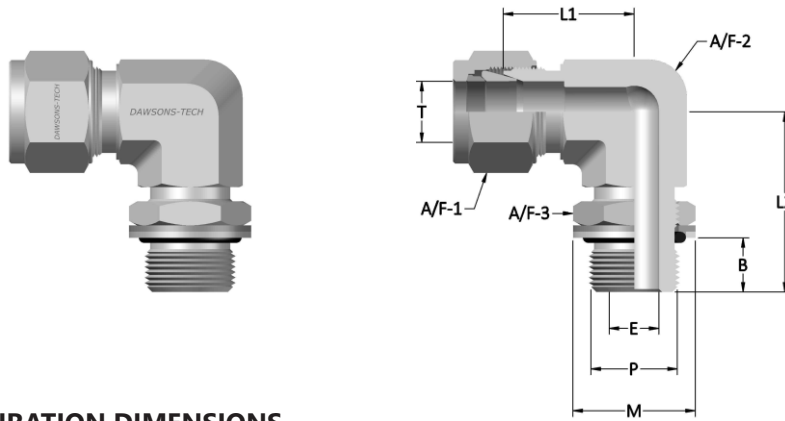

STANDARD CONFIGURATION DIMENSIONS

Tube OD	BSPP Male Thread	Dimension in mm					A/F1	A/F2	A/F3	Dawsons-Tech Part No.
		T	P	B	E	L1				
6	1/8	8.1	4.0	19.6	26.4	17.3	9/16	1/2	9/16	DTPME-6M-2PR
6	1/4	9.1	4.8	21.6	32.3	22.9	9/16	5/8	3/4	DTPME-6M-4PR
8	1/8	8.1	4.0	21.3	27.4	17.3	5/8	9/16	9/16	DTPME-8M-2PR
8	1/4	9.1	5.9	22.4	32.2	22.9	5/8	5/8	3/4	DTPME-8M-4PR
10	1/4	9.1	5.9	25.9	35.0	22.9	3/4	13/16	3/4	DTPME-10M-4PR
10	3/8	9.4	7.9	25.9	37.1	26.4	3/4	13/16	7/8	DTPME-10M-6PR
12	1/4	9.1	5.9	25.9	35.0	22.9	7/8	13/16	3/4	DTPME-12M-4PR
12	3/8	9.4	7.9	25.9	37.1	26.4	7/8	13/16	7/8	DTPME-12M-6PR
12	1/2	13.0	9.5	27.9	43.4	32.0	7/8	15/16	1-1/16	DTPME-12M-8PR
12	3/4	13.0	9.5	29.7	48.8	41.1	7/8	1-1/16	1-3/8	DTPME-12M-12PR

Dimensions are for reference only and are subject to change

Male Branch Tee (*Fractional* Tube to NPT Male Thread)

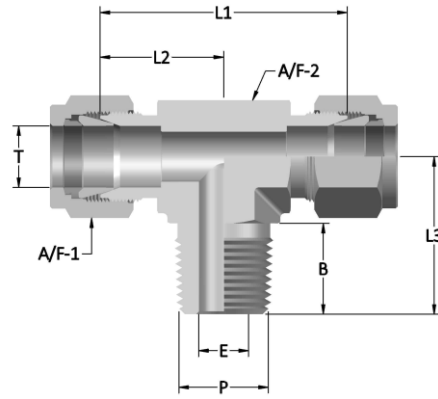
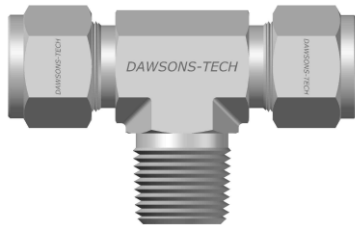

STANDARD CONFIGURATION DIMENSIONS

Tube OD	NPT Male Thread	Dimension in Inch							Dawsons-Tech Part No.
T	P	B	E	L1	L2	L3	A/F1	A/F2	
1/8	1/8	0.38	0.09	1.34	0.67	0.70	7/16	7/16	DTMBT-2-2N
1/8	1/4	0.56	0.09	1.42	0.71	0.92	7/16	9/16	DTMBT-2-4N
3/16	1/8	0.38	0.12	1.40	0.70	0.70	1/2	7/16	DTMBT-3-2N
1/4	1/8	0.38	0.19	1.54	0.77	0.74	9/16	1/2	DTMBT-4-2N
1/4	1/4	0.56	0.19	1.54	0.77	0.92	9/16	9/16	DTMBT-4-4N
5/16	1/8	0.38	0.19	1.76	0.88	0.82	5/8	9/16	DTMBT-5-2N
3/8	1/4	0.56	0.28	1.82	0.91	1.00	11/16	5/8	DTMBT-6-4N
3/8	3/8	0.56	0.28	2.04	1.02	1.11	11/16	13/16	DTMBT-6-6N
1/2	3/8	0.56	0.38	2.04	1.02	1.11	7/8	13/16	DTMBT-8-6N
1/2	1/2	0.75	0.41	2.04	1.02	1.30	7/8	7/8	DTMBT-8-8N
5/8	1/2	0.75	0.47	2.26	1.13	1.41	1	1	DTMBT-10-8N
3/4	3/4	0.75	0.62	2.34	1.17	1.45	1-1/8	1-1/8	DTMBT-12-12N

Dimensions are for reference only and are subject to change

Male Branch Tee (*Metric* Tube to NPT Male Thread)

Tube OD	NPT Male Thread	Dimension in mm					A/F1	A/F2	Dawsons-Tech Part No.
T	P	B	E	L1	L2	L3			
6	1/8	9.7	4.8	39.1	19.6	18.8	9/16	7/16	DTMBT-6M-2N
6	1/4	14.2	4.8	39.1	19.6	23.4	9/16	9/16	DTMBT-6M-4N
8	1/8	9.7	4.8	44.7	22.4	20.8	5/8	1/2	DTMBT-8M-2N
8	1/4	14.2	6.4	44.7	22.4	25.4	5/8	9/16	DTMBT-8M-4N
10	1/4	14.2	7.1	51.8	25.9	28.2	3/4	9/16	DTMBT-10M-4N
12	1/4	14.2	7.1	51.8	25.9	28.2	7/8	5/8	DTMBT-12M-4N
12	3/8	14.2	9.5	51.8	25.9	28.2	7/8	13/16	DTMBT-12M-6N
12	1/2	19.0	9.5	51.8	25.9	33.0	7/8	13/16	DTMBT-12M-8N
16	1/2	19.0	11.9	57.4	28.7	35.8	1	1	DTMBT-16M-8N

Dimensions are for reference only and are subject to change

Male Run Tee (*Fractional* Tube to NPT Male Thread)

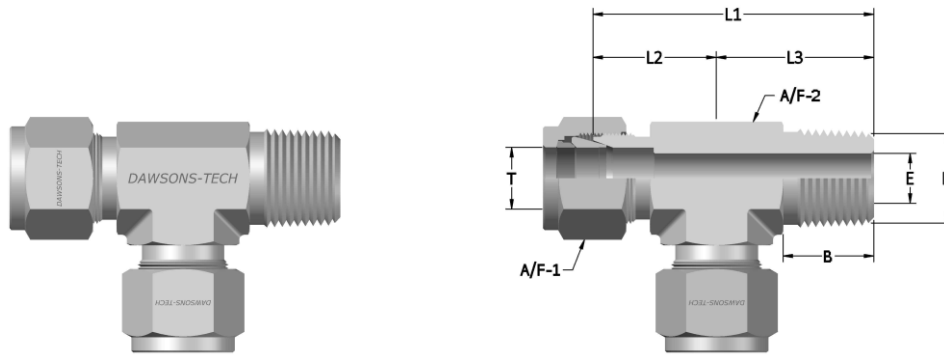

STANDARD CONFIGURATION DIMENSIONS

Tube OD	NPT Male Thread	Dimension in Inch							Dawsons-Tech Part No.
T	P	B	E	L1	L2	L3	A/F1	A/F2	
1/8	1/8	0.38	0.09	1.37	0.67	0.70	7/16	7/16	DTMRT-2-2N
1/8	1/4	0.56	0.09	1.63	0.71	0.92	7/16	9/16	DTMRT-2-4N
3/16	1/8	0.38	0.12	1.40	0.70	0.70	1/2	7/16	DTMRT-3-2N
1/4	1/8	0.38	0.19	1.51	0.77	0.74	9/16	1/2	DTMRT-4-2N
1/4	1/4	0.56	0.19	1.69	0.77	0.92	9/16	9/16	DTMRT-4-4N
5/16	1/8	0.38	0.19	1.70	0.88	0.82	5/8	9/16	DTMRT-5-2N
3/8	1/4	0.56	0.28	1.91	0.91	1.00	11/16	5/8	DTMRT-6-4N
3/8	3/8	0.56	0.28	2.13	1.02	1.11	11/16	13/16	DTMRT-6-6N
1/2	3/8	0.56	0.38	2.13	1.02	1.11	7/8	13/16	DTMRT-8-6N
1/2	1/2	0.75	0.41	2.32	1.02	1.30	7/8	7/8	DTMRT-8-8N
5/8	1/2	0.75	0.47	2.48	1.13	1.41	1	1	DTMRT-10-8N
3/4	3/4	0.75	0.62	2.62	1.17	1.45	1-1/8	1-1/8	DTMRT-12-12N

Dimensions are for reference only and are subject to change

Male Run Tee (*Metric* Tube to NPT Male Thread)

Tube OD	NPT Male Thread	Dimension in mm					A/F1	A/F2	Dawsons-Tech Part No.
T	P	B	E	L1	L2	L3			
6	1/8	9.7	4.8	38.4	19.6	18.0	9/16	1/2	DTMRT-6M-2N
6	1/4	14.2	4.8	42.9	19.6	23.4	9/16	9/16	DTMRT-6M-4N
8	1/4	14.2	6.4	47.8	22.4	25.4	5/8	9/16	DTMRT-8M-4N
12	1/4	14.2	7.1	54.1	25.9	28.2	1/2	13/16	DTMRT-12M-4N
12	3/8	14.2	9.5	54.1	25.9	28.2	7/8	13/16	DTMRT-12M-6N
12	1/2	19.0	9.5	58.9	25.9	33.0	7/8	7/8	DTMRT-12M-6N
16	1/2	19.0	11.9	63.0	27.9	35.0	1	15/16	DTMRT-16M-8N

Dimensions are for reference only and are subject to change

Positionable Male Branch Tee (*Fractional* Tube to SAE / MS Straight Male Thread Boss Connection)

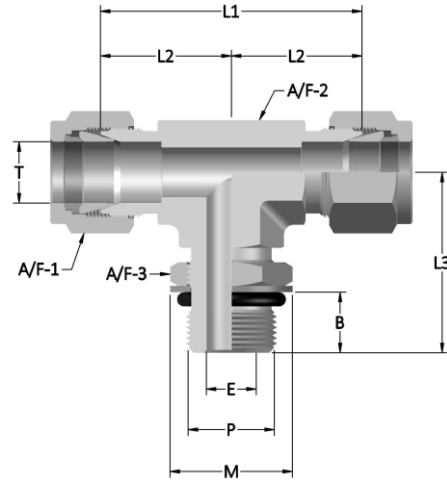
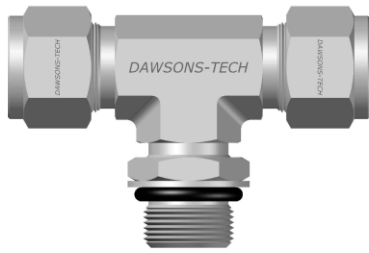

STANDARD CONFIGURATION DIMENSIONS

Tube OD	SAE / MS Straight Thread	Dimension in Inch									Dawsons-Tech Part No.
T	P	B	E	L1	L2	L3	M	A/F1	A/F2	A/F3	
1/4	7/16 - 20	0.39	0.19	1.66	0.83	1.12	0.65	9/16	1/2	9/16	DTPMBT-4-7SE
3/8	9/16 - 18	0.44	0.28	1.94	0.97	1.27	0.79	11/16	5/8	11/16	DTPMBT-6-9SE
1/2	3/4 - 16	0.50	0.41	2.16	1.08	1.49	1.01	7/8	13/16	7/8	DTPMBT-8-12SE
3/4	1-1/16 - 12	0.66	0.62	2.46	1.23	1.92	1.44	1-1/8	1-1/16	1-1/4	DTPMBT-12-17SE
1	1-5/16 - 12	0.66	0.88	3.02	1.51	2.11	1.73	1-1/2	1-3/8	1-1/2	DTPMBT-16-21SE

Dimensions are for reference only and are subject to change

Positionable Male Branch Tee (*Fractional* Tube to ISO Parallel (PR) Male Thread)

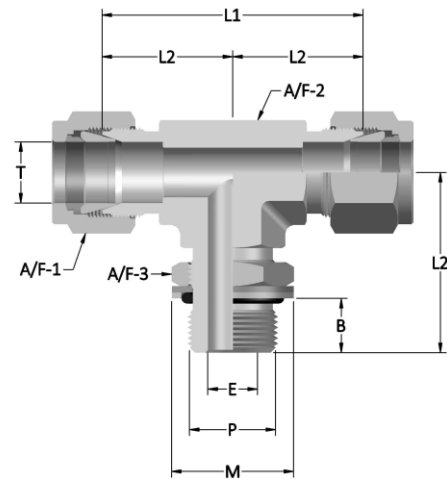
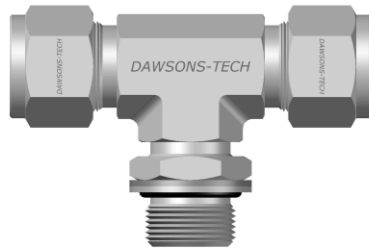

STANDARD CONFIGURATION DIMENSIONS

Tube OD	BSPP Male Thread	Dimension in Inch									Dawsons-Tech Part No.
T	P	B	E	L1	L2	L3	M	A/F1	A/F2	A/F3	
1/4	1/8	0.32	0.16	1.54	0.77	1.04	0.68	9/16	1/2	9/16	DTPMBT-4-2PR
1/4	1/4	0.36	0.19	1.70	0.85	1.27	0.90	9/16	5/8	3/4	DTPMBT-4-4PR
3/8	1/4	0.36	0.23	1.82	0.91	1.27	0.90	11/16	5/8	3/4	DTPMBT-6-4PR
1/2	3/8	0.37	0.31	2.04	1.02	1.46	1.04	7/8	13/16	7/8	DTPMBT-8-6PR
1/2	1/2	0.51	0.41	2.20	1.10	1.71	1.26	7/8	15/16	1-1/16	DTPMBT-8-8PR
5/8	1/2	0.51	0.47	2.20	1.10	1.71	1.26	1	15/16	1-1/16	DTPMBT-10-8PR
3/4	1/2	0.51	0.47	2.34	1.17	1.78	1.26	1-1/8	1-1/16	1-1/16	DTPMBT-12-8PR
3/4	3/4	0.51	0.62	2.34	1.17	1.92	1.62	1-1/8	1-1/16	1-3/8	DTPMBT-12-12PR
1	1	0.55	0.78	2.90	1.45	2.11	1.91	1-1/2	1-3/8	1-5/8	DTPMBT-16-16PR

Dimensions are for reference only and are subject to change

Positionable Male Branch Tee (*Metric* Tube to ISO Parallel (PR) Male Thread)

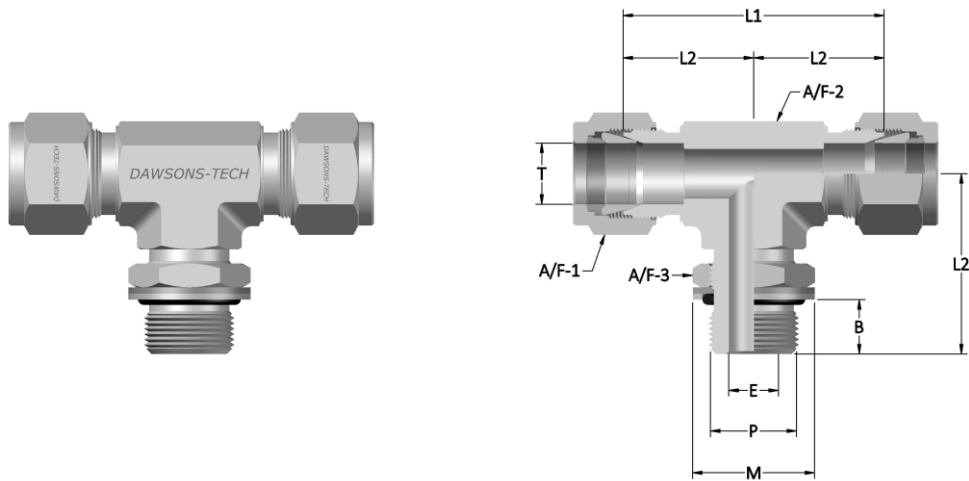

STANDARD CONFIGURATION DIMENSIONS

Tube OD	BSPP Male Thread	Dimension in mm						A/F1	A/F2	A/F3	Dawsons-Tech Part No.
		T	P	B	E	L1	L2				
6	1/8	8.1	4.0	39.1	19.6	26.4	17.3	9/16	1/2	9/16	DTPMBT-6M-2PR
6	1/4	9.1	4.8	43.2	21.6	32.3	22.9	9/16	5/8	3/4	DTPMBT-6M-4PR
8	1/8	8.1	4.0	42.7	21.3	27.4	17.3	5/8	9/16	9/16	DTPMBT-8M-2PR
8	1/4	9.1	6.4	44.7	22.4	32.2	22.9	5/8	5/8	3/4	DTPMBT-8M-4PR
10	1/4	9.1	5.9	51.8	25.9	35.0	22.9	3/4	13/16	3/4	DTPMBT-10M-4PR
12	3/8	9.4	7.9	51.8	25.9	37.1	26.4	7/8	13/16	7/8	DTPMBT-12M-6PR
12	1/2	13.4	9.5	55.9	27.9	43.4	32.0	7/8	15/16	1-1/16	DTPMBT-12M-8PR

Dimensions are for reference only and are subject to change

Positionable Male Run Tee (*Fractional* Tube to SAE / MS Straight Male Thread Boss Connection)

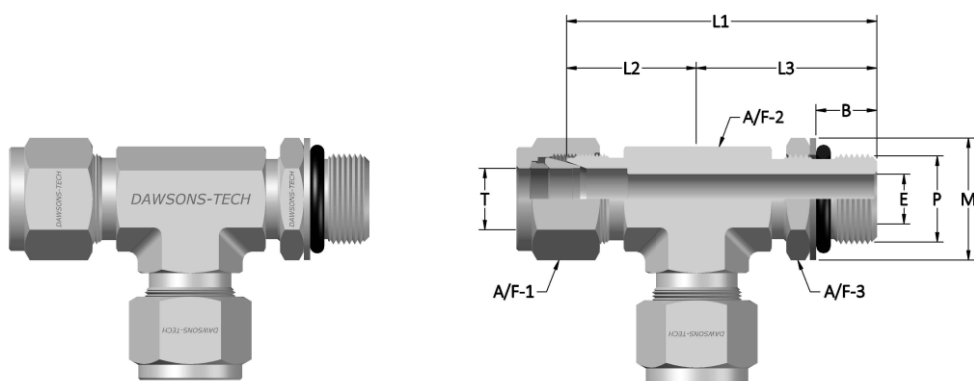

STANDARD CONFIGURATION DIMENSIONS

Tube OD	SAE / MS Straight Thread	Dimension in Inch									Dawsons-Tech Part No.
		T	P	B	E	L1	L2	L3	M	A/F1	
1/4	7/16 - 20	0.39	0.19	1.95	0.83	1.12	0.65	9/16	1/2	9/16	DTPMRT-4-7SE
3/8	9/16 - 18	0.44	0.28	2.24	0.97	1.27	0.79	11/16	5/8	11/16	DTPMRT-6-9SE
1/2	3/4 - 16	0.50	0.41	2.57	1.08	1.49	1.01	7/8	13/16	7/8	DTPMRT-8-12SE
3/4	1-1/16 - 12	0.66	0.62	3.15	1.23	1.92	1.44	1-1/8	1-1/16	1-1/4	DTPMRT-12-17SE
1	1-5/16 - 12	0.66	0.88	3.62	1.51	2.11	1.73	1-1/2	1-3/8	1-1/2	DTPMRT-16-21SE

Dimensions are for reference only and are subject to change

Positionable Male Run Tee (*Fractional* Tube to ISO Parallel (PR) Male Thread)

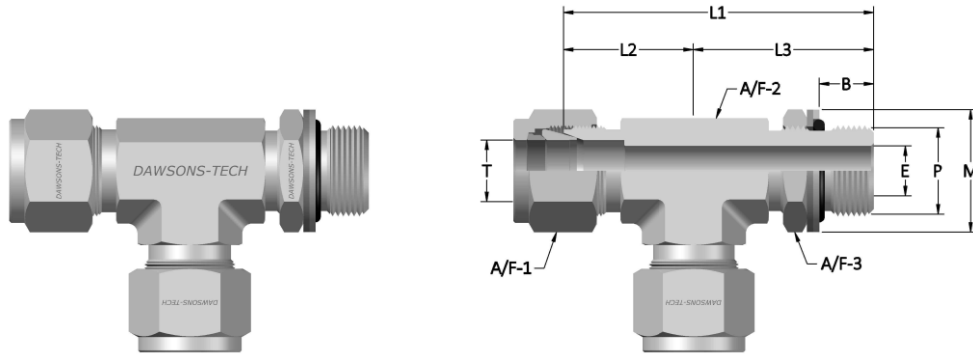

STANDARD CONFIGURATION DIMENSIONS

Tube OD	BSPP Male Thread	Dimension in Inch									Dawsons-Tech Part No.
T	P	B	E	L1	L2	L3	M	A/F1	A/F2	A/F3	
1/4	1/8	0.32	0.16	1.81	0.77	1.04	0.68	9/16	1/2	9/16	DTPMRT-4-2PR
1/4	1/4	0.36	0.19	2.21	0.85	1.27	0.90	9/16	5/8	3/4	DTPMRT-4-4PR
3/8	1/4	0.36	0.23	2.18	0.91	1.27	0.90	11/16	5/8	3/4	DTPMRT-6-4PR
1/2	3/8	0.37	0.31	2.48	1.02	1.46	1.04	7/8	13/16	7/8	DTPMRT-8-6PR
1/2	1/2	0.51	0.41	2.81	1.10	1.71	1.26	7/8	15/16	1-1/16	DTPMRT-8-8PR
5/8	1/2	0.51	0.47	2.81	1.10	1.71	1.26	1	15/16	1-1/16	DTPMRT-10-8PR
3/4	1/2	0.51	0.47	2.95	1.17	1.78	1.26	1-1/8	1-1/16	1-1/16	DTPMRT-12-8PR
3/4	3/4	0.51	0.62	3.09	1.17	1.92	1.62	1-1/8	1-1/16	1-3/8	DTPMRT-12-12PR
1	1	0.55	0.78	3.56	1.45	2.11	1.91	1-1/2	1-3/8	1-5/8	DTPMRT-16-16PR

Dimensions are for reference only and are subject to change

Positionable Male Run Tee (*Metric* Tube to ISO Parallel (PR) Male Thread)

Tube OD	BSPP Male Thread	Dimension in mm						A/F1	A/F2	A/F3	Dawsons-Tech Part No.
T	P	B	E	L1	L2	L3	M				
6	1/8	8.1	4.0	46.0	19.6	26.4	17.3	9/16	1/2	9/16	DTPMRT-6M-2PR
6	1/4	9.1	4.8	53.8	21.6	32.3	22.9	9/16	5/8	3/4	DTPMRT-6M-4PR
8	1/8	8.1	4.0	48.8	21.3	27.4	17.3	5/8	9/16	9/16	DTPMRT-8M-2PR
8	1/4	9.1	6.4	54.6	22.4	32.2	22.9	5/8	5/8	3/4	DTPMRT-8M-4PR
10	1/4	9.1	5.9	61.0	25.9	35.0	22.9	3/4	13/16	3/4	DTPMRT-10M-4PR
12	3/8	9.4	7.9	63.0	25.9	37.1	26.4	7/8	13/16	7/8	DTPMRT-12M-6PR
12	1/2	13.4	9.5	71.4	27.9	43.4	32.0	7/8	15/16	1-1/16	DTPMRT-12M-8PR

Dimensions are for reference only and are subject to change

Female Connector (*Fractional* Tube to NPT Female Thread)

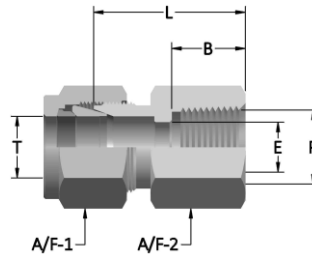
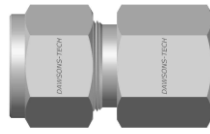

STANDARD CONFIGURATION DIMENSIONS

Tube OD	NPT Female Thread	Dimension in Inch					Dawsons-Tech Part No.
T	P	B	E	L	A/F1	A/F2	
1/8	1/8	0.41	0.09	0.87	7/16	9/16	DTFC-2-2N
1/8	1/4	0.59	0.09	1.06	7/16	3/4	DTFC-2-4N
3/16	1/8	0.39	0.12	0.91	1/2	9/16	DTFC-3-2N
1/4	1/8	0.39	0.19	0.94	9/16	9/16	DTFC-4-2N
1/4	1/4	0.59	0.19	1.12	9/16	3/4	DTFC-4-4N
1/4	3/8	0.59	0.19	1.19	9/16	7/8	DTFC-4-6N
1/4	1/2	0.78	0.19	1.38	9/16	1-1/16	DTFC-4-8N
5/16	1/8	0.41	0.25	0.97	5/8	9/16	DTFC-5-2N
5/16	1/4	0.59	0.25	1.16	5/8	3/4	DTFC-5-4N
5/16	3/8	0.59	0.25	1.22	5/8	7/8	DTFC-5-6N
3/8	1/8	0.41	0.28	1.00	11/16	5/8	DTFC-6-2N
3/8	1/4	0.59	0.28	1.19	11/16	3/4	DTFC-6-4N
3/8	3/8	0.59	0.28	1.25	11/16	7/8	DTFC-6-6N
3/8	1/2	0.78	0.28	1.44	11/16	1-1/16	DTFC-6-8N
3/8	3/4	0.81	0.28	1.59	11/16	1-5/16	DTFC-6-12N
1/2	1/4	0.59	0.41	1.19	7/8	13/16	DTFC-8-4N
1/2	3/8	0.59	0.41	1.25	7/8	7/8	DTFC-8-6N
1/2	1/2	0.78	0.41	1.44	7/8	1-1/16	DTFC-8-8N
1/2	3/4	0.81	0.41	1.50	7/8	1-5/16	DTFC-8-12N
5/8	3/8	0.59	0.50	1.25	1	15/16	DTFC-10-6N
5/8	1/2	0.78	0.50	1.44	1	1-1/16	DTFC-10-8N
5/8	3/4	0.81	0.50	1.50	1	1-5/16	DTFC-10-12N
3/4	1/2	0.78	0.62	1.44	1-1/8	1-1/16	DTFC-12-8N
3/4	3/4	0.81	0.62	1.50	1-1/8	1-5/16	DTFC-12-12N
7/8	3/4	0.81	0.72	1.56	1-1/4	1-5/16	DTFC-14-12N
1	3/4	0.81	0.88	1.62	1-1/2	1-3/8	DTFC-16-12N
1	1	1.00	0.88	1.97	1-1/2	1-5/8	DTFC-16-16N

Dimensions are for reference only and are subject to change

Female Connector (*Metric* Tube to NPT Female Thread)

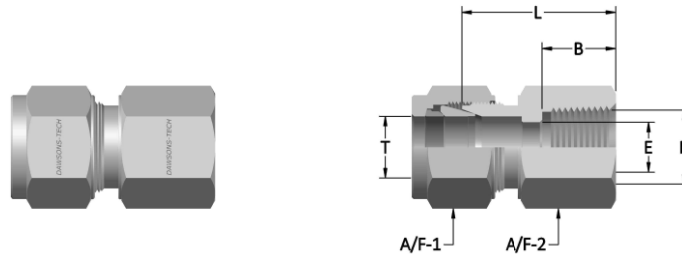

STANDARD CONFIGURATION DIMENSIONS

Tube OD	NPT Female Thread	Dimension in mm			A/F1	A/F2	Dawsons-Tech Part No.
		T	P	B			
3	1/8	10.4	2.4	22.1	7/16	9/16	DTFC-3M-2N
3	1/4	15.0	2.4	26.9	7/16	3/4	DTFC-3M-4N
4	1/8	10.4	2.4	23.1	1/2	9/16	DTFC-4M-2N
6	1/8	10.4	4.8	23.9	9/16	9/16	DTFC-6M-2N
6	1/4	15.0	4.8	28.4	9/16	3/4	DTFC-6M-4N
6	3/8	15.0	4.8	30.2	9/16	7/8	DTFC-6M-6N
6	1/2	19.8	4.8	35.1	9/16	1-1/16	DTFC-6M-8N
8	1/8	10.4	4.8	24.6	5/8	9/16	DTFC-8M-2N
8	1/4	15.0	6.4	29.5	5/8	3/4	DTFC-8M-4N
8	3/8	15.0	6.4	31.0	5/8	7/8	DTFC-8M-6N
8	1/2	19.8	6.4	35.8	5/8	1-1/16	DTFC-8M-8N
10	1/4	15.0	7.9	30.2	3/4	3/4	DTFC-10M-4N
10	3/8	15.0	7.9	31.8	3/4	7/8	DTFC-10M-6N
10	1/2	19.8	7.9	36.6	3/4	1-1/16	DTFC-10M-8N
12	1/4	15.0	9.5	30.2	7/8	7/8	DTFC-12M-4N
12	3/8	15.0	9.5	31.8	7/8	7/8	DTFC-12M-6N
12	1/2	19.8	9.5	36.6	7/8	1-1/16	DTFC-12M-8N
15	1/2	19.8	11.9	36.6	1	1-1/16	DTFC-15M-8N
16	1/2	19.8	12.7	36.8	1	1-1/16	DTFC-16M-8N
20	1/2	19.8	15.9	37.8	1-1/4	1-1/8	DTFC-20M-8N
20	3/4	20.6	15.9	39.6	1-1/4	1-3/8	DTFC-20M-12N
22	3/4	20.6	18.3	39.6	1-1/4	1-3/8	DTFC-22M-12N
22	1	25.4	18.3	47.8	1-1/4	1-5/8	DTFC-22M-16N
25	3/4	20.6	21.8	41.1	1-1/2	1-3/8	DTFC-25M-12N
25	1	25.4	21.8	50.0	1-1/2	1-5/8	DTFC-25M-16N

Dimensions are for reference only and are subject to change

Female Connector (*Fractional* to ISO BSP Taper (RT) Female Thread)

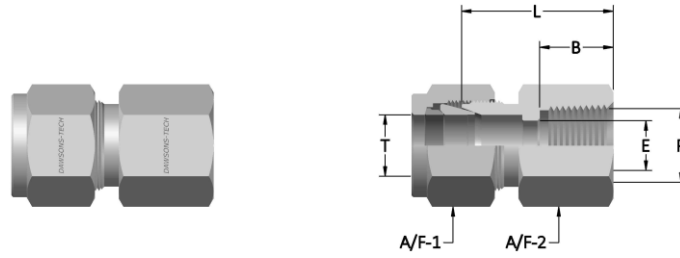

STANDARD CONFIGURATION DIMENSIONS

Tube OD	BSPT Female Thread	Dimension in Inch					Dawsons-Tech Part No.
T	P	B	E	L	A/F1	A/F2	
1/4	1/8	0.41	0.19	0.94	9/16	9/16	DTFC-4-2RT
1/4	1/4	0.59	0.19	1.12	9/16	3/4	DTFC-4-4RT
1/4	3/8	0.59	0.19	1.19	9/16	7/8	DTFC-4-6RT
1/4	1/2	0.78	0.19	1.38	9/16	1-1/16	DTFC-4-8RT
3/8	1/4	0.59	0.28	1.19	11/16	3/4	DTFC-6-4RT
3/8	3/8	0.59	0.28	1.25	11/16	7/8	DTFC-6-6RT
3/8	1/2	0.78	0.28	1.44	11/16	1-1/16	DTFC-6-8RT
1/2	1/4	0.59	0.41	1.19	7/8	13/16	DTFC-8-4RT
1/2	3/8	0.59	0.41	1.25	7/8	7/8	DTFC-8-6RT
1/2	1/2	0.78	0.41	1.44	7/8	1-1/16	DTFC-8-8RT

Dimensions are for reference only and are subject to change

Female Connector (*Metric* Tube to ISO BSP Taper (RT) Female Thread)

Tube OD	BSPT Female Thread	Dimension in mm			A/F1	A/F2	Dawsons-Tech Part No.
T	P	B	E	L			
3	1/8	10.4	2.4	22.1	7/16	9/16	DTFC-3M-2RT
6	1/8	10.4	4.8	23.9	9/16	9/16	DTFC-6M-2RT
6	1/4	15.0	4.8	28.4	9/16	3/4	DTFC-6M-4RT
6	3/8	15.0	4.8	30.2	9/16	7/8	DTFC-6M-6RT
6	1/2	19.8	4.8	35.1	9/16	1-1/16	DTFC-6M-8RT
8	1/8	10.4	6.4	24.6	5/8	9/16	DTFC-8M-2RT
8	1/4	15.0	6.4	29.5	5/8	3/4	DTFC-8M-4RT
8	3/8	15.0	6.4	31.0	5/8	7/8	DTFC-8M-6RT
8	1/2	19.8	6.4	35.8	5/8	1-1/16	DTFC-8M-8RT
10	1/8	10.4	7.9	25.4	3/4	11/16	DTFC-10M-2RT
10	1/4	15.0	7.9	30.2	3/4	3/4	DTFC-10M-4RT
10	3/8	15.0	7.9	31.8	3/4	7/8	DTFC-10M-6RT
10	1/2	19.8	7.9	36.6	3/4	1-1/16	DTFC-10M-8RT
12	1/8	10.4	8.3	25.4	7/8	7/8	DTFC-12M-2RT
12	1/4	15.0	9.5	30.2	7/8	7/8	DTFC-12M-4RT
12	3/8	15.0	9.5	31.8	7/8	7/8	DTFC-12M-6RT
12	1/2	19.8	9.5	36.6	7/8	1-1/16	DTFC-12M-8RT
12	3/4	20.6	9.5	38.9	7/8	1-3/8	DTFC-12M-12RT
15	3/8	15.0	11.9	31.8	1	15/16	DTFC-15M-6RT
15	1/2	19.8	11.9	36.6	1	1-1/16	DTFC-15M-8RT
20	1/2	19.8	15.9	37.8	1-1/4	1-1/8	DTFC-20M-8RT
20	3/4	20.6	15.9	39.6	1-1/4	1-3/8	DTFC-20M-12RT
22	3/4	20.6	18.3	39.6	1-1/4	1-3/8	DTFC-22M-12RT
22	1	25.4	18.3	47.8	1-1/4	1-5/8	DTFC-22M-16RT
25	3/4	20.6	21.8	41.1	1-1/2	1-3/8	DTFC-25M-12RT
25	1	25.4	21.8	50.0	1-1/2	1-5/8	DTFC-25M-16RT

Dimensions are for reference only and are subject to change

Female Connector (*Fractional* Tube to ISO Parallel (RG) Female Thread)

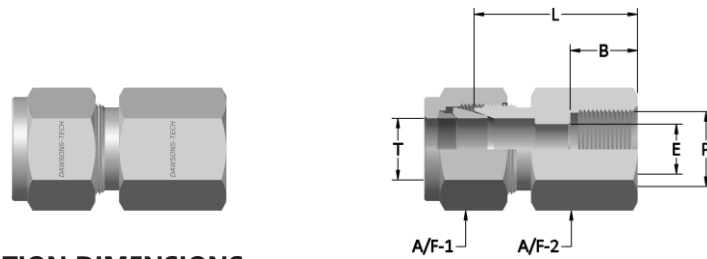

STANDARD CONFIGURATION DIMENSIONS

Tube OD	BSPP Female Thread	Dimension in Inch					Dawsons-Tech Part No.
T	P	B	E	L	A/F1	A/F2	
1/4	1/4	0.51	0.19	1.19	9/16	3/4	DTFC-4-4RG
1/4	3/8	0.56	0.19	1.19	9/16	7/8	DTFC-4-6RG
1/4	1/2	0.74	0.19	1.42	9/16	1-1/16	DTFC-4-8RG
5/16	1/4	0.51	0.22	1.22	5/8	3/4	DTFC-5-4RG
5/16	1/2	0.74	0.28	1.32	5/8	1-1/16	DTFC-5-8RG
3/8	1/4	0.51	0.22	1.25	11/16	3/4	DTFC-6-4RG
3/8	3/8	0.56	0.26	1.23	11/16	7/8	DTFC-6-6RG
3/8	1/2	0.74	0.28	1.36	11/16	1-1/16	DTFC-6-8RG
1/2	3/8	0.56	0.26	1.35	7/8	7/8	DTFC-8-6RG
1/2	1/2	0.74	0.28	1.50	7/8	1-1/16	DTFC-8-8RG

Dimensions are for reference only and are subject to change

Female Connector (*Metric* Tube to ISO Parallel (RG) Female Thread)

Tube OD	BSPP Female Thread	Dimension in mm			A/F1	A/F2	Dawsons-Tech Part No.
T	P	B	E	L			
3	1/4	12.9	2.4	28.7	7/16	3/4	DTFC-3M-4RG
6	1/4	12.9	4.8	30.2	9/16	3/4	DTFC-6M-4RG
6	3/8	14.1	4.8	30.2	9/16	7/8	DTFC-6M-6RG
6	1/2	18.9	4.8	36.1	9/16	1-1/16	DTFC-6M-8RG
8	1/4	12.9	5.5	31.0	5/8	3/4	DTFC-8M-4RG
8	3/8	14.1	6.5	33.3	5/8	7/8	DTFC-8M-6RG
8	1/2	18.9	7.0	36.5	5/8	1-1/16	DTFC-8M-8RG
10	1/4	12.9	5.5	31.8	3/4	3/4	DTFC-10M-4RG
10	3/8	14.1	6.5	31.2	3/4	7/8	DTFC-10M-6RG
10	1/2	18.9	7.0	34.5	3/4	1-1/16	DTFC-10M-8RG
12	1/4	12.9	5.5	31.8	7/8	7/8	DTFC-12M-4RG
12	3/8	14.1	6.5	34.3	7/8	7/8	DTFC-12M-6RG
12	1/2	18.9	7.0	38.1	7/8	1-1/16	DTFC-12M-8RG
20	1/2	18.9	7.0	44.2	1-1/4	1-1/8	DTFC-20M-8RG
22	1/2	18.9	7.0	44.2	1-1/4	1-1/8	DTFC-22M-8RG

Dimensions are for reference only and are subject to change

Bulkhead Female Connector (*Fractional* Tube to NPT Female Thread)

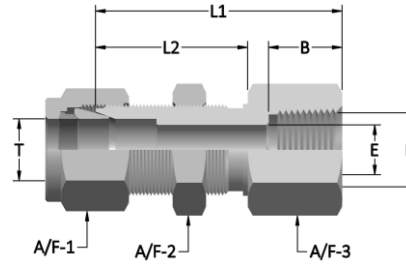
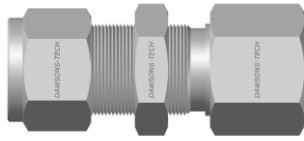

STANDARD CONFIGURATION DIMENSIONS

Tube OD T	NPT Female Thread P	Dimension in Inch							Panel Hole Size	Max. Panel Thickness	Dawsons-Tech Part No.
		B	E	L1	L2	A/F1	A/F2	A/F3			
1/8	1/8	0.41	0.09	1.50	0.97	7/16	9/16	9/16	21/64	0.50	DTBFC-2-2N
3/16	1/8	0.41	0.12	1.53	1.00	1/2	9/16	9/16	25/64	0.50	DTBFC-3-2N
1/4	1/8	0.41	0.19	1.56	1.02	9/16	5/8	5/8	29/64	0.40	DTBFC-4-2N
1/4	1/4	0.59	0.19	1.75	1.02	9/16	3/4	3/4	29/64	0.40	DTBFC-4-4N
5/16	1/8	0.41	0.25	1.66	1.12	5/8	11/16	11/16	33/64	0.44	DTBFC-5-2N
3/8	1/4	0.59	0.28	1.88	1.15	11/16	3/4	3/4	37/64	0.44	DTBFC-6-4N
1/2	3/8	0.59	0.41	2.03	1.25	7/8	15/16	15/16	49/64	0.50	DTBFC-8-6N
1/2	1/2	0.78	0.41	2.22	1.25	7/8	1-1/16	15/16	49/64	0.50	DTBFC-8-8N
5/8	1/2	0.78	0.50	2.25	1.28	1	1-1/16	1-1/16	57/64	0.50	DTBFC-10-8N
3/4	3/4	0.81	0.62	2.50	1.47	1-1/8	1-3/8	1-3/16	1-1/64	0.66	DTBFC-12-12N
7/8	3/4	0.81	0.72	2.78	1.69	1-1/4	1-3/8	1-3/8	1-9/64	0.66	DTBFC-14-12N
1	1	1.00	0.88	3.19	1.78	1-1/2	1-5/8	1-5/8	1-21/64	0.75	DTBFC-16-16N

Dimensions are for reference only and are subject to change

Bulkhead Female Connector (*Metric* Tube to NPT Female Thread)

Tube OD T	NPT Male Thread P	Dimension in mm				A/F1	A/F2	A/F3	Panel Hole Size	Max. Panel Thickness	Dawsons-Tech Part No.
		B	E	L1	L2						
6	1/8	10.4	4.8	39.7	26.2	9/16	5/8	5/8	11.5	10.2	DTBFC-6M-2N
6	1/4	15.0	4.8	44.5	26.2	9/16	3/4	5/8	11.5	10.2	DTBFC-6M-4N
8	1/8	10.4	6.4	42.1	28.5	5/8	11/16	11/16	13.1	11.2	DTBFC-8M-2N
10	1/4	15.0	7.1	47.6	29.4	3/4	3/4	3/4	16.3	11.2	DTBFC-10M-4N
12	3/8	15.0	10.4	50.8	31.8	7/8	15/16	15/16	19.5	12.7	DTBFC-12M-6N
12	1/2	19.8	10.4	56.3	31.8	7/8	15/16	15/16	19.5	12.7	DTBFC-12M-8N

Dimensions are for reference only and are subject to change

Female Elbow (*Fractional* Tube to NPT Female Thread)

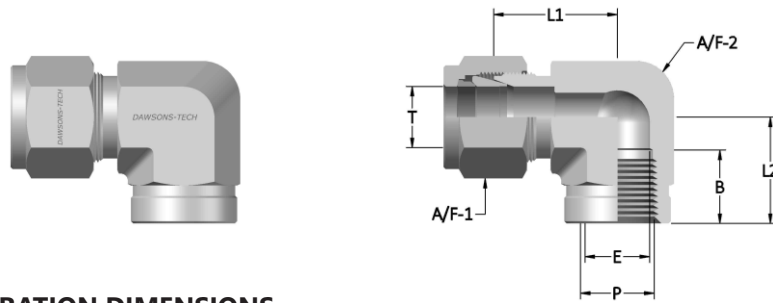

STANDARD CONFIGURATION DIMENSIONS

Tube OD	NPT Female Thread	Dimension in Inch						Dawsons-Tech Part No.
T	P	B	E	L1	L2	A/F1	A/F2	
1/8	1/8	0.41	0.09	0.71	0.75	7/16	9/16	DTFE-2-2N
1/8	1/4	0.59	0.09	0.82	0.88	7/16	3/4	DTFE-2-4N
3/16	1/8	0.41	0.12	0.74	0.75	1/2	9/16	DTFE-3-2N
1/4	1/8	0.41	0.19	0.77	0.75	9/16	9/16	DTFE-4-2N
1/4	1/4	0.59	0.19	0.88	0.88	9/16	3/4	DTFE-4-4N
1/4	3/8	0.59	0.19	0.96	0.88	9/16	7/8	DTFE-4-6N
1/4	1/2	0.78	0.19	1.07	1.12	9/16	1-1/16	DTFE-4-8N
5/16	1/8	0.41	0.25	0.84	0.75	5/8	9/16	DTFE-5-2N
5/16	1/4	0.59	0.25	0.91	0.88	5/8	3/4	DTFE-5-4N
3/8	1/8	0.41	0.28	0.91	0.75	11/16	5/8	DTFE-6-2N
3/8	1/4	0.59	0.28	0.94	0.88	11/16	3/4	DTFE-6-4N
3/8	3/8	0.59	0.28	1.02	0.88	11/16	7/8	DTFE-6-6N
3/8	1/2	0.78	0.28	1.13	1.12	11/16	1-1/16	DTFE-6-8N
1/2	1/4	0.59	0.41	1.02	0.88	7/8	13/16	DTFE-8-4N
1/2	3/8	0.59	0.41	1.02	0.88	7/8	7/8	DTFE-8-6N
1/2	1/2	0.78	0.41	1.13	1.12	7/8	1-1/16	DTFE-8-8N
5/8	3/8	0.59	0.50	1.10	0.88	1	15/16	DTFE-10-6N
5/8	1/2	0.78	0.50	1.17	1.12	1	1-1/16	DTFE-10-8N
3/4	1/2	0.78	0.62	1.17	1.12	1-1/8	1-1/8	DTFE-12-8N
3/4	3/4	0.81	0.62	1.36	1.25	1-1/8	1-3/8	DTFE-12-12N
7/8	3/4	0.81	0.72	1.36	1.25	1-1/4	1-3/8	DTFE-14-12N
1	3/4	0.81	0.88	1.45	1.25	1-1/2	1-3/8	DTFE-16-12N
1	1	1.00	0.88	1.63	1.50	1-1/2	1-5/8	DTFE-16-16N

Dimensions are for reference only and are subject to change

Female Elbow (*Metric* Tube to NPT Female Thread)

Tube OD	NPT Female Thread	Dimension in mm				A/F1	A/F2	Dawsons-Tech Part No.
T	P	B	E	L1	L2			
6	1/8	10.4	4.8	19.6	19.0	9/16	9/16	DTFE-6M-2N
6	1/4	15.0	4.8	22.4	22.4	9/16	3/4	DTFE-6M-4N
6	1/2	19.8	4.8	27.2	28.4	9/16	1-1/16	DTFE-6M-8N
8	1/4	15.0	6.4	23.1	22.4	5/8	3/4	DTFE-8M-4N
10	1/8	10.4	7.9	23.9	19.0	3/4	11/16	DTFE-10M-4N
10	1/4	15.0	7.9	25.9	22.4	3/4	13/16	DTFE-10M-4N
12	1/4	15.0	9.5	25.9	22.4	7/8	13/16	DTFE-12M-4N
12	3/8	15.0	9.5	25.9	22.4	7/8	7/8	DTFE-12M-6N
12	1/2	19.8	9.5	28.7	28.4	7/8	1-1/16	DTFE-12M-8N
16	1/2	12.7	12.7	29.7	28.4	1	1-1/16	DTFE-16M-8N

Dimensions are for reference only and are subject to change

Female Branch Tee (*Fractional* Tube to NPT Female Thread)

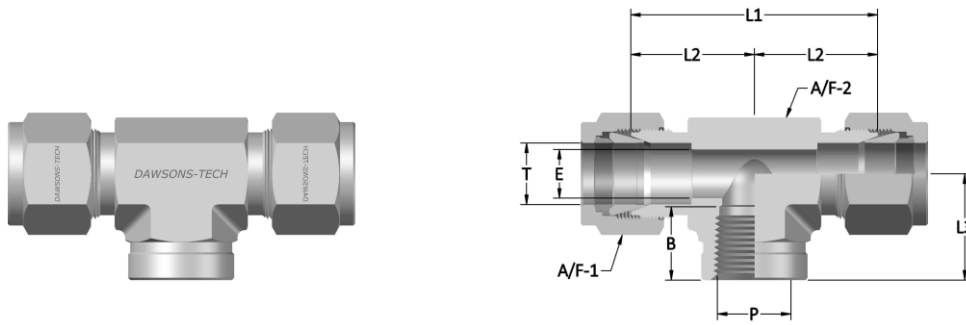

STANDARD CONFIGURATION DIMENSIONS

Tube OD	NPT Female Thread	Dimension in Inch							Dawsons-Tech Part No.
		T	P	B	E	L1	L2	L3	
1/8	1/8	0.41	0.09	1.42	0.71	0.75	7/16	9/16	DTFBT-2-2N
1/4	1/8	0.41	0.19	1.54	0.77	0.75	9/16	9/16	DTFBT-4-2N
1/4	1/4	0.59	0.19	1.76	0.88	0.88	9/16	3/4	DTFBT-4-4N
3/8	1/4	0.59	0.28	1.88	0.94	0.88	11/16	3/4	DTFBT-6-4N
3/8	3/8	0.59	0.28	2.04	1.02	0.88	11/16	7/8	DTFBT-6-6N
3/8	1/2	0.78	0.28	2.26	1.13	1.12	11/16	1-1/16	DTFBT-6-8N
1/2	1/4	0.59	0.41	2.04	1.02	0.88	7/8	13/16	DTFBT-8-4N
1/2	3/8	0.59	0.41	2.04	1.02	0.88	7/8	7/8	DTFBT-8-6N
1/2	1/2	0.78	0.41	2.26	1.13	1.12	7/8	1-1/16	DTFBT-8-8N
5/8	1/2	0.78	0.50	2.26	1.13	1.12	1	1-1/16	DTFBT-10-8N
3/4	3/4	0.81	0.62	2.72	1.36	1.25	1-1/8	1-3/8	DTFBT-12-12N
1	3/4	0.81	0.88	2.90	1.45	1.25	1-1/2	1-3/8	DTFBT-16-12N
1	1	1.00	0.88	3.26	1.63	1.50	1-1/2	1-5/8	DTFBT-16-16N

Dimensions are for reference only and are subject to change

Female Branch Tee (*Metric* Tube to NPT Female Thread)

Tube OD	NPT Female Thread	Dimension in mm					A/F1	A/F2	Dawsons-Tech Part No.
		T	P	B	E	L1			
6	1/8	10.4	4.8	39.1	19.6	19.0	9/16	9/16	DTFBT-6M-2N
6	1/4	15.0	4.8	44.7	22.4	22.4	9/16	3/4	DTFBT-6M-4N
8	1/8	10.4	6.4	44.7	22.4	19.0	5/8	5/8	DTFBT-8M-2N
8	1/4	15.0	6.4	46.2	23.1	22.4	5/8	3/4	DTFBT-8M-4N
10	1/4	15.0	7.9	51.8	25.9	22.4	3/4	3/4	DTFBT-10M-4N
12	1/4	15.0	9.5	51.8	25.9	22.4	7/8	13/16	DTFBT-12M-4N
12	3/8	15.0	9.5	51.8	25.9	22.4	7/8	7/8	DTFBT-12M-6N
16	1/2	19.8	12.7	57.4	28.7	28.4	1	1-1/16	DTFBT-16M-8N

Dimensions are for reference only and are subject to change

Female Run Tee (*Fractional* Tube to NPT Female Thread)

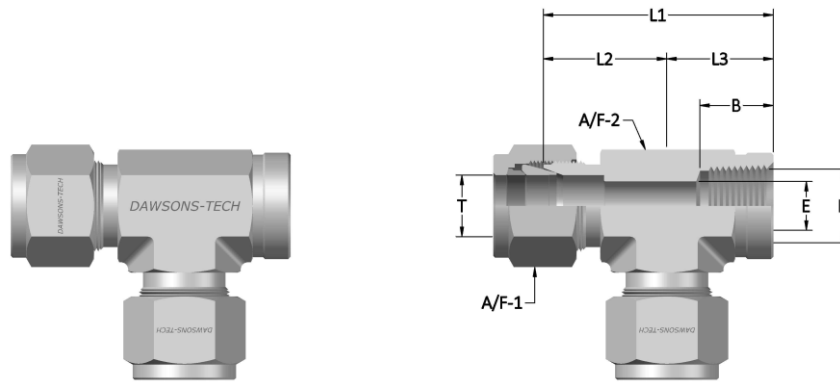

STANDARD CONFIGURATION DIMENSIONS

Tube OD	NPT Female Thread	Dimension in Inch							Dawsons-Tech Part No.
		T	P	B	E	L1	L2	L3	
1/8	1/8	0.41	0.09	1.46	0.71	0.71	7/16	9/16	DTFRT-2-2N
1/4	1/8	0.41	0.19	1.52	0.77	0.75	9/16	9/16	DTFRT-4-2N
1/4	1/4	0.59	0.19	1.76	0.88	0.88	9/16	3/4	DTFRT-4-4N
3/8	1/4	0.59	0.28	1.82	0.94	0.88	11/16	3/4	DTFRT-6-4N
1/2	3/8	0.59	0.41	1.90	1.02	0.88	7/8	7/8	DTFRT-8-6N
1/2	1/2	0.78	0.41	2.29	1.17	1.12	7/8	1-1/16	DTFRT-8-8N
3/4	3/4	0.81	0.62	2.61	1.36	1.25	1-1/8	1-3/8	DTFRT-12-12N
1	3/4	0.81	0.88	2.70	1.45	1.25	1-1/2	1-3/8	DTFRT-16-12N
1	1	1.00	0.88	3.13	1.63	1.50	1-1/2	1-5/8	DTFRT-16-16N

Dimensions are for reference only and are subject to change

Female Run Tee (*Metric* Tube to NPT Female Thread)

Tube OD	NPT Female Thread	Dimension in mm					A/F1	A/F2	Dawsons-Tech Part No.
		B	E	L1	L2	L3			
6	1/8	10.4	4.8	38.6	19.6	19.0	9/16	9/16	DTFBT-6M-2N
6	1/4	15.0	4.8	44.7	22.4	22.4	9/16	3/4	DTFBT-6M-4N
8	1/8	10.4	6.4	41.4	22.4	19.0	5/8	5/8	DTFBT-8M-2N
8	1/4	15.0	6.4	45.5	23.1	22.4	5/8	3/4	DTFBT-8M-4N
10	1/4	15.0	7.9	48.3	25.9	22.4	3/4	13/16	DTFBT-10M-4N
12	1/4	15.0	9.5	48.3	25.9	22.4	7/8	13/16	DTFBT-12M-4N
12	3/8	15.0	10.3	48.3	25.9	22.4	7/8	7/8	DTFBT-12M-6N
16	1/2	19.8	12.7	58.1	29.7	28.4	1	1-1/16	DTFBT-16M-8N

Dimensions are for reference only and are subject to change

Union (*Fractional* Tube)

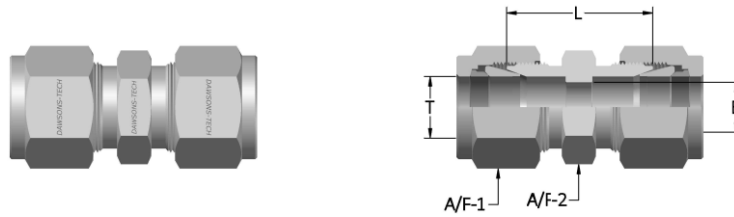

STANDARD CONFIGURATION DIMENSIONS

Tube OD	Dimension in Inch				Dawsons-Tech Part No.
	T	E	L	A/F1	
1/8	0.09	0.88	7/16	7/16	DTU-2
3/16	0.12	0.95	1/2	7/16	DTU-3
1/4	0.19	1.03	9/16	1/2	DTU-4
5/16	0.25	1.11	5/8	9/16	DTU-5
3/8	0.28	1.19	11/16	5/8	DTU-6
1/2	0.41	1.22	7/8	13/16	DTU-8
5/8	0.50	1.25	1	15/16	DTU-10
3/4	0.62	1.31	1-1/8	1-1/16	DTU-12
7/8	0.72	1.37	1-1/4	1-3/16	DTU-14
1	0.88	1.59	1-1/2	1-3/8	DTU-16

Dimensions are for reference only and are subject to change

Union (*Metric* Tube)

Tube OD	Dimension in mm		A/F1	A/F2	Dawsons-Tech Part No.
	E	L			
3	2.4	22.1	7/16	7/16	DTU-3M
4	2.4	24.1	1/2	1/2	DTU-4M
6	4.8	26.2	9/16	9/16	DTU-6M
8	6.4	28.2	5/8	5/8	DTU-8M
10	7.9	31.0	3/4	11/16	DTU-10M
12	9.5	31.0	7/8	7/8	DTU-12M
14	11.1	31.8	1	15/16	DTU-14M
15	11.9	31.8	1	15/16	DTU-15M
16	12.7	31.8	1	15/16	DTU-16M
18	15.1	33.3	1-1/8	1-1/16	DTU-18M
20	15.9	34.8	1-1/4	1-1/8	DTU-20M
22	18.3	34.8	1-1/4	1-1/8	DTU-22M
25	21.8	40.4	1-1/2	1-3/8	DTU-25M

Dimensions are for reference only and are subject to change

Union (*Metric* Tube to *Fractional* Tube)

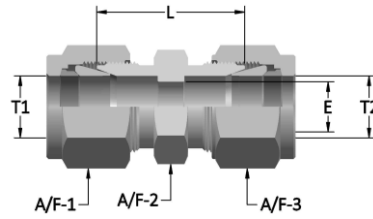

STANDARD CONFIGURATION DIMENSIONS

Tube OD (mm)	Tube OD (Inch)	Dimension in mm		A/F1	A/F2	A/F3	Dawsons-Tech Part No.
		E	L				
T1	T2						
3	1/8	2.4	22.1	7/16	7/16	7/16	DTU-3M-2
4	1/8	2.4	23.4	1/2	7/16	7/16	DTU-4M-2
4	1/4	2.4	25.4	1/2	9/16	1/2	DTU-4M-4
6	1/8	2.4	24.6	9/16	7/16	9/16	DTU-6M-2
6	1/4	4.8	26.2	9/16	9/16	9/16	DTU-6M-4
6	5/16	4.8	27.4	9/16	5/8	9/16	DTU-6M-5
8	1/4	4.8	27.4	5/8	9/16	5/8	DTU-8M-4
8	3/8	6.4	29.5	5/8	11/16	5/8	DTU-8M-6
10	1/8	2.4	27.7	3/4	7/16	11/16	DTU-10M-2
10	1/4	4.8	29.5	3/4	9/16	11/16	DTU-10M-4
10	5/16	6.4	30.0	3/4	5/8	11/16	DTU-10M-5
10	3/8	7.1	31.0	3/4	11/16	11/16	DTU-10M-6
12	5/16	6.4	30.2	7/8	5/8	7/8	DTU-12M-5
12	3/8	7.1	31.0	7/8	11/16	7/8	DTU-12M-6
12	1/2	9.5	31.0	7/8	7/8	7/8	DTU-12M-8
15	1/2	10.3	31.8	1	7/8	15/16	DTU-15M-8
16	5/8	12.7	31.8	1	1	15/16	DTU-16M-10
18	3/4	15.1	33.3	1-1/8	1-1/8	1-1/16	DTU-18M-12
20	1/2	10.3	34.8	1-1/4	7/8	1-1/8	DTU-20M-8
20	1	15.9	40.4	1-1/4	1-1/2	1-3/8	DTU-20M-16
25	1	21.8	40.4	1-1/2	1-1/2	1-3/8	DTU-25M-16

Dimensions are for reference only and are subject to change

Reducing Union (*Fractional* Tube)

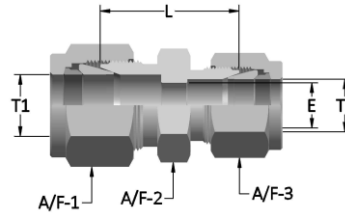
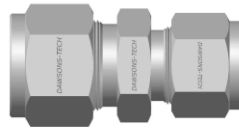

STANDARD CONFIGURATION DIMENSIONS

Tube OD	Reduced Tube OD	Dimension in Inch					Dawsons-Tech Part No.
T1	T2	E	L	A/F1	A/F2	A/F3	
3/16	1/8	0.09	0.92	1/2	7/16	7/16	DTRU-3-2
1/4	1/8	0.09	0.97	9/16	7/16	1/2	DTRU-4-2
1/4	3/16	0.12	1.00	9/16	1/2	1/2	DTRU-4-3
5/16	1/8	0.09	1.01	5/8	7/16	9/16	DTRU-5-2
5/16	1/4	0.19	1.08	5/8	9/16	9/16	DTRU-5-4
3/8	1/8	0.09	1.06	11/16	7/16	5/8	DTRU-6-2
3/8	1/4	0.19	1.12	11/16	9/16	5/8	DTRU-6-4
3/8	5/16	0.25	1.16	11/16	5/8	5/8	DTRU-6-5
1/2	1/8	0.09	1.12	7/8	7/16	13/16	DTRU-8-2
1/2	1/4	0.19	1.16	7/8	9/16	13/16	DTRU-8-4
1/2	3/8	0.28	1.22	7/8	11/16	13/16	DTRU-8-6
5/8	1/4	0.28	1.25	1	11/16	15/16	DTRU-10-4
5/8	1/2	0.41	1.25	1	7/8	15/16	DTRU-10-8
3/4	1/4	0.19	1.25	1-1/8	9/16	1-1/16	DTRU-12-4
3/4	3/8	0.28	1.31	1-1/8	11/16	1-1/16	DTRU-12-6
3/4	1/2	0.41	1.31	1-1/8	7/8	1-1/16	DTRU-12-8
3/4	5/8	0.50	1.31	1-1/8	1	1-1/16	DTRU-12-10
1	1/2	0.41	1.50	1-1/2	7/8	1-3/8	DTRU-16-8
1	3/4	0.62	1.50	1-1/2	1-1/8	1-3/8	DTRU-16-12

Dimensions are for reference only and are subject to change

Reducing Union (*Metric* Tube)

Tube OD	Reduced Tube OD	Dimension in mm		A/F1	A/F2	A/F3	Dawsons-Tech Part No.
T1	T2	E	L				
6	3	2.4	24.6	9/16	1/2	7/16	DTRU-6M-3M
6	4	2.4	25.4	9/16	1/2	1/2	DTRU-6M-4M
8	6	4.8	27.4	5/8	9/16	9/16	DTRU-8M-6M
10	6	4.8	29.5	3/4	7/16	9/16	DTRU-10M-6M
10	8	6.4	30.0	3/4	5/8	5/8	DTRU-10M-8M
12	6	4.8	29.5	7/8	9/16	9/16	DTRU-12M-6M
12	8	6.4	30.2	7/8	5/8	5/8	DTRU-12M-8M
12	10	7.9	31.0	7/8	3/4	3/4	DTRU-12M-10M
16	10	7.9	31.8	1	3/4	3/4	DTRU-16M-10M
16	12	9.5	31.8	1	7/8	7/8	DTRU-16M-12M
18	12	9.5	33.3	1-1/8	7/8	7/8	DTRU-18M-12M
25	18	15.1	38.6	1-1/2	1-1/8	1-1/8	DTRU-25M-18M
25	20	15.9	39.9	1-1/2	1-1/4	1-1/4	DTRU-25M-20M

Dimensions are for reference only and are subject to change

Bulkhead Union (*Fractional* Tube)

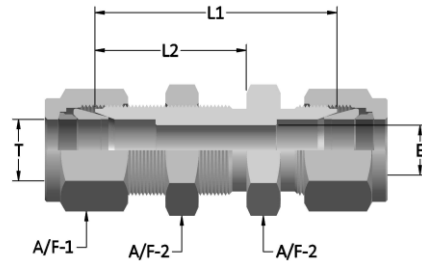
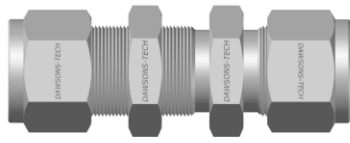

STANDARD CONFIGURATION DIMENSIONS

Tube OD	Dimension in Inch					Panel Hole Size	Max. Panel Thickness	Dawsons-Tech Part No.
T	E	L1	L2	A/F1	A/F2			
1/8	0.09	1.50	0.97	7/16	1/2	21/64	0.50	DTBU-2
3/16	0.12	1.59	1.00	1/2	9/16	25/64	0.50	DTBU-3
1/4	0.19	1.69	1.03	9/16	5/8	29/64	0.40	DTBU-4
5/16	0.25	1.81	1.12	5/8	11/16	33/64	0.44	DTBU-5
3/8	0.28	1.87	1.16	11/16	3/4	37/64	0.44	DTBU-6
1/2	0.41	2.00	1.25	7/8	15/16	49/64	0.50	DTBU-8
5/8	0.50	2.06	1.28	1	1-1/16	57/64	0.50	DTBU-10
3/4	0.62	2.31	1.47	1-1/8	1-3/16	1-1/64	0.66	DTBU-12
1	0.88	2.81	1.78	1-1/2	1-5/8	1-21/64	0.75	DTBU-16

Dimensions are for reference only and are subject to change

Bulkhead Union (*Metric* Tube)

Tube OD	Dimension in mm			A/F1	A/F2	Panel Hole Size	Max. Panel Thickness	Dawsons-Tech Part No.
T	E	L1	L2					
3	2.4	38.1	24.6	7/16	7/16	8.3	12.7	DTBU-3M
4	2.4	40.4	25.4	1/2	1/2	9.9	12.7	DTBU-4M
6	4.8	42.9	26.2	9/16	9/16	11.5	10.2	DTBU-6M
8	6.4	46.0	28.6	5/8	5/8	13.1	11.2	DTBU-8M
10	7.9	48.5	29.4	3/4	3/4	16.3	11.2	DTBU-10M
12	9.5	50.8	31.8	7/8	7/8	19.5	12.7	DTBU-12M
14	11.1	52.3	32.5	1	1	22.5	12.7	DTBU-14M
15	11.9	52.3	32.5	1	1	22.8	12.7	DTBU-15M
16	12.7	52.3	32.5	1	1	22.8	12.7	DTBU-16M
18	15.1	58.7	37.3	1-1/8	1-3/16	26.0	16.8	DTBU-18M
20	15.9	64.3	42.9	1-1/4	1-1/4	29.0	19.0	DTBU-20M
25	21.8	71.4	42.2	1-1/2	1-1/2	33.8	24.0	DTBU-25M

Dimensions are for reference only and are subject to change

Reducing Bulkhead Union (*Fractional* Tube)

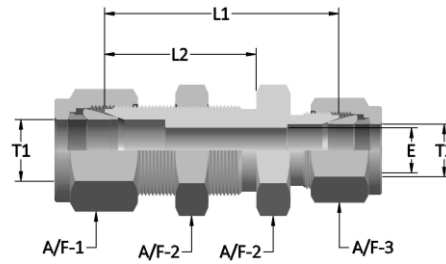
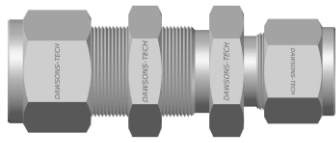

STANDARD CONFIGURATION DIMENSIONS

Tube OD	Reducing Tube OD	Dimension in Inch						Panel Hole Size	Max. Panel Thickness	Dawsons-Tech Part No.
		T1	T2	E	L1	L2	A/F1			
1/4	1/8	0.09	1.62	1.03	9/16	7/16	5/8	29/64	0.40	DTRBU-4-2
3/8	1/4	0.19	1.81	1.16	11/16	9/16	3/4	37/64	0.44	DTRBU-6-4
1/2	1/4	0.19	1.94	1.25	7/8	9/16	15/16	49/64	0.50	DTRBU-8-4

Dimensions are for reference only and are subject to change

Union Elbow (*Fractional* Tube)

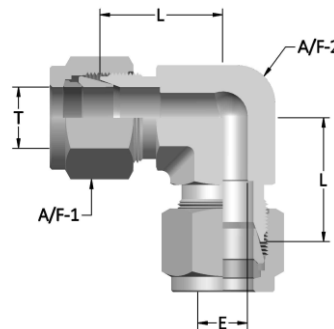

STANDARD CONFIGURATION DIMENSIONS

Tube OD	Dimension in Inch					Dawsons-Tech Part No.
	T	E	L	A/F1	A/F2	
1/8	0.09	0.62	7/16	7/16	DTUE-2	
3/16	0.12	0.74	1/2	7/16	DTUE-3	
1/4	0.19	0.77	9/16	1/2	DTUE-4	
5/16	0.25	0.84	5/8	9/16	DTUE-5	
3/8	0.28	0.91	11/16	5/8	DTUE-6	
1/2	0.41	1.02	7/8	13/16	DTUE-8	
5/8	0.50	1.10	1	15/16	DTUE-10	
3/4	0.62	1.17	1-1/8	1-1/16	DTUE-12	
7/8	0.72	1.36	1-1/4	1-3/16	DTUE-14	
1	0.88	1.45	1-1/2	1-3/8	DTUE-16	

Dimensions are for reference only and are subject to change

Union Elbow (*Metric* Tube)

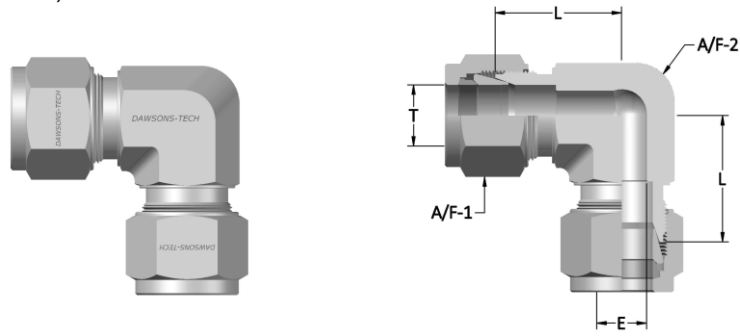

STANDARD CONFIGURATION DIMENSIONS

Tube OD	Dimension in mm		A/F1	A/F2	Dawsons-Tech Part No.
	T	E			
3	2.4	15.7	7/16	7/16	DTUE-3M
4	2.4	18.8	1/2	7/16	DTUE-4M
6	4.8	19.6	9/16	1/2	DTUE-6M
8	6.4	21.3	5/8	9/16	DTUE-8M
10	7.9	23.9	3/4	11/16	DTUE-10M
12	9.5	25.9	7/8	13/16	DTUE-12M
14	11.1	27.9	1	15/16	DTUE-14M
15	11.9	27.9	1	15/16	DTUE-15M
16	12.7	27.9	1	15/16	DTUE-16M
18	15.1	29.7	1-1/8	1-1/16	DTUE-18M
20	15.9	34.5	1-1/4	1-3/8	DTUE-20M
22	18.3	34.5	1-1/4	1-3/8	DTUE-22M
25	21.8	36.8	1-1/2	1-3/8	DTUE-25M

Dimensions are for reference only and are subject to change

Reducing Union Elbow (*Fractional* Tube)

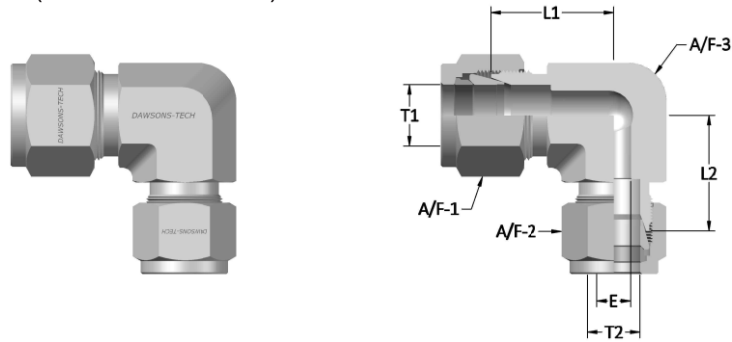

STANDARD CONFIGURATION DIMENSIONS

Tube OD	Reduced Tube OD	Dimension in Inch						Dawsons-Tech Part No.
T1	T2	E	L1	L2	A/F1	A/F2	A/F3	
3/16	1/8	0.09	0.69	0.66	1/2	7/16	7/16	DTRUE-3-2
1/4	1/8	0.09	0.77	0.70	9/16	7/16	1/2	DTRUE-4-2
5/16	1/8	0.09	0.88	0.78	5/8	7/16	5/8	DTRUE-5-2
5/16	1/4	0.19	0.88	0.85	5/8	9/16	5/8	DTRUE-5-4
3/8	1/8	0.09	0.91	0.78	11/16	7/16	5/8	DTRUE-6-2
3/8	1/4	0.19	0.91	0.85	11/16	9/16	5/8	DTRUE-6-4
3/8	5/16	0.25	0.91	0.88	11/16	5/8	5/8	DTRUE-6-5
1/2	1/4	0.09	1.02	0.96	7/8	9/16	13/16	DTRUE-8-4
1/2	5/16	0.19	1.02	0.99	7/8	5/8	13/16	DTRUE-8-5
1/2	3/8	0.28	1.02	1.02	7/8	11/16	13/16	DTRUE-8-6
5/8	3/8	0.28	1.03	1.03	1	11/16	7/8	DTRUE-10-6
5/8	1/2	0.41	1.03	1.03	1	7/8	7/8	DTRUE-10-8
3/4	1/4	0.19	1.16	1.09	1-1/8	9/16	1-1/16	DTRUE-12-4
3/4	3/8	0.28	1.16	1.16	1-1/8	11/16	1-1/16	DTRUE-12-6
3/4	1/2	0.41	1.16	1.16	1-1/8	7/8	1-1/16	DTRUE-12-8
7/8	1/4	0.19	1.36	1.22	1-1/4	9/16	1-3/8	DTRUE-14-4
1	1/2	0.41	1.45	1.22	1-1/2	7/8	1-5/16	DTRUE-16-8
1	3/4	0.62	1.45	1.36	1-1/2	1-1/8	1-3/8	DTRUE-16-12

Dimensions are for reference only and are subject to change

Union Tee (*Fractional* Tube)

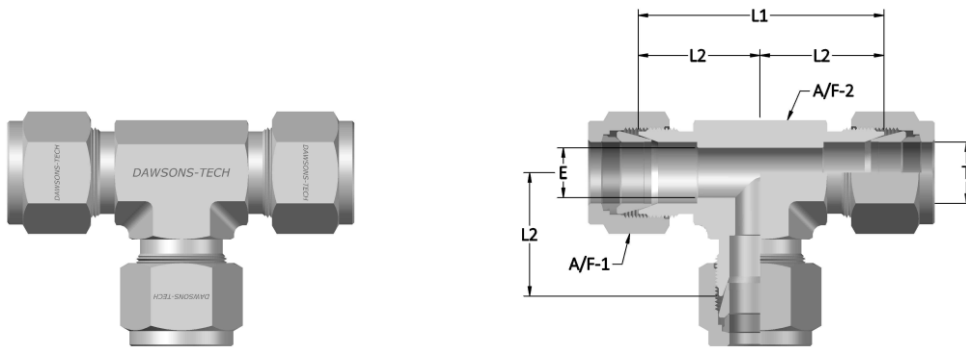

STANDARD CONFIGURATION DIMENSIONS

Tube OD	Dimension in Inch					Dawsons-Tech Part No.
	T	E	L1	L2	A/F1	
1/8	0.09	1.24	0.62	7/16	3/8	DTUT-2
3/16	0.12	1.40	0.70	1/2	7/16	DTUT-3
1/4	0.19	1.54	0.77	9/16	1/2	DTUT-4
5/16	0.25	1.76	0.88	5/8	5/8	DTUT-5
3/8	0.28	1.82	0.91	11/16	5/8	DTUT-6
1/2	0.41	2.04	1.02	7/8	13/16	DTUT-8
5/8	0.50	2.26	1.13	1	1	DTUT-10
3/4	0.62	2.34	1.17	1-1/8	1-1/16	DTUT-12
7/8	0.72	2.72	1.36	1-1/4	1-3/8	DTUT-14
1	0.88	2.90	1.45	1-1/2	1-3/8	DTUT-16

Dimensions are for reference only and are subject to change

Union Tee (*Metric* Tube)

Tube OD	Dimension in mm			A/F1	A/F2	Dawsons-Tech Part No.
	T	E	L1			
3	2.4	31.5	15.7	7/16	3/8	DTUT-3M
4	2.4	37.6	18.8	1/2	1/2	DTUT-4M
6	4.8	39.1	19.6	9/16	1/2	DTUT-6M
8	6.4	44.7	22.4	5/8	5/8	DTUT-8M
10	7.9	47.8	23.9	3/4	11/16	DTUT-10M
12	9.5	51.8	25.9	7/8	13/16	DTUT-12M
14	11.1	57.4	28.7	1	1	DTUT-14M
15	11.9	57.4	28.7	1	1	DTUT-15M
16	12.7	57.4	28.7	1	1	DTUT-16M
18	15.1	59.4	29.7	1-1/8	1-1/16	DTUT-18M
20	15.9	69.1	34.5	1-1/4	1-3/8	DTUT-20M
22	18.3	69.1	34.5	1-1/4	1-3/8	DTUT-22M
25	21.8	73.1	36.8	1-1/2	1-3/8	DTUT-25M

Dimensions are for reference only and are subject to change

Reducing Union Elbow (*Fractional* Tube)

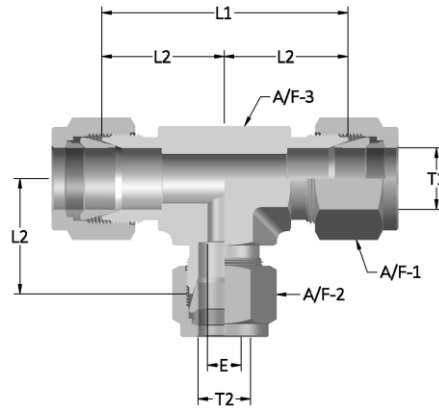
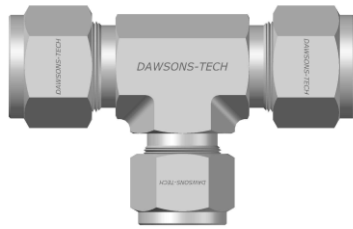

STANDARD CONFIGURATION DIMENSIONS

Tube OD	Reduced Tube OD	Dimension in Inch							Dawsons-Tech Part No.
T1	T2	E	L1	L2	L3	A/F1	A/F2	A/F3	
3/8	1/4	0.19	1.82	0.91	0.85	11/16	9/16	5/8	DTRUT-6-4
1/2	1/4	0.19	2.04	1.02	0.96	7/8	9/16	13/16	DTRUT-8-4
1/2	3/8	0.28	2.04	1.02	1.02	7/8	11/16	13/16	DTRUT-8-6
5/8	3/8	0.28	2.26	1.13	1.13	1	11/16	1	DTRUT-10-6
3/4	3/8	0.28	2.34	1.17	1.17	1-1/8	11/16	1-1/16	DTRUT-12-6
3/4	1/2	0.41	2.34	1.17	1.17	1-1/8	7/8	1-1/16	DTRUT-12-8
1	3/8	0.28	2.90	1.45	1.36	1-1/2	1-1/16	1-3/8	DTRUT-16-6
1	1/2	0.41	2.90	1.45	1.36	1-1/2	7/8	1-3/8	DTRUT-16-8
1	3/4	0.62	2.90	1.45	1.36	1-1/2	1-1/8	1-3/8	DTRUT-16-12

Dimensions are for reference only and are subject to change

Union Cross (*Fractional* Tube)

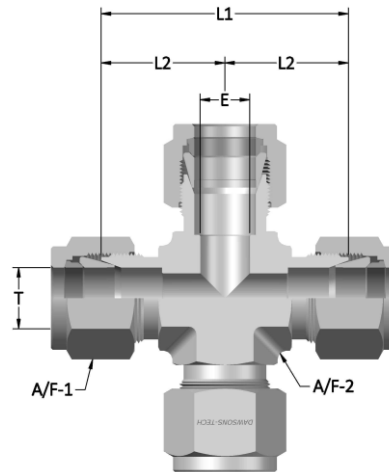
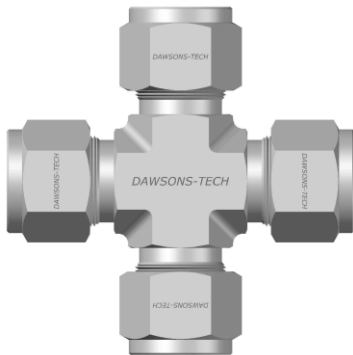

STANDARD CONFIGURATION DIMENSIONS

Tube OD	Dimension in Inch					Dawsons-Tech Part No.
T	E	L1	L2	A/F1	A/F2	
1/8	0.09	1.24	0.62	7/16	3/8	DTUC-2
1/4	0.19	1.54	0.77	9/16	1/2	DTUC-4
5/16	0.25	1.76	0.88	5/8	5/8	DTUC-5
3/8	0.28	1.82	0.91	11/16	5/8	DTUC-6
1/2	0.41	2.04	1.02	7/8	13/16	DTUC-8
3/4	0.62	2.34	1.17	1-1/8	1-1/16	DTUC-12
1	0.88	2.90	1.45	1-1/2	1-3/8	DTUC-16

Dimensions are for reference only and are subject to change

Union Cross (*Metric* Tube)

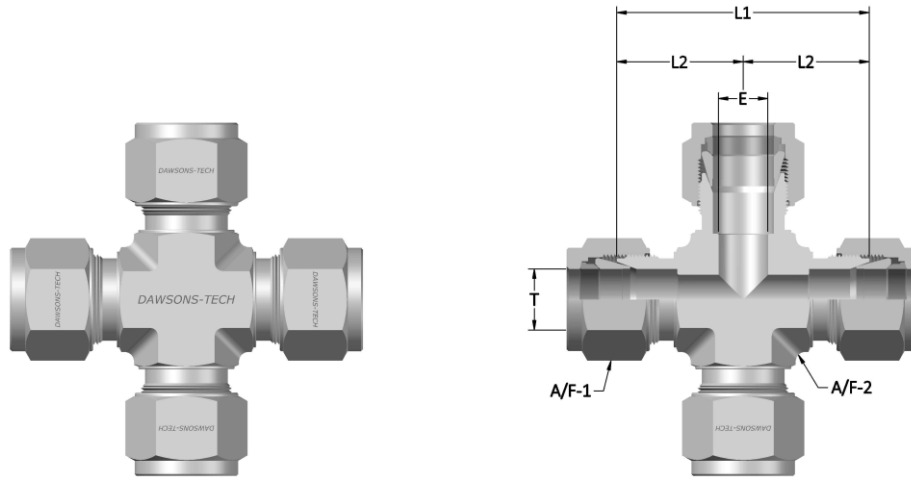

STANDARD CONFIGURATION DIMENSIONS

Tube OD	Dimension in mm			A/F1	A/F2	Dawsons-Tech Part No.
	T	E	L1			
3	2.4	31.5	15.7	7/16	3/8	DTUC-3M
6	4.8	39.1	19.6	9/16	1/2	DTUC-6M
8	6.4	44.7	22.4	5/8	5/8	DTUC-8M
10	7.9	47.8	23.9	3/4	11/16	DTUC-10M
12	9.5	51.8	25.9	7/8	13/16	DTUC-12M
16	12.7	53.8	26.9	1	15/16	DTUC-16M
18	15.1	56.4	28.2	1-1/8	1-1/16	DTUC-18M
20	15.9	69.0	34.5	1-1/4	1-3/8	DTUC-20M
25	21.8	73.6	36.8	1-1/2	1-3/8	DTUC-25M

Dimensions are for reference only and are subject to change

An Union (*Fractional* Tube to Flared Tube)

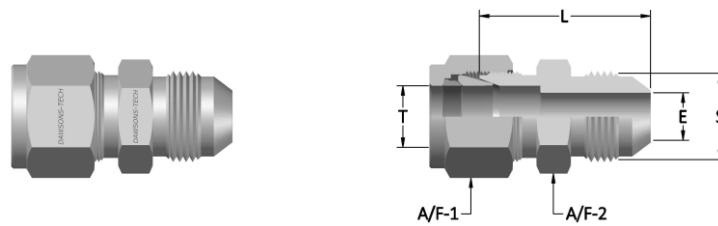

STANDARD CONFIGURATION DIMENSIONS

Tube OD	An Tube Flare	Dimension in Inch					Dawsons-Tech Part No.
		E	L	S	A/F1	A/F2	
1/8	1/8	0.06	1.01	5/16 - 24	7/16	7/16	DTAU-2-2AN
1/8	1/4	0.09	1.12	7/16 - 20	7/16	1/2	DTAU-2-4AN
1/4	1/4	0.17	1.19	7/16 - 20	9/16	1/2	DTAU-4-4AN
5/16	5/16	0.23	1.22	1/2 - 20	5/8	9/16	DTAU-5-5AN
3/8	1/4	0.17	1.27	7/16 - 20	11/16	5/8	DTAU-6-4AN
3/8	3/8	0.28	1.27	9/16 - 18	11/16	5/8	DTAU-6-6AN
1/2	1/2	0.39	1.41	3/4 - 16	7/8	13/16	DTAU-8-8AN
3/4	3/4	0.61	1.70	1-1/16 - 12	1-1/8	1-1/8	DTAU-12-12AN
1	1	0.84	1.94	1-5/16 - 12	1-1/2	1-3/8	DTAU-16-16AN

Dimensions are for reference only and are subject to change

An Bulkhead Union (*Fractional* Tube to Flared Tube)

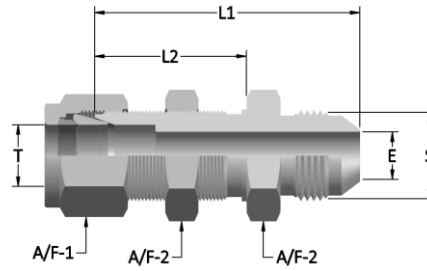
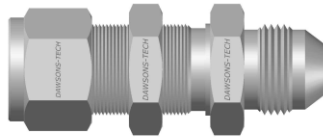

STANDARD CONFIGURATION DIMENSIONS

Tube OD T	An Tube Flare	Dimension in Inch						Panel Hole Size	Max. Panel Thickness	Dawsons-Tech Part No.
		E	L1	L2	S	A/F1	A/F2			
1/4	1/4	0.17	1.83	1.03	7/16 - 20	9/16	5/8	29/64	0.40	DTABU-4-4AN
3/8	3/8	0.28	1.96	1.16	9/16 - 18	11/16	3/4	37/64	0.44	DTABU-6-6AN
1/2	1/2	0.39	2.19	1.25	3/4 - 16	7/8	15/16	49/64	0.50	DTABU-8-8AN
3/4	3/4	0.61	2.71	1.57	1-1/16 - 12	1-1/8	1-3/16	1-1/64	0.66	DTABU-12-12AN
1	1	0.84	3.16	1.78	1-5/16 - 12	1-1/2	1-5/8	1-21/64	0.75	DTABU-16-16AN

Dimensions are for reference only and are subject to change

Tube Socket Weld Union (*Fractional* Tube)

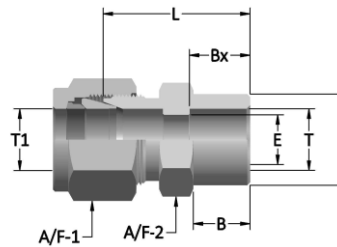
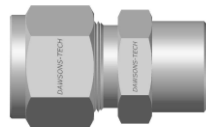

STANDARD CONFIGURATION DIMENSIONS

Tube OD T	Dimension in Inch							Dawsons-Tech Part No.
	B1	B2	E	J	L	A/F1	A/F2	
1/8	0.34	0.25	0.09	0.31	0.88	7/16	7/16	DTSWU-2
1/4	0.41	0.31	0.19	0.44	1.03	9/16	1/2	DTSWU-4
3/8	0.47	0.38	0.28	0.62	1.19	11/16	5/8	DTSWU-6
1/2	0.47	0.50	0.41	0.75	1.22	7/8	13/16	DTSWU-8
3/4	0.47	0.56	0.62	1.05	1.31	1-1/8	1-1/16	DTSWU-12
1	0.56	0.75	0.88	1.31	1.59	1-1/2	1-3/8	DTSWU-16

Dimensions are for reference only and are subject to change

Tube Socket Weld Elbow (*Fractional* Tube)

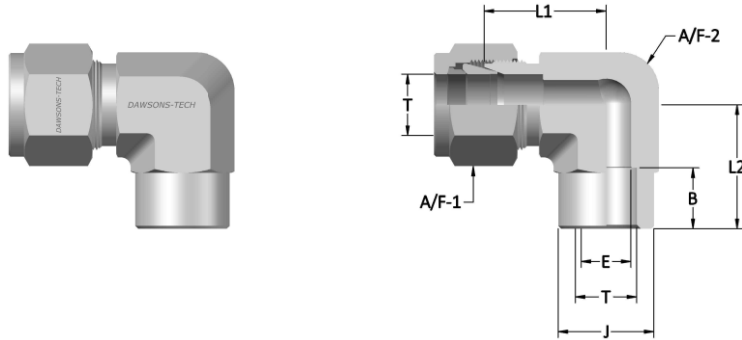

STANDARD CONFIGURATION DIMENSIONS

Tube OD	Dimension in Inch							Dawsons-Tech Part No.
T	B	E	J	L1	L2	A/F1	A/F2	
1/4	0.31	0.19	0.50	0.77	0.77	9/16	1/2	DTSWE-4
3/8	0.38	0.28	0.62	0.91	0.91	11/16	5/8	DTSWE-6
1/2	0.50	0.41	0.81	1.02	1.02	7/8	13/16	DTSWE-8
3/4	0.56	0.62	1.06	1.17	1.17	1-1/8	1-1/16	DTSWE-12
1	0.75	0.88	1.38	1.45	1.45	1-1/2	1-3/8	DTSWE-16

Dimensions are for reference only and are subject to change

Male Pipe Weld Connector (*Fractional* Tube to Male Pipe Weld)

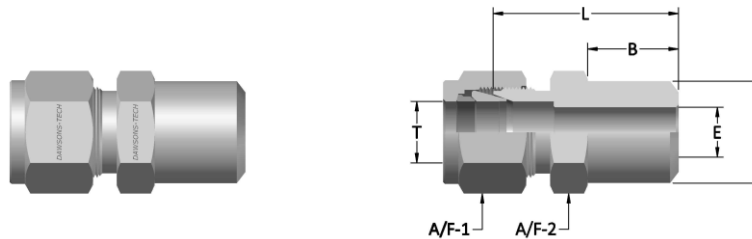

STANDARD CONFIGURATION DIMENSIONS

Tube OD	Male Pipe Weld	Dimension in Inch						Dawsons-Tech Part No.
T		B	E	J	L	A/F1	A/F2	
1/8	1/8	0.38	0.09	0.045	0.94	7/16	7/16	DTMWC-2-2
3/16	1/8	0.38	0.12	0.045	0.97	1/2	7/16	DTMWC-3-2
1/4	1/8	0.38	0.19	0.045	1.00	9/16	1/2	DTMWC-4-2
1/4	1/4	0.56	0.19	0.540	1.20	9/16	9/16	DTMWC-4-4
5/16	1/8	0.38	0.20	0.045	1.05	5/8	9/16	DTMWC-5-2
5/16	1/4	0.56	0.25	0.540	1.23	5/8	9/16	DTMWC-5-4
3/8	1/4	0.56	0.28	0.540	1.28	11/16	5/8	DTMWC-6-4
3/8	3/8	0.56	0.28	0.675	1.28	11/16	11/16	DTMWC-6-6
3/8	1/2	0.75	0.28	0.840	1.53	11/16	7/8	DTMWC-6-8
3/8	3/4	0.75	0.28	1.050	1.59	11/16	1-1/16	DTMWC-6-12
1/2	3/8	0.56	0.41	0.675	1.31	7/8	13/16	DTMWC-8-6
1/2	1/2	0.75	0.41	0.840	1.53	7/8	7/8	DTMWC-8-8
1/2	3/4	0.75	0.41	1.050	1.59	7/8	1-1/16	DTMWC-8-12
5/8	1/2	0.75	0.50	0.840	1.53	1	15/16	DTMWC-10-8
3/4	3/4	0.75	0.62	1.050	1.59	1-1/8	1-1/16	DTMWC-12-12
1	1	0.94	0.88	1.315	1.97	1-1/2	1-3/8	DTMWC-16-16

Dimensions are for reference only and are subject to change

Male Pipe Weld Connector (*Fractional* Tube to Male Pipe Weld)

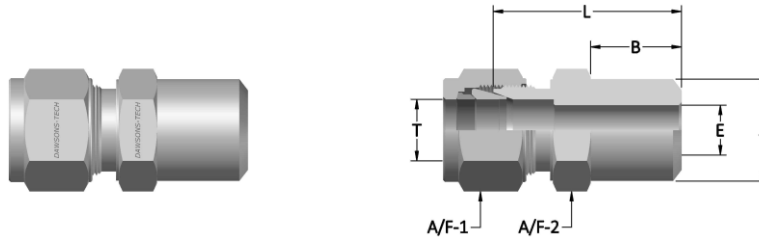

STANDARD CONFIGURATION DIMENSIONS

Tube OD T	Male Pipe Weld	Dimension in mm				A/F1	A/F2	Dawsons-Tech Part No.
		B	E	J	L			
3	1/8	9.7	2.4	10.3	23.9	7/16	7/16	DTMWC-3M-2
4	1/8	9.7	2.4	10.3	24.6	1/2	1/2	DTMWC-4M-2
6	1/8	9.7	4.8	10.3	25.4	9/16	9/16	DTMWC-6M-2
6	1/4	14.2	4.8	13.7	30.5	9/16	9/16	DTMWC-6M-4
8	1/8	9.7	5.1	10.3	26.7	5/8	5/8	DTMWC-8M-2
8	1/4	14.2	6.4	13.7	31.2	5/8	5/8	DTMWC-8M-4
8	1/2	19.0	6.4	21.3	38.1	5/8	7/8	DTMWC-8M-8
10	1/4	14.2	7.1	13.7	33.3	3/4	11/16	DTMWC-10M-4
10	3/8	14.2	7.9	17.1	33.3	3/4	11/16	DTMWC-10M-6
10	1/2	19.0	7.9	21.3	38.9	3/4	7/8	DTMWC-10M-8
12	1/4	14.2	7.1	13.7	33.3	7/8	7/8	DTMWC-12M-4
12	3/8	14.2	9.5	17.1	33.3	7/8	7/8	DTMWC-12M-6
12	1/2	19.0	9.5	21.3	38.9	7/8	7/8	DTMWC-12M-8
14	3/8	14.2	10.3	17.1	34.0	1	15/16	DTMWC-14M-6
15	1/2	19.0	11.9	21.3	38.9	1	15/16	DTMWC-15M-8
16	1/2	19.0	12.7	21.3	38.9	1	15/16	DTMWC-16M-8
18	1/2	19.0	13.5	21.3	40.4	1-1/8	1/1-16	DTMWC-18M-8

Dimensions are for reference only and are subject to change

Male Pipe Weld Elbow (*Fractional* Tube to Male Pipe Weld)

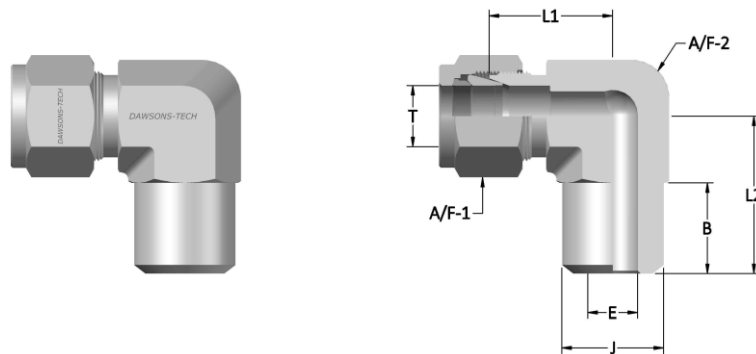

STANDARD CONFIGURATION DIMENSIONS

Tube OD T	Male Pipe Weld	Dimension in Inch							Dawsons-Tech Part No.
		B	E	J	L1	L2	A/F1	A/F2	
1/4	1/8	0.38	0.19	0.405	0.77	0.74	9/16	1/2	DTMWE-4-2
1/4	1/4	0.56	0.19	0.540	0.77	0.92	9/16	1/2	DTMWE-4-4
3/8	1/4	0.56	0.28	0.540	0.91	1.00	11/16	5/8	DTMWE-6-4
1/2	1/2	0.75	0.41	0.840	1.02	1.30	7/8	13/16	DTMWE-8-8
3/4	3/4	0.75	0.62	1.050	1.17	1.45	1-1/8	1-1/16	DTMWE-12-12

Dimensions are for reference only and are subject to change

Reducer (*Fractional* Tube to *Fractional* Ports)

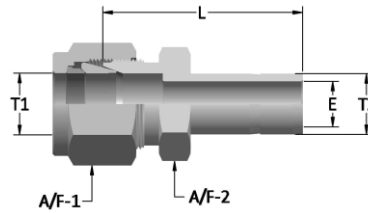
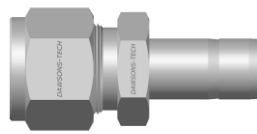

STANDARD CONFIGURATION DIMENSIONS

Tube OD	Tube OD	Dimension in Inch				Dawsons-Tech Part No.
T1	T2	E	L	A/F1	A/F2	
1/8	1/8	0.09	1.06	7/16	7/16	DTR-2-2
1/8	3/16	0.09	1.09	7/16	7/16	DTR-2-3
1/8	1/4	0.09	1.16	7/16	7/16	DTR-2-4
1/8	3/8	0.09	1.22	7/16	7/16	DTR-2-6
1/8	1/2	0.09	1.48	7/16	9/16	DTR-2-8
3/16	1/8	0.08	1.11	1/2	7/16	DTR-3-2
3/16	1/4	0.12	1.20	1/2	7/16	DTR-3-4
1/4	1/8	0.08	1.16	9/16	1/2	DTR-4-2
1/4	3/16	0.12	1.19	9/16	1/2	DTR-4-3
1/4	1/4	0.19	1.25	9/16	1/2	DTR-4-4
1/4	5/16	0.19	1.28	9/16	1/2	DTR-4-5
1/4	3/8	0.19	1.31	9/16	1/2	DTR-4-6
1/4	1/2	0.19	1.53	9/16	9/16	DTR-4-8
1/4	5/8	0.19	1.60	9/16	11/16	DTR-4-10
1/4	3/4	0.19	1.59	9/16	13/16	DTR-4-12
5/16	3/8	0.25	1.36	5/8	9/16	DTR-5-6
5/16	1/2	0.25	1.58	5/8	9/16	DTR-5-8
3/8	1/4	0.28	1.34	11/16	5/8	DTR-6-4
3/8	3/8	0.28	1.41	11/16	5/8	DTR-6-6
3/8	1/2	0.28	1.62	11/16	5/8	DTR-6-8
3/8	5/8	0.28	1.69	11/16	11/16	DTR-6-10
3/8	3/4	0.28	1.69	11/16	13/16	DTR-6-12
1/2	1/4	0.19	1.37	7/8	13/16	DTR-8-4
1/2	3/8	0.28	1.44	7/8	13/16	DTR-8-6
1/2	1/2	0.39	1.66	7/8	13/16	DTR-8-8
1/2	5/8	0.41	1.72	7/8	13/16	DTR-8-10
1/2	3/4	0.41	1.72	7/8	13/16	DTR-8-12
1/2	1	0.41	1.97	7/8	1-1/18	DTR-8-16
5/8	3/4	0.50	1.75	1	15/16	DTR-10-12
5/8	7/8	0.50	1.81	1	15/16	DTR-10-14
5/8	1	0.50	2.00	1	1-1/16	DTR-10-16
3/4	1/2	0.39	1.75	1-1/8	1-1/16	DTR-12-8
3/4	1	0.62	2.06	1-1/8	1-1/16	DTR-12-16

Dimensions are for reference only and are subject to change

Reducer (*Metric* Tube to *Metric* Ports)

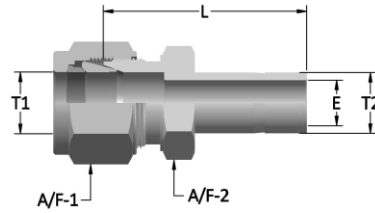
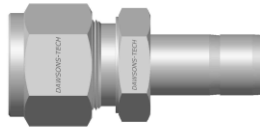

STANDARD CONFIGURATION DIMENSIONS

Tube OD	Tube OD	Dimension in mm		A/F1	A/F2	Dawsons-Tech Part No.
T1	T2	E	L			
3	4	2.4	28.4	7/16	7/16	DTR-3M-4M
3	6	2.4	29.5	7/16	7/16	DTR-3M-6M
3	10	2.4	31.8	7/16	1/2	DTR-3M-10M
4	6	2.4	30.5	1/2	7/16	DTR-4M-6M
6	3	1.8	39.5	9/16	1/2	DTR-6M-3M
6	8	4.8	32.5	9/16	1/2	DTR-6M-8M
6	10	4.8	33.3	9/16	1/2	DTR-6M-10M
6	12	4.8	38.9	9/16	9/16	DTR-6M-12M
6	18	4.8	42.2	9/16	13/16	DTR-6M-18M
8	6	4.6	32.8	5/8	9/16	DTR-8M-6M
8	10	6.4	34.5	5/8	9/16	DTR-8M-10M
8	18	6.4	40.1	5/8	3/4	DTR-8M-18M
10	6	4.6	34.8	3/4	11/16	DTR-10M-6M
10	8	6.4	35.8	3/4	11/16	DTR-10M-8M
10	12	7.9	42.4	3/4	11/16	DTR-10M-12M
10	15	7.9	43.7	3/4	11/16	DTR-10M-15M
10	18	7.9	43.7	3/4	13/16	DTR-10M-18M
12	6	4.6	34.8	7/8	13/16	DTR-12M-6M
12	8	6.4	35.8	7/8	13/16	DTR-12M-8M
12	10	7.7	36.6	7/8	13/16	DTR-12M-10M
12	16	9.5	43.7	7/8	13/16	DTR-12M-16M
12	18	9.5	43.7	7/8	13/16	DTR-12M-18M
12	20	9.5	46.0	7/8	7/8	DTR-12M-20M
12	22	9.5	46.0	7/8	15/16	DTR-12M-22M
12	25	9.5	52.3	7/8	1-1/16	DTR-12M-25M
16	12	9.1	42.9	1	15/16	DTR-16M-12M
18	12	9.1	44.5	1-1/8	1-1/16	DTR-18M-12M
18	16	12.7	46.0	1-1/8	1-1/16	DTR-18M-16M
18	20	15.1	47.5	1-1/8	1-1/16	DTR-18M-20M
18	22	15.1	47.5	1-1/8	1-1/16	DTR-18M-22M
18	25	15.1	52.3	1-1/8	1-1/16	DTR-18M-25M
20	16	12.7	47.8	1-1/4	1-3/16	DTR-20M-16M
20	18	13.9	47.8	1-1/4	1-3/16	DTR-20M-18M
20	22	15.8	49.3	1-1/4	1-3/16	DTR-20M-22M
20	25	15.8	54.1	1-1/4	1-3/16	DTR-20M-25M
22	18	13.9	47.8	1-1/4	1-3/16	DTR-22M-18M
22	20	15.1	49.3	1-1/4	1-3/16	DTR-22M-20M
22	25	18.3	54.1	1-1/4	1-3/16	DTR-22M-25M
25	18	13.9	50.8	1-1/2	1-3/8	DTR-25M-18M
25	20	15.1	52.3	1-1/2	1-3/8	DTR-25M-20M

Dimensions are for reference only and are subject to change

Reducer (*Metric* Tube to *Fractional* Ports)

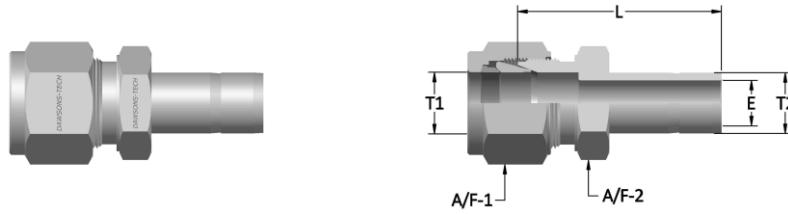

STANDARD CONFIGURATION DIMENSIONS

Tube OD	Tube OD	Dimension in mm		A/F1	A/F2	Dawsons-Tech Part No.
T1	T2	E	L			
3	1/8	2.0	26.9	7/16	7/16	DTR-3M-2
3	1/4	2.4	29.5	7/16	7/16	DTR-3M-4
4	1/4	2.4	30.5	1/2	7/16	DTR-4M-4
6	1/8	2.0	29.5	9/16	1/2	DTR-6M-2
6	1/4	4.9	31.8	9/16	1/2	DTR-6M-4
6	5/16	4.8	32.5	9/16	1/2	DTR-6M-5
6	3/8	4.8	33.3	9/16	1/2	DTR-6M-6
6	1/2	4.8	38.9	9/16	9/16	DTR-6M-8
8	3/8	6.4	34.5	5/8	9/16	DTR-8M-6
8	1/2	6.4	40.1	5/8	9/16	DTR-8M-8
10	3/8	7.1	36.6	3/4	11/16	DTR-10M-6
10	1/2	7.9	42.2	3/4	11/16	DTR-10M-8
12	1/2	9.5	42.2	7/8	13/16	DTR-12M-8
12	3/4	9.5	43.7	7/8	13/16	DTR-12M-12
18	3/4	15.1	46.0	1-1/8	1-1/16	DTR-18M-12
18	1	15.1	52.3	1-1/8	1-1/16	DTR-18M-16
25	1	20.2	57.2	1-1/2	1-3/8	DTR-25M-16

Dimensions are for reference only and are subject to change

Bulkhead Reducer (*Fractional* Tube to *Fractional* Ports)

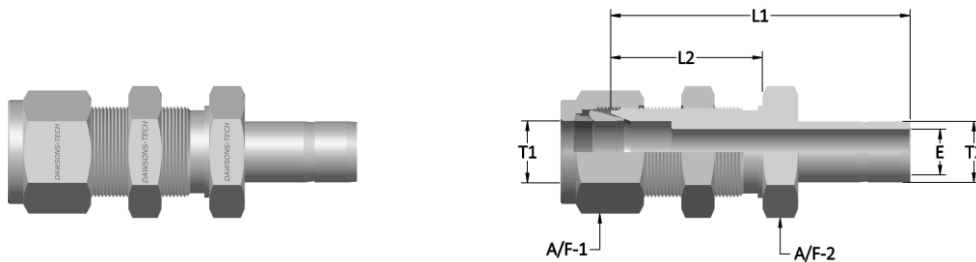

STANDARD CONFIGURATION DIMENSIONS

Tube OD	Dimension in Inch					Panel Hole Size	Max. Panel Thickness	Dawsons-Tech Part No.
T	E	L1	L2	A/F1	A/F2			
1/8	0.08	1.69	0.97	7/16	1/2	21/64	0.50	DTBR-2
1/4	0.19	1.91	1.03	9/16	5/8	29/64	0.40	DTBR-4
3/8	0.28	2.12	1.16	11/16	3/4	37/64	0.44	DTBR-6
1/2	0.39	2.47	1.25	7/8	15/16	49/64	0.50	DTBR-8
5/8	0.50	2.56	1.28	1	1-1/16	57/64	0.50	DTBR-10
1	0.80	3.47	1.78	1-1/2	1-5/8	1-21/64	0.75	DTBR-16

Dimensions are for reference only and are subject to change

Port Connector (*Fractional* Ports)

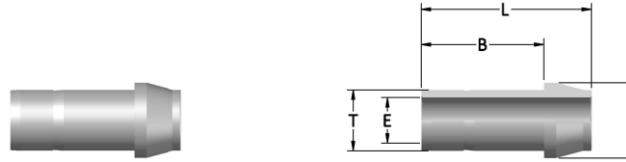

STANDARD CONFIGURATION DIMENSIONS

Tube OD	Dimension in Inch				Dawsons-Tech Part No.
T	B	E	J	L	
1/8	0.62	0.09	0.24	0.88	DTPC-2
1/4	0.74	0.19	0.37	0.97	DTPC-4
5/16	0.79	0.25	0.43	1.02	DTPC-5
3/8	0.80	0.30	0.50	1.03	DTPC-6
1/2	1.02	0.39	0.62	1.41	DTPC-8
3/4	1.09	0.59	0.87	1.47	DTPC-12
1	1.36	0.80	1.12	1.89	DTPC-16

Dimensions are for reference only and are subject to change

Port Connector (*Metric* Ports)

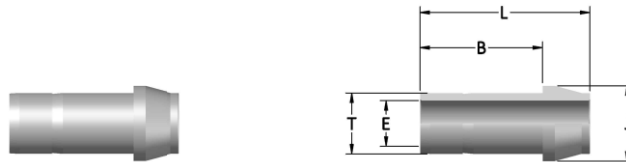

STANDARD CONFIGURATION DIMENSIONS

Tube OD	Dimension in mm				Dawsons-Tech Part No.
T	B	E	J	L	
3	15.7	2.1	6.0	22.2	DTPC-3M
6	18.7	4.4	9.0	24.6	DTPC-6M
8	20.0	6.2	11.0	25.9	DTPC-8M
10	20.2	8.2	13.1	26.1	DTPC-10M
12	26.0	9.1	15.0	35.8	DTPC-12M
15	27.6	12.7	19.0	37.4	DTPC-15M
16	27.6	12.7	19.0	37.4	DTPC-16M
18	27.6	13.9	21.0	37.4	DTPC-18M
20	29.2	15.1	23.0	38.9	DTPC-20M
25	34.5	19.8	28.0	48.0	DTPC-25M

Dimensions are for reference only and are subject to change

Reducing Port Connector (*Fractional* Ports)

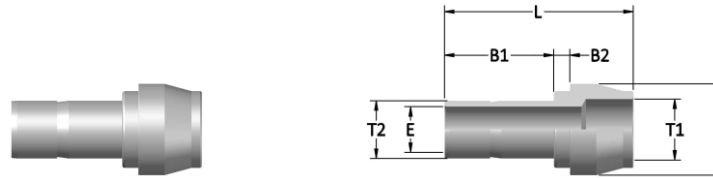

STANDARD CONFIGURATION DIMENSIONS

Tube OD	Reduced Tube OD	Dimension in Inch					Dawsons-Tech Part No.
T1	T2	B1	B2	E	J	L	
1/4	1/8	0.53	0.13	0.09	0.37	0.89	DTRPC-4-2
3/8	1/8	0.53	0.15	0.09	0.50	0.91	DTRPC-6-2
3/8	1/4	0.62	0.13	0.19	0.50	0.98	DTRPC-6-4
1/2	1/4	0.62	0.15	0.19	0.62	1.15	DTRPC-8-4
1/2	3/8	0.69	0.13	0.28	0.62	1.20	DTRPC-8-6
3/4	1/2	0.96	0.15	0.39	0.87	1.49	DTRPC-12-8
1	1/2	0.96	0.19	0.39	1.12	1.68	DTRPC-16-8
1	3/4	1.02	0.16	0.59	1.12	1.71	DTRPC-16-12

Dimensions are for reference only and are subject to change

Reducing Port Connector (*Metric* Ports)

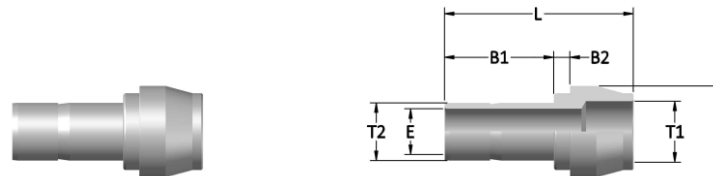

STANDARD CONFIGURATION DIMENSIONS

Tube OD	Reduced Tube OD	Dimension in mm					Dawsons-Tech Part No.
T1	T2	B1	B2	E	J	L	
6	3	13.5	3.2	2.2	9.0	22.6	DTRPC-6M-3M
8	6	15.7	3.1	4.6	11.0	24.7	DTRPC-8M-6M
10	6	15.7	3.4	4.6	13.1	25.0	DTRPC-10M-6M
10	8	17.0	3.1	6.4	13.1	26.0	DTRPC-10M-8M
12	6	15.7	3.6	4.6	15.0	29.1	DTRPC-12M-6M
12	8	16.8	3.4	6.4	15.0	29.8	DTRPC-12M-8M
12	10	17.5	3.1	7.7	15.0	30.4	DTRPC-12M-10M
16	12	23.1	3.4	9.1	19.0	26.2	DTRPC-16M-12M

Dimensions are for reference only and are subject to change

Cap (*Fractional* Tube)

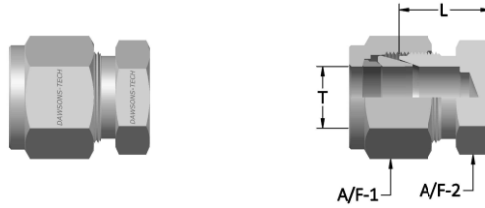

STANDARD CONFIGURATION DIMENSIONS

Tube OD T	Dimension in Inch			Dawsons-Tech Part No.
	L	A/F1	A/F2	
1/8	0.53	7/16	7/16	DTC-2
3/16	0.58	1/2	7/16	DTC-3
1/4	0.63	9/16	1/2	DTC-4
5/16	0.67	5/8	9/16	DTC-5
3/8	0.72	11/16	5/8	DTC-6
1/2	0.75	7/8	13/16	DTC-8
5/8	0.78	1	15/16	DTC-10
3/4	0.84	1-1/8	1-1/16	DTC-12
7/8	0.94	1-1/4	1-3/16	DTC-14
1	1.03	1-1/2	1-3/8	DTC-16

Dimensions are for reference only and are subject to change

Cap (*Metric* Tube)

Tube OD T	Dimension in mm L	A/F1	A/F2	Dawsons-Tech Part No.
4	14.7	1/2	1/2	DTC-4M
6	15.7	9/16	9/16	DTC-6M
8	17.0	5/8	5/8	DTC-8M
10	19.0	3/4	3/4	DTC-10M
12	19.0	7/8	7/8	DTC-12M
14	19.8	1	1	DTC-14M
15	19.8	1	1	DTC-15M
16	19.8	1	1	DTC-16M
18	21.3	1-1/8	1-1/8	DTC-18M
20	23.9	1-1/4	1-1/4	DTC-20M
22	23.9	1-1/4	1-1/4	DTC-22M
25	26.2	1-1/2	1-1/2	DTC-25M

Dimensions are for reference only and are subject to change

Plug (*Fractional* Tube)

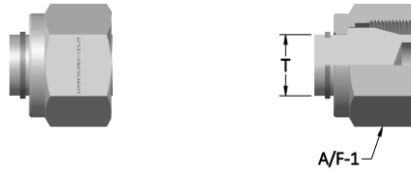

STANDARD CONFIGURATION DIMENSIONS

Tube OD	A/F	Dawsons-Tech Part No.
T		
1/8	7/16	DTP-2
3/16	1/2	DTP-3
1/4	9/16	DTP-4
5/16	5/8	DTP-5
3/8	11/16	DTP-6
1/2	7/8	DTP-8
5/8	1	DTP-10
3/4	1-1/8	DTP-12
7/8	1-1/4	DTP-14
1	1-1/2	DTP-16

Dimensions are for reference only and are subject to change

Plug (*Metric* Tube)

Tube OD	A/F	Dawsons-Tech Part No.
T		
3	7/16	DTP-3M
4	1/2	DTP-4M
6	9/16	DTP-6M
8	5/8	DTP-8M
10	3/4	DTP-10M
12	7/8	DTP-12M
14	1	DTP-14M
15	1	DTP-15M
16	1	DTP-16M
18	1-1/8	DTP-18M
20	1-1/4	DTP-20M
22	1-1/4	DTP-22M
25	1-1/2	DTP-25M

Dimensions are for reference only and are subject to change

Nut (*Fractional* Tube)

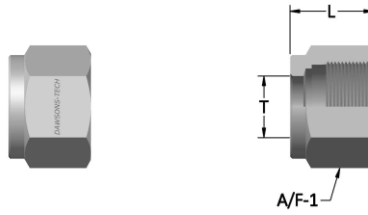

STANDARD CONFIGURATION DIMENSIONS

Tube OD	Dimension in Inch		Dawsons-Tech Part No.
	T	A/F	
1/8	0.47	7/16	DTN-2
3/16	0.47	1/2	DTN-3
1/4	0.50	9/16	DTN-4
5/16	0.53	5/8	DTN-5
3/8	0.56	11/16	DTN-6
1/2	0.69	7/8	DTN-8
5/8	0.69	1	DTN-10
3/4	0.69	1-1/8	DTN-12
7/8	0.69	1-1/4	DTN-14
1	0.81	1-1/2	DTN-16

Dimensions are for reference only and are subject to change

Nut (*Metric* Tube)

Tube OD	Dimension in mm		Dawsons-Tech Part No.
	T	A/F	
3	11.9	7/16	DTN-3M
4	11.9	1/2	DTN-4M
6	12.7	9/16	DTN-6M
8	13.5	5/8	DTN-8M
10	15.1	3/4	DTN-10M
12	17.4	7/8	DTN-12M
14	17.4	1	DTN-14M
15	17.4	1	DTN-15M
16	17.4	1	DTN-16M
18	17.4	1-1/8	DTN-18M
20	17.4	1-1/4	DTN-20M
22	17.4	1-1/4	DTN-22M
25	20.6	1-1/2	DTN-25M

Dimensions are for reference only and are subject to change

Front Ferrule

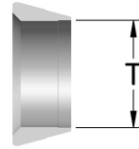

STANDARD CONFIGURATION DIMENSIONS

(Fractional Tube)

Tube OD (Inch)	Dawsons-Tech Part No.
T	
1/8	DTFF-2
3/16	DTFF-3
1/4	DTFF-4
5/16	DTFF-5
3/8	DTFF-6
1/2	DTFF-8
5/8	DTFF-10
3/4	DTFF-12
7/8	DTFF-14
1	DTFF-16

Dimensions are for reference only and are subject to change

(Metric Tube)

Tube OD (mm)	Dawsons-Tech Part No.
T	
3	DTFF-3M
4	DTFF-4M
6	DTFF-6M
8	DTFF-8M
10	DTFF-10M
12	DTFF-12M
14	DTFF-14M
15	DTFF-15M
16	DTFF-16M
18	DTFF-18M
20	DTFF-20M
22	DTFF-22M
25	DTFF-25M

Dimensions are for reference only and are subject to change

Back Ferrule

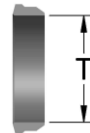

STANDARD CONFIGURATION DIMENSIONS

(Fractional Tube)

Tube OD (Inch)	Dawsons-Tech Part No.
T	
1/8	DTBF-2
3/16	DTBF-3
1/4	DTBF-4
5/16	DTBF-5
3/8	DTBF-6
1/2	DTBF-8
5/8	DTBF-10
3/4	DTBF-12
7/8	DTBF-14
1	DTBF-16

Dimensions are for reference only and are subject to change

(Metric Tube)

Tube OD (mm)	Dawsons-Tech Part No.
T	
3	DTBF-3M
4	DTBF-4M
6	DTBF-6M
8	DTBF-8M
10	DTBF-10M
12	DTBF-12M
14	DTBF-14M
15	DTBF-15M
16	DTBF-16M
18	DTBF-18M
20	DTBF-20M
22	DTBF-22M
25	DTBF-25M

Dimensions are for reference only and are subject to change

Bulkhead Lock Nut (*Fractional* Tube)

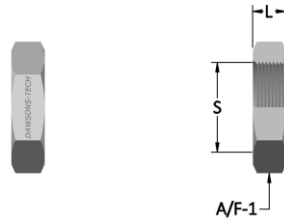

STANDARD CONFIGURATION DIMENSIONS

Tube OD	Dimension in Inch			Dawsons-Tech Part No.
T	L	S	A/F	
1/8	0.19	5/16 - 20	1/2	DTBLN-2
3/16	0.22	3/8 - 20	9/16	DTBLN-3
1/4	0.22	7/16 - 20	5/8	DTBLN-4
5/16	0.23	1/2 - 20	11/16	DTBLN-5
3/8	0.25	9/16 - 20	3/4	DTBLNC-6
1/2	0.28	3/4 - 20	15/16	DTBLN-8
5/8	0.32	7/8 - 20	1-1/16	DTBLN-10
3/4	0.34	1 - 20	1-3/16	DTBLN-12
7/8	0.38	1-1/8 - 20	1-3/8	DTBLN-14
1	0.38	1-5/16 - 20	1-5/8	DTBLN-16

Dimensions are for reference only and are subject to change

Bulkhead Lock Nut (*Metric* Tube)

Tube OD	Dimension in mm	S	A/F	Dawsons-Tech Part No.
T	L			
3	4.8	5/16 - 20	7/16	DTBLN-3M
4	5.6	3/8 - 20	1/2	DTBLN-4M
6	5.6	7/16 - 20	9/16	DTBLN-6M
8	5.6	1/2 - 20	5/8	DTBLN-8M
10	6.4	5/8 - 20	3/4	DTBLN-10M
12	7.1	3/4 - 20	7/8	DTBLN-12M
14	7.9	7/8 - 20	1	DTBLN-14M
15	7.9	7/8 - 20	1	DTBLN-15M
16	7.9	7/8 - 20	1	DTBLN-16M
18	8.6	1 - 20	1-1/8	DTBLN-18M
20	9.7	1-1/8 - 20	1-1/4	DTBLN-20M
25	9.7	1-5/16 - 20	1-1/2	DTBLN-25M

Dimensions are for reference only and are subject to change

Twin Ferrule Tube Fittings :

1. Ensure that, the end of the tube is cut square and free from burrs without causing undue chamfering of the tube end.
2. Loosen the Fitting Nut.
3. Insert the tubing into the Fitting assembly resting it firmly on the internal shoulder of the Fittings.
4. Finger tighten the Nut.
5. A) Tighten the nut with a wrench 1-1/4 turns from the finger tight position. For the tube Fittings size 6mm / 1/4" and above. (see fig 1)
 B) Tighten the nut with a wrench 3/4 turn from the finger tight position for the Tube Fittings size 4mm / 3/16" and below. (see fig 2)

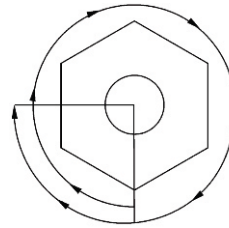

Figure : 1

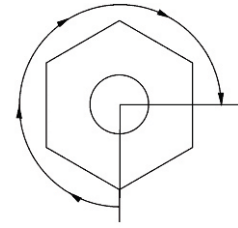

Figure : 2

DAWSONS-TECH Recommendation for high pressure application :

Due to variation in the tubing diameter DAWSONS-TECH recommends the following instructions for safety and excellent performance of high pressure applications.

1. After insertion of tubing to the Fittings assembly, tighten the nut approximately 1/8 turn with a wrench from finger tight position or until the tubing does not rotate freely by hand.
2. Further tighten the nut with a wrench 1-1/4 turns to have a firm and safe grip.

Reassembly Instruction :

DAWSONS-TECH Tube Fittings may be assembled and disassembled repeatedly. The following instructions should be carried out to reassemble the Fittings.

1. Firmly insert the tubing end with the previously set Ferrules into the Fitting body and tighten the Nut to a hand-tight condition.
2. With a wrench, tighten the Nut until a sharp condition rise in torque is felt, then simply snug with wrench.

SAE / MS Straight Thread and ISO Parallel Thread Positionable

Elbows and Tees Installation procedure :

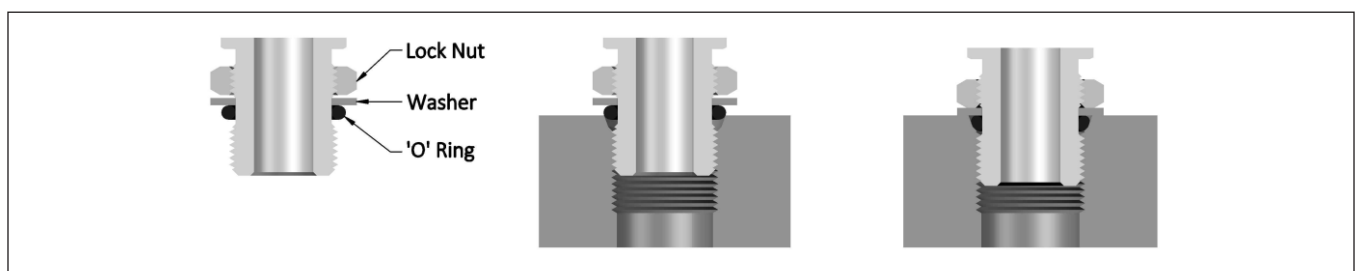

1. Lubricate the 'O' Ring with lubricant compatible with the system fluid and 'O' Ring material.
2. Turn the Fittings into the straight thread port until the metal back-up washer contacts the face of the port.
3. Position the Fittings by backing it out, (not more than one turn).
4. Hold the Fittings in position and tighten the Lock Nut until the washer contacts the face of the port.

Note :

1. SAE/MS Positionable Elbows and Tees are compatible with SAE J1926 ports.
2. ISO Parallel Thread Positionable Elbows and Tees are compatible with female ports having BS 2779 threads.

Installation Procedure :

The 'O' Ring requires a smooth, flat seating surface, this surface must be perpendicular to the axis of the threads.

1. Turn the 'O' Ring Seal Fitting in the port until finger tight.
2. The squeezing effect on the 'O' Ring can be felt during the last 1/4 turn.

SAE Specification :

DAWSONS-TECH SAE Straight thread 'O' Ring Fittings are designed and manufactured to meet SAE standard as follows

1. Male or External Fittings End (Dimension: SAE J514)
2. Straight thread SAE J475 (Equivalent to ANSI B1.1 or ISO R725)
3. Female or Internal Straight thread (Port : SAE J1926)

DAWSONS-TECH Tube Fittings with SAE Ends Straight thread

SAE Straight Thread 'O'-Ring Seal Fittings are designed and manufactured to SAE standards defined below for use in many different application including Hydraulics and Natural Gas Vehicles.

SAE Straight thread Fittings are supplied with Viton 'O' Rings.

Fittings Available Includes :

Connectors, Positionable SAE Elbows and Tees and SAE reducers.

Thread and 'O' Ring Sizes / Nominal Tube O.D.

Nominal Tube O.D. (Inch)	Port Size	Thread Size	'O' Ring Size No.
1/8	2	5/16 - 24	902
1/4	4	7/16 - 20	904
3/8	6	9/16 - 18	906
1/2	8	3/4 - 16	908
5/8	10	7/8 - 14	910
3/4	12	1-1/16 - 12	912
1	16	1-1/16 - 12	916

Port Connector Installation Procedure :

1. Remove Nut and Ferrules from the first of two Twin Ferrule Tube Fittings ports to be connected.
2. Slip Nut only on port Connector over machined Ferrule.
3. Insert Connector into first port and snug up Nut by hand. Tighten the Nut with wrench 1/4 turn only.
For 1/8, 3/16, 3mm and 4mm Tube Fittings, tighten the Nut 1/8 turn from finger tight position, subsequently connections are made snugging the Nut by hand.
4. Insert other end of port connector into Twin Ferrule Tube Fittings port 2, and tighten the Nut 1-1/4 turn.
For 1/8, 3/16, 3mm and 4mm Tube Fittings tighten the Nut 3/4 turn from finger tight position.

Plug Installation Procedure :

For 6mm, 1/4 and above size Tube Fittings, tighten the Plug with wrench 1/4 turn from finger tight position.

For 1/8, 3/16, 3mm and 4mm Tube Fittings, tighten the Plug with wrench 1/8 turn only.

Make subsequent connection by tightening slightly with wrench after snugging the Nut by

✳ **SWAGELOK®** is a registered trademark of Swagelok.



Fueling Products



Quick Connect Coupling



Tube Fittings for
Pressure Rating 15000 PSIG



Precision Thread Pipe Fittings
& Adapters



37° Flare Fittings



2 Way Ball Valves



3 Way Trunnion Ball Valves



Check Valves

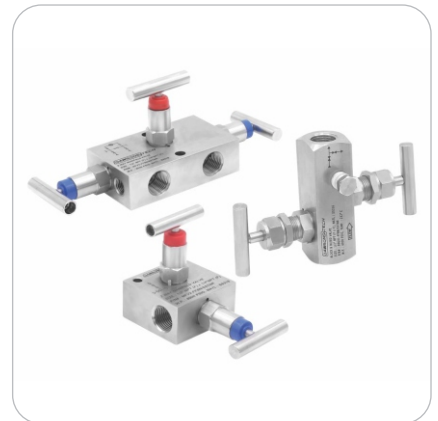

2 / 3 Way Manifold / Block & Bleed Valves



Relief Valves



CNG Receptacles
Series : DTLR01 & DTLR03





CNG Receptacles
Series : DTSR05 & DTSR07



Registered Office and Manufacturing Plant :

DAWSONS-TECH COMPONENTS LLP

 Unit No. DD - 6 & 7, Khan Real Industrial Estate,
N. H. 08, Pelhar, Vasai Phata, Vasai (East),
Dist. Palghar - 401 208, Maharashtra, India.
LLPIN: AAN-0434

 Mobile : +91-9833355596

 Email : info@dawsonstech.com

 Website: www.dawsonstech.com